

**TM 10-3930-626-12**

**DEPARTMENT OF THE ARMY TECHNICAL MANUAL**

---

**TECHNICAL MANUAL**

**OPERATOR AND ORGANIZATIONAL**

**MAINTENANCE MANUAL**

**TRACTOR, WHEELED, WAREHOUSE**

**GASOLINE, PNEUMATIC-TIRED**

**4,000 POUND DRAWBAR PULL**

**ARMY MODEL MHE -217**

**UNITED TRACTOR MODEL G40C**

**FSN 3930-181-3217**

---

**HEADQUARTERS, DEPARTMENT OF THE ARMY**

**JUNE 1971**

## W A R N I N G

Check the operating area to be sure it is clear of personnel and obstructions.

Do not allow smoking or the use of an open flame in the immediate vicinity while servicing the batteries. Batteries generate hydrogen, a highly explosive gas.

When filling the fuel tank, always provide a metal-to-metal contact between the container and the fuel tank. This will prevent a static spark from being generated as fuel flows over metallic surfaces. Do not fill fuel tank while the engine is running. Fuel spilled on a hot engine may explode and cause injury to personnel.

Exercise care at all times while handling electrolyte. When necessary to dilute electrolyte, always pour acid into water. Avoid breathing fumes and do not permit electrolyte to come in contact with skin. If electrolyte comes in contact with skin, wash affected area immediately with baking soda solution or with liberal quantity of water. If electrolyte splashes into eyes, wash immediately with liberal quantity of clean water and obtain medical aid as soon as possible.

Be alert for other workers to be sure they are not in the way of the moving tractor or towed load.

If the tractor is operated in an enclosed area, be sure adequate ventilation is provided. Exhaust gases contain carbon monoxide. Continued breathing of exhaust fumes is dangerous and can be fatal.

Use only approved cleaning solvents to prevent the possibility of fire or poisoning.

If the tractor is parked on an incline, block at least two wheels in the event of handbrake failure.

Radiator cleaning compound contains strong acid. Avoid contact with skin. If compound comes into contact with skin, wash affected area immediately with baking soda solution or with liberal quantity of water. If compound splashes into eyes, wash immediately with plenty of cold or warm water and obtain medical aid as quickly as possible.

## CHANGE

No. 4

HEADQUARTERS  
DEPARTMENT OF THE ARMY  
Washington D. C., 31 August 1991

Operator's and Organizational Maintenance Manual  
TRACTOR, WHEELED, WAREHOUSE, GASOLINE,  
PNEUMATIC-TIRES 4,000 POUND DRAWBAR  
PULL (ARMY MODEL MHE-217, UNITED TRACTOR  
MODEL G40C) NSN 3930-00-181-3217

TM 10-3930-626-12, 10 June 1971, is changed as follows:

*Inside Front Cover:* Add the following WARNING:

**WARNING**

When dislodging tire beads, locking, side ring flanges, or unbolting multi piece wheels, be absolutely certain no air pressure remains in the tire. Serious injury or loss of life could result.

**WARNING**

Always use an inflation safety cage to inflate tires mounted on multi piece rim and tire/rim assemblies not mounted on a tire changing machine that has a positive lockdown device designed to hold the assembly during inflation. When using a tire changing machine, always follow manufacturer's mounting and safety instructions. Failure to do so could cause serious injury or loss of life.

**WARNING**

Never inflate tires over 40 PSI to seat tire beads. Serious injury or loss of life could result.

**WARNING**

When inflating tires in a safety cage, always use an extension air hose and gage for safety cage use. Failure to do so could cause serious injury.

*Page 4-50, Paragraph 4-61.* "Front Tires"

(1). Add the following as sub-paragraph a. (2) and renumber the remaining sub-paragraphs; "(2) Deflate tire."

(2). Before sub-paragraph a. (2), after renumbering the sub-paragraph, add the following WARNING:

**WARNING**

Be sure tire is fully deflated before proceeding with next step. Failure to do so could result in injury or death.

(3). Delete "Deflate tire and" and capitalize "remove" in sub-paragraph a. (3).

(4). Add to sub-paragraph b. (3); "Reference TM 9-2610-200-24, CARE, MAINTENANCE, AND REPAIR OF PNEUMATIC TIRES AND INNER TUBES for additional information concerning tire maintenance."

(5). Add the following WARNING, prior to sub-paragraph c:

**WARNING**

Always use an inflation safety cage to inflate tires mounted on multi piece rims and tire/rim assemblies not mounted on a tire changing machine that has a positive lockdown device designed to hold the assembly during inflation. When using a tire changing machine, always follow

**manufacturer's mounting and safety instructions. Failure to do so could cause serious injury or loss of life.**

**WARNING**

**Never inflate tires over 40 PSI to seat tire bead. Serious injury or loss of life could result.**

**WARNING**

**When inflating tires in a safety cage, always use an extension air hose and gage for safety cage use. Failure to do so could cause serious injury.**

(6). Change sub-paragraph c. to read;

C. Installation. Using tire lubricant, assemble the tire and rim components. Inspect the wheel assembly to insure all components are properly installed. Place wheel assembly in safety cage and using an extension air hose and gage, inflate tire to a maximum of 15 PSI, and allow tube to center itself in the tire. Inflate tire not to exceed 40 PSI to seat both tire beads. Both tire beads should seat properly before reaching 40 PSI. If tire beads fail to seat, deflate tire, determine cause, take corrective action, add additional tire bead lubricant and inflate to recommended pressure.

Page 4-50, paragraph 4-62. "Drive wheel and Tires":

(1). After sub-Paragraph a.(2) add the following note :

**NOTE**

Removal may be easier if weight of wheel is supported by a wheeled floor jack or dolly

(2). After sub-paragraph a. (3) add the following WARNING:

**WARNING**

**Be sure tire is fully deflated before proceeding with next step. Failure to do so could result in injury or death.**

(3). Delete sub-paragraph b. (1) and renumber sub-paragraphs (2) and (3).

(4). Add the following to sub-paragraph b. (3): Reference TM 9-2610-200-24 CARE, MAINTENANCE, AND REPAIR OF PNEUMATIC TIRES AND INNER TUBES for additional information concerning tire maintenance.

(5). Add the following WARNINGS prior to sub-paragraph c:

**WARNING**

**Always use an inflation safety cage to inflate tires mounted on multi-piece rims and tire/rim assemblies not mounted on tires changing machine that has a positive lock down device designed to hold the assembly during inflation. . When using a tire changing machine, always follow manufacturer mounting and safety instruction. Failure to do so could cause serious injury or loss of life.**

**WARNING**

**Never inflate tires over 40 PSI to seat tire beads. serious injury or loss of life could result.**

**WARNING**

**When inflating tire in a safety cage, always use an extension air hose and gage for safety cage use. Failure to do so could cause serious injury.**

(6). Change sub-paragraph c. to read:

Using tire lubricant, assemble the tire and rim components, Inspect the wheel to insure all components are properly installed. Place wheel assembly in safety cage and using an extension air hose and gage, inflate tire to a maximum of 15 PSI, and allow tire to completely deflate. This will allow the tube to center itself in the tire. Inflate tire not to exceed 40 PSI to seat both tire beads. Both tire beads should seat properly before reaching 40 PSI. If tire beads fail to seat, deflate tire, determine

cause, take corrective action, add additional tire bead lubricant and inflate to recommended pressure. Concave mounting holes in one wheel must mate with convex mounting hole in second wheel.

#### **2-14.1 AIR CLEANER/AIR FILTER NBC WARNING DECAL**

A decal has been developed that warns of NBC exposure. It is to be positioned in a noticeable place on or near the air filter housing or air cleaner. You may order the decal using part number 12296626, CAGEC 19207. Refer to TB 43-0219 for further information.

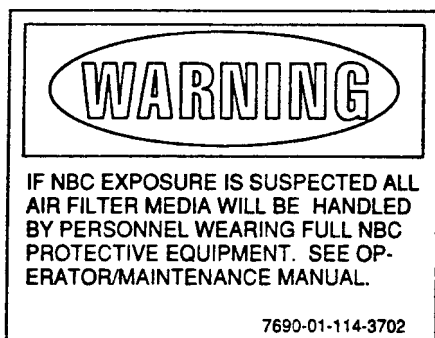

*Figure 2-2 NBC Warning Decal*

By Order of the Secretary of the Army:

GORDON R. SULLIVAN  
*General, United States Army*  
*Chief of Staff*

Official:

PATRICIA P. HICKERSON  
*Brigadier General, United States Army*  
*The Adjutant General*

Distribution:

To be distributed in accordance with DA Form 12-25-E (Block No. 2275) Unit maintenance requirements for TM10-3930-626-12.



CHANGE  
NO. 3

HEADQUARTERS  
DEPARTMENT OF THE ARMY  
Washington, D.C., 28 December 1989

**Operator's and Organizational Maintenance Manual**

**TRACTOR, WHEELED, WAREHOUSE, GASOLINE,  
PNEUMATIC-TIRED, 4,000 LB DRAWBAR PULL  
(ARMY MODEL MHE-217)  
(UNITED TRACTOR MODEL G40C)  
NSN 3930-00-181-3217**

TM 10-3930-626-12, 10 June 1971, is changed as follows:

*Cover and page i.* The manual title is changed to read as shown above.

*Page iii,* List of Illustrations. Delete entry for number "4-7".

*Page 1-1.*

Paragraph 1-1. Change "Federal Stock Number 3930-181-3217" to "NSN 3930-00-181-3217".

Paragraph 1-2 is superseded as follows:

**1-2. Maintenance Forms, Records, and Reports**

Maintenance forms, records, and reports which are to be used by maintenance personnel at all maintenance levels are listed in and prescribed by DA Pam 738-750.

Paragraph 1-3 is superseded as follows:

**1-3. Reporting Errors and Recommending Improvements**

You can help improve this manual. If you find any mistakes or if you know of a way to improve the procedures, please let us know. Mail your letter or DA Form 2028 (Recommended Changes to Publications and Blank Forms) direct to: Commander, U.S. Army Tank-Automotive Command, AMSTA-MB, Warren, MI 48397-5000. A reply will be furnished to you.

*Page 1-2.* Pages 1-2 and I-2 were inadvertently printed in reverse.

*Page 1-3,* paragraph 1-5b(1). After *steering gear*, add:

\*Steering gear housing ..... ¾ pt

*Page 1-4.*

Paragraph 1-5b(4), item 1. Change the number of tires from "6" to "4".

Paragraph 1-5b(5).

Item 11. Change the governor speed from "3450" to "2400".

Item 13. After the present entry, add "1-5-3-6-2-4".

Item 38. Change the governor speed from "2450" to "2400".

*Page 2-4.*

Change subparagraph "2-8a" to "2-8b" and subparagraph "2-8b" to "2-8a".

Paragraph 2-9b, line 8. Change "left" to "right".

*Page 2-6.* Paragraph 2-13d is superseded as follows:

*d.* Turn the ignition switch lever to the OFF position to stop the engine.

*Page 2-7,* paragraph 2-24. Change "TB 5-4200-200-10" to "TB 5-4200-200-100".

*Page 3-2.* Paragraph 3-3e is superseded as follows:

*e. Checking Transmission and Torque Converter Oil Level.*

**Caution:** Prior to starting tractor or performing check, apply parking brake and place transmission

\* This change supersedes C 1, 5 January 1973.

selector in park position. Transmission without a park gear: apply parking brake and place shift lever in neutral.

(1) Set transmission shift lever to P (park) if applicable or N (neutral) position.

(2) Start engine and allow engine to run at idle speed with transmission shift lever in P (park), if applicable, or N (neutral) for at least four minutes.

(3) Apply service brake, and shift transmission shift lever through all positions two or three times. Return shift lever to "P" or "N" position and release

service brake.

(4) With engine still idling, pull out the transmission oil gage and wipe with a clean cloth.

(5) Reinsert oil level indicator gage firmly.

(6) Pull out oil level indicator gage and read oil level.

(7) If the oil level is below the Full mark, add oil (in accordance with LO) by pouring through oil level indicator tube. Add just enough oil to bring the level up to the Full mark.

Page 3-3. Table 3-1 is superseded as follows:

Operator's Maintenance Category			Daily Schedule (or weekly)		
Interval and sequence number			Item to be inspected	Procedure	Paragraph reference
Before operation	During operation	After operation			
1			Radiator	Remove radiator cap and check coolant level; add coolant if required.	Para 3-11b
2			Engine crankcase	Check oil level; add oil if required.	Para 3-3d
*3			Air cleaner	Clean.	Para 3-12
4			Battery	Check electrolyte level; add water if required.	Para 3-15
5			Battery cables	Check that battery clamps are tight and that cables are in good condition. If cables are damaged or deteriorated, notify organizational maintenance.	
6			Transmission	Check oil level; add oil if required.	Para 3-3e
*7			Tires and tubes	Inspect tires for cuts, excessive wear and embedded foreign objects. Check inflation pressure; increase or decrease pressure if required. Report all problems to organizational maintenance	Para 3-14
8		1	Fuel tank	Add fuel as required.	Para 3-13
9			Fire extinguisher	Inspect for broken seal.	Para 2-22
	1		Instruments	Check that all instruments indicate within the required range.	Para 2-12e
	2		Controls	Check that controls perform as required.	Para 2-8
10	3	2	Fuel tank tube assembly	Check for leaks or damage. Report leaks or damage to organizational maintenance.	
11			Fan belt	Inspect for worn, frayed, or cracked condition. Check for proper tension (1/2 inch deflection midway between generator pulley and fan pulley). If fan belt requires adjustment or replacement, notify organizational maintenance.	
12			Water pump	Inspect for leakage at shaft seal and at gasket where pump mounts to engine block. Report any leaks to organizational maintenance.	
13			Horn	Ensure horn works. If horn does not work, notify organizational maintenance.	

\* To be accomplished weekly instead of daily.

Page 3-4. Paragraph 3-10 is superseded as follows:

**3-10. Transmission**

Check oil level in transmission daily (more often under severe operating conditions). Refer to paragraph 3-3e.

Page 4-1.

Paragraph 4-9, line 9. Add "Refer to LO 10-3930-626-12" between "grease" and "and".

Paragraph 4-10. Add a comma after "Link" in title and delete "and".



Add paragraph 4-11.1 as follows:

#### 4-11.1. Transmission

Check transmission and torque converter oil level as described in subparagraph 3-3e. If oil level is below the FULL mark, add oil by pouring through the oil level indicator tube. Add just enough oil to bring the level up to the FULL mark. Refer to LO 10-3930-626-12.

Page 4-2, Table 4-1, sequence numbers 7 and 8. Procedures column is changed to read "Remove, clean, and replace if necessary."

Page 4-6, paragraph 4-22b(1), line 2. Delete "start engine."

Page 4-7.

Paragraph 4-22b(8), line 3. Change "remove" to "remote".

Paragraph 4-23b(1), line 2. Delete "or number six".

Page 4-10. Paragraph 4-25 is rescinded.

Page 4-11. Figure 4-7 is rescinded.

Page 4-13. Paragraph 4-28 is rescinded.

Page 4-15. Paragraph 4-30.1 is added as follows:

#### 4-30.1. Water Pump, Fan, and Fan Belt

##### a. Removal.

(1) Open the drain cocks in the engine block, lower the right corner of the radiator, and allow the coolant to drain. If the coolant is clean, allow it to drain into a clean container and save it for reuse.

(2) Loosen the screw securing the adjusting arm to the generator (fig. 4-10). Push the generator toward the engine block to slacken the fan belt. Remove the fan belt from the fan and water pump pulley.

(3) Remove the four screws and lockwashers which secure the fan and pulley (fig. 4-11) to the water pump. Remove the fan, fan spacer, and pulley.

(4) Loosen the hose clamps on the bypass hose, and remove the hose from the water pump.

(5) Loosen the hose clamp on the lower radiator hose, and remove the hose from the water pump.

(6) Remove the 3 screws and lockwashers which secure the water pump to the engine block. Withdraw the water pump and gasket (fig. 4-11). Discard the gasket.

##### b. Inspection.

(1) Inspect the water pump for secure mounting.

(2) Inspect the water pump bearings for noise.

(3) Inspect the water pump for evidence of coolant leakage.

(4) Inspect the fan for secure mounting and bent or cracked blades.

(5) Inspect the fan belt for wear, fraying, and proper adjustment of 1/2 inch finger pressure deflection at midpoint between the generator pulley and fan pulley. Replace the belt if it is frayed, cracked, or deteriorated in any way.

c. *Installation.* Reverse the procedure in subparagraph a using a new water pump mounting gasket.

##### d. Adjustment of Belt.

(1) Loosen the screw securing the adjusting arm to the generator (fig. 4-10) and loosen the generator mounting screws.

(2) Pivot the generator for the desired belt tension (subparagraph b), and tighten the adjusting arm screw and generator mounting screw.

*Note.* All references to paragraph 4-28 in the base manual are reflected in paragraph 4-30.1.

Page 4-20, paragraph 4-37b(3)(b). Line 1 is changed as follows: "Low pressure or volume indicates a . . ."

Page 4-21. Paragraph 4-38a(1) is changed as follows:

(1) Hoist and securely block the tractor to obtain access to the fuel tank.

Page 4-25, paragraph 4-42b. Add step (3) as follows:

(3) Replace all defective parts.

Page 4-26, paragraph 4-44b(3). Change line 1 to read: "Raise and securely block rear . . . working."

Page 4-29.

After paragraph 4-46b(1), add:

**Caution: Disconnect ground cable before removing or replacing electrical components.**

Paragraph 4-46c(2), line 1. Change "Repolarize" to "Polarize".

Page 4-38.

Paragraph 4-48a is superseded as follows:

a. *Testing.* Make the following tests to isolate malfunctions:

(1) *Testing starter resistance and current drain.*

(a) Test the vehicle battery electrolyte specific gravity. The specific gravity should be 1.220 or above. If the specific gravity is below 1.220, recharge the battery to a full charge before proceeding with the test.

(b) Disconnect the positive battery lead from the battery terminal post. Connect a 0- to 300-ampere ammeter between the disconnected lead and the battery terminal post.

(c) Connect a voltmeter between the battery positive post and the starter switch terminal at the starter solenoid.

(d) Crank the engine and observe the readings on the voltmeter and ammeter. Voltage should not exceed 0.3 volt. A reading that exceeds 0.3 volt indicates that there is high resistance caused from loose circuit connections, a faulty cable, a burned starter relay, or the solenoid switch contacts are bad. A current that is high and is combined with a slow cranking speed, indicates that the starter should be removed and repaired.

(2) *Starter ground circuit test.*

(a) Connect the voltmeter positive lead to the starter housing and the negative lead to the battery negative post.

(b) Crank the engine with a remote control starter switch and observe the voltmeter reading. The voltmeter reading should not exceed 0.2 volt. If the voltmeter reading is greater than 0.2 volt, it indicates excessive voltage loss in the starter ground circuit. To isolate the point of excessive voltage loss, repeat the test at the starter drive housing, the cable terminal at the engine, and the cable clamp at the battery.

(c) A small change will occur each time a portion of the circuit is removed from the test. A definite change in the voltmeter reading indicates that the last part eliminated in the test is faulty. Maximum allowable voltage loss is 0.2 volt for the battery ground cable, 0.1 volt for the engine ground circuit, and 0.0 at each connection.

Paragraph 4-48b(2) is changed to read as follows:

(2) Securely block vehicle to a suitable working height.

After the title of paragraph 4-49, add:

*Note.* It is not necessary to remove the distributor in order to inspect, repair, or adjust it.

Page 4-39. In NOTE after paragraph 4-49c(2), delete the words "believed to be".

Page 4-42.

Add paragraph 4-51b.1 as follows:

*b.1 Repair.* Refer to TM 9-6140-200-14 for battery repair.

Add paragraph 4-51.1 as follows:

#### 4-51.1. Horn Button Assembly

*a. Removal.*

(1) Remove battery compartment floor plate.

(2) Disconnect horn cable from connector at lower end of steering gear housing.

(3) Pull out horn button cover. Remove three screws securing horn button assembly to steering wheel and remove horn button assembly.

*b. Inspection and Repair.*

(1) Inspect all parts for cracks, corrosion, and other damage. Replace all damaged parts.

(2) Inspect horn cable for brittle insulation. Replace cable if insulation is brittle or cracked.

*c. Installation.*

(1) Slide horn button lead down center of steering column and secure to connector at lower end of steering gear housing.

(2) Secure horn button assembly to steering wheel with three screws.

(3) Snap horn button cover in place in steering wheel.

After paragraph 4-53a(3), add the following:

**Caution:** Care should be exercised that the rollers are not accidentally dropped from the trunnion bearings.

Page 4-44, paragraph 4-55a(2)(f), line 1. Change "4-35" to "4-36".

Page 4-45, paragraph 4-55b(2)(a). Add "and securely block." to the end of the sentence.

Page 4-46.

Paragraph 4-56a(1). Add "and securely block." to the end of the sentence.

Paragraph 4-56b(1). Change "4-60a" to "4-62a".

After paragraph 4-56b(4). Add paragraph *b.1* as follows:

*b.1. Cleaning.* Clean all metal parts with approved cleaning solvent.

*Note.* Do not clean brake shoe linings or rubber parts with cleaning solvent; it will cause them to deteriorate.

Page 4-48. Paragraph 4-58 is superseded as follows:

#### 4-58. Service Brake Pedal and Linkage

*a. Removal.*

(1) Unscrew brake pedal pad (31, fig. 4-39) from brake pedal (29) and remove lock washer (30).

(2) Remove vehicle front floor plate.

(3) Disconnect return spring (28) from brake pedal (29).

(4) Disconnect master cylinder push rod from brake pedal (29) by removing nut (32), bolt (25), and sleeve bearing (26).

(5) Remove nut (22), lock washer (21), and cap screw (24), then gently drive brake pedal shaft (23) out of supporting brackets.

(6) Withdraw brake pedal (29) from vehicle. Remove sleeve bearings (33) and lubrication fitting (27) from brake pedal (29) only if replacement of these parts is required.

*b. Cleaning, Inspection, Repair and Replacement.*  
No specific procedures are required for the cleaning, inspection, repair or replacement of removed and disassembled brake pedal and linkage parts. Clean and dry all parts thoroughly, and inspect for cracks, deformity, and other damage. Replace all damaged parts.

*c. Installation.*

(1) Install lubrication fitting (27) and sleeve bearings (33) in brake pedal (29) if removed.

(2) Carefully position brake pedal (29) in vehicle and secure in place by gently driving brake pedal shaft (23) through brackets in vehicle. Secure brake pedal shaft (23) with cap screw (24), lock washer (21), and nut (22).

(3) Reconnect master cylinder push rod to brake pedal with bolt (25), sleeve bearing (26), and nut (32).

(4) Reconnect return spring (28) to brake pedal (29).

(5) Screw brake pedal pad (31) onto brake pedal (29) using lock washer (30).

(6) Adjust linkage (para 4-58d).

(7) Lubricate brake pedal shaft (LO 10-3930-626-12).

(8) Install vehicle front plate.

*d. Brake Pedal Adjustment.*

(1) Unscrew brake pedal pad (31) from brake pedal (29).

(2) Remove accelerator pedal from front floor plate (para 4-40a).

(3) Remove front floor plate.

(4) Remove pedal return spring (28) to more easily feel range of free pedal.

(5) Loosen nut (32) and turn eccentric bolt (25) until 3/8 to 5/8 inch free travel is obtained at pedal pad end of brake pedal.

(6) Lock eccentric bolt (25) in place with nut (32).

(7) Install front floor plate.

(8) Reinstall accelerator pedal and brake pedal pad.

*Page 4-51.* Paragraph 4-65a (1) is superseded as follows:

(1) Raise vehicle to a suitable working height and securely block it.

*Page 4-53.*

Paragraph 4-65d. Immediately after heading, add "Lubricate drag link with grease. Refer to LO 10-3930-626-12."

Paragraph 4-65e, last sentence. Add "new" between "insert" and "cotter".

Paragraph 4-66a(1) is superseded as follows:

(1) Raise vehicle to a suitable working height and securely block it.

Paragraph 4-66d. Immediately after heading add: "Lubricate tie rod with grease. Refer to LO 10-3930-626-12".

*Page A-1.*

Paragraph A-1. Change "TB 5-4200-200-10" to "TB 5-4200-200-100".

Paragraph A-3. Change "TM 9-213" to "TM 43-0139".

Paragraph A-5.

Change "TM 38-750" to "DA Pam 738-750".

Change the title of TM 10-3930-626-20P to "Unit Repair Parts and Special Tools Lists, Tractor, Wheeled, Warehouse, Gasoline, Pneumatic-Tired, 4,000 LB Drawbar Pull (Army Model MHE-217), (United Tractor Model G40C) NSN 3930-00-181-3217".

Change "TM 9-6140-200-15" and its title to "TM 9-6140-200-14, Operator's, Organizational, Direct Support and General Support Maintenance Manual for Lead-Acid Storage Batteries".

Paragraph A-7. Change "TM 750-244-3" and its title to "TM 750-244-6, Procedures for Destruction of Tank-Automotive Equipment to Prevent Enemy Use".

## APPENDIX B MAINTENANCE ALLOCATION CHART

---

### Section I. INTRODUCTION

#### B-1. General

a. This section provides a general explanation of all maintenance and repair functions authorized at the various maintenance levels.

b. The Maintenance Allocation Chart (MAC) in Section II designates overall authority and responsibility for the performance of maintenance functions on the identified end item or component. The application of the maintenance functions to the end item or component will be consistent with the capacities and capabilities of the designated maintenance levels.

c. Section III lists the tools and test equipment (both special tools and common tool sets) required for each maintenance function as referenced from Section II.

d. Section IV contains supplemental instructions and explanatory notes for a particular maintenance function.

#### B-2. Maintenance Functions

Maintenance functions will be limited to and defined as follows:

a. *Inspect.* To determine the serviceability of an item by comparing its physical, mechanical, and/or electrical characteristics with established standards through examination (e.g., by sight, sound, or feel).

b. *Test.* To verify serviceability by measuring the mechanical, pneumatic, hydraulic, or electrical characteristics of an item and comparing those characteristics with prescribed standards.

c. *Service.* Operations required periodically to keep an item in proper operating condition, i.e., to clean (includes decontaminate, when required), to preserve, to drain, to paint, or to replenish fuel, lubricants, chemical fluids, or gases.

d. *Adjust.* To maintain or regulate, within prescribed limits, by bringing into proper or exact position, or by setting the operating characteristics to specified parameters.

e. *Aline.* To adjust specified variable elements of an item to bring about optimum or desired performance.

f. *Calibrate.* To determine and cause corrections to be made or to be adjusted on instruments or test, measuring, and diagnostic equipments used in precision measurement. Consists of comparisons of two instruments, one of which is a certified standard of known accuracy, to detect and adjust any discrepancy in the accuracy of the instrument being compared.

g. *Remove/Install.* To remove and install the same item when required to perform service or other maintenance functions. Install may be the act of emplacing, seating, or fixing into position a spare, repair part, or module (component or assembly) in a manner to allow the proper functioning of an equipment or system.

h. *Replace.* To remove an unserviceable item and install a serviceable counterpart in its place. "Replace" is authorized by the MAC and is shown as the third position of the SMR code.

i. *Repair.* The application of maintenance services, including fault location/troubleshooting, removal/installation, and disassembly/assembly procedures, and maintenance actions to identify troubles and restore serviceability to an item by correcting specific damage, fault, malfunction, or failure in a part, subassembly, module (component or assembly), end item, or system.

j. *Overhaul.* That maintenance effort (service/action) prescribed to restore an item to a completely serviceable/operational condition as required by maintenance standards in appropriate technical publications (i.e., DMWR). Overhaul is normally the highest degree of maintenance performed by the Army. Overhaul does not normally return an item to like new condition.

k. *Rebuild.* Consists of those services/actions necessary for the restoration of unserviceable equipment to a like new condition in accordance with original manufacturing standards. Rebuild is the highest degree of materiel maintenance applied to Army equipment. The rebuild operation includes the act of returning to zero those age measurements (hours/miles, etc.) considered in classifying Army equipment/components.

**B-3. Explanation of Columns in the MAC, Section II**

a. *Column 1, Group Number.* Column 1 lists functional group code numbers, the purpose of which is to identify maintenance significant components, assemblies, subassemblies, and modules with the next higher assembly. End item group number shall be "00."

b. *Column 2, Component/Assembly.* Column 2 contains the names of components, assemblies, subassemblies, and modules for which maintenance is authorized.

c. *Column 3, Maintenance Function.* Column 3 lists the functions to be performed on the item listed in Column 2. (For a detailed explanation of these functions, see paragraph B-2.)

d. *Column 4, Maintenance Level.* Column 4 specifies, by the listing of a *work time* figure in the appropriate subcolumn(s), the level of maintenance authorized to perform the function listed in Column 3. This figure represents the active time required to perform that maintenance function at the indicated level of maintenance. If the number or complexity of the tasks within the listed maintenance function vary at different maintenance levels, appropriate work time figures will be shown for each level. The work time figure represents the average time required to restore an item (assembly, subassembly, component, module, end item, or system) to a serviceable condition under typical field operating conditions. This time includes preparation time (including any necessary disassembly/assembly time), troubleshooting/ fault location

time, and quality assurance/quality control time in addition to the time required to perform the specific tasks identified for the maintenance functions authorized in the Maintenance Allocation Chart. The symbol designations for the various maintenance levels are as follows:

- C ..... Operator or Crew
- O ..... Organizational Maintenance
- F ..... Direct Support Maintenance
- H ..... General Support Maintenance
- D ..... Depot Maintenance

e. *Column 5, Tools and Equipment.* Column 5 specifies, by code, those common tool sets (not individual tools) and special tools, TMDE, and support equipment required to perform the designated function.

f. *Column 6, Remarks.* This column shall, when applicable, contain a letter code, in alphabetic order, which shall be keyed to the remarks contained in Section IV.

**B-4. Explanation of Columns in Tool and Test Equipment Requirements, Section III**

a. *Column 1, Reference Code.* The code recorded in Column 6, Section II.

b. *Column 2, Remarks.* This column lists information pertinent to the maintenance function being performed as indicated in the MAC, Section II.

**Section II. MAINTENANCE ALLOCATION CHART**

(1) Group Number	(2) Component/Assembly	(3) Maintenance Function	(4) Maintenance Level					(5) Tools and Equipment	(6) Remarks
			C	O	F	H	D		
01	<b>ENGINE</b>								
0100	Engine Assembly	Inspect Test Service Replace Repair Overhaul	0.4	0.3 1.0	8.0	12.0 28.0			
0101	Crankcase, Block, and Cylinder Head								
	Cylinder Head	Replace Repair			2.0 2.0				
0102	Crankshaft	Replace				12.0			

**Section II. MAINTENANCE ALLOCATION CHART - Continued**

(1) Group Number	(2) Component/Assembly	(3) Maintenance Function	(4) Maintenance Level					(5) Tools and Equipment	(6) Remarks
			C	O	F	H	D		
			0104	<i>Pistons and Connecting Rods</i>	Replace Repair				
0105	<i>Valves, Camshafts, and Timing System</i>								
	Engine Valves	Adjust Replace		1.0	3.0				
	Timing Gears and Chain	Replace			2.0				
	Camshaft	Replace				7.0			
0106	<i>Engine Lubrication System</i>								
	Oil Pump	Inspect Replace Repair			0.3 1.5 1.5				
	Oil Filter	Service Replace Repair		0.2 1.0 1.0					
	Oil Pan	Replace Repair			1.0 1.0				
0108	<i>Manifolds</i>	Inspect Replace		0.2 1.5					
<b>03</b>	<b>FUEL SYSTEM</b>								
0301	<i>Carburetor, Fuel Injector</i>								
	Carburetor	Adjust Replace Repair		0.5 1.0	2.0				
	Governor	Adjust Replace		0.2 1.0					
0302	<i>Fuel Pumps</i>	Test Replace Repair		0.5 1.0 1.0					
0304	<i>Air Cleaner</i>	Service Replace Repair	0.3	0.2 0.2					
0306	<i>Tanks, Lines, Fittings, and Headers</i>								
	Tank, Fuel	Service Replace Repair	0.2	0.6		1.5			

**Section II. MAINTENANCE ALLOCATION CHART - Continued**

(1) Group Number	(2) Component/Assembly	(3) Maintenance Function	(4) Maintenance Level					(5) Tools and Equipment	(6) Remarks
			C	O	F	H	D		
0306	<i>Tanks, Lines, Fittings, and Headers (Con't)</i> Tube Assembly	Inspect Replace Repair	0.1	1.0	1.0				
0312	<i>Accelerator, Throttle or Choke Controls</i> Pedal and Linkage	Adjust Replace		0.3 0.5					
<b>04</b>	<b>EXHAUST SYSTEM</b>								
0401	<i>Muffler and Pipes</i>	Replace		1.0					
<b>05</b>	<b>COOLING SYSTEM</b>								
0501	<i>Radiator, Evaporative Cooler, or Heat Exchanger</i> Radiator	Inspect Test Service Replace Repair	0.2	0.1 1.5	1.0		2.0		
0503	<i>Water Manifold, Headers, Thermostats and Housing Gasket</i> Thermostats	Test Replace		0.5 0.5					
0504	<i>Water Pump</i>	Inspect Replace	0.1	0.5					
0505	<i>Fan Assembly</i> Belt, Fan	Inspect Adjust Replace	0.1	0.2 0.5					
<b>06</b>	<b>ELECTRICAL SYSTEM</b>								
0601	<i>Generator, Alternator</i> Generator	Test Replace Repair		0.5 0.5	1.5				

**Section II. MAINTENANCE ALLOCATION CHART - Continued**

(1) Group Number	(2) Component/Assembly	(3) Maintenance Function	(4) Maintenance Level					(5) Tools and Equipment	(6) Remarks
			C	O	F	H	D		
0602	<i>Generator Regulator (Voltage)</i>	Adjust		0.3					
		Replace		0.3					
0603	<i>Starting Motor</i>	Test		0.5					
		Replace		0.5					
		Repair			1.5				
0605	<i>Ignition Components</i>	<i>Distributor</i>	Adjust		0.2				
			Replace		0.5				
			Repair		1.0				
		<i>Spark Plugs</i>	Adjust		0.3				
			Replace		0.5				
0610	<i>Sending Units and Warning Switches</i>								
		<i>Fuel Sender</i>	Replace		0.4				
0611	<i>Horn</i>	<i>Button Assembly</i>	Test	0.1					
		Replace			0.3				
		Repair			0.3				
0612	<i>Batteries, Storage (Wet or Dry)</i>	Test		0.1					
		Service	0.2						
		Replace			0.3				
		Repair				2.0			
	<i>Cables, Battery</i>	Inspect	0.1						
		Replace			0.3				
0613	<i>Hull or Chassis Wiring Harness</i>	Replace		2.5					
		Repair			0.5				
07	<b>TRANSMISSION</b>								
0708	<i>Torque Converter or Fluid Coupling</i>								
		<i>Torque Converter</i>	Replace			2.0			
0710	<i>Transmission Assembly</i>	Test			1.0				
		Service	0.2	0.5					
		Adjust			0.5				
		Replace			8.0				
		Repair					12.0		
		Overhaul					16.0		



**Section II. MAINTENANCE ALLOCATION CHART - Continued**

(1) Group Number	(2) Component/Assembly	(3) Maintenance Function	(4) Maintenance Level					(5) Tools and Equipment	(6) Remarks
			C	O	F	H	D		
<b>09</b>	<b>PROPELLER, PROPELLER SHAFTS, UNIVERSAL JOINTS, COUPLER, AND CLAMP ASSEMBLY</b>								
0900	<i>Propeller Shafts</i>	Replace Repair		0.5 1.5					
	<i>Universal Joints</i>	Service Replace		0.2 0.5					
<b>10</b>	<b>FRONT AXLE</b>								
1000	<i>Front Axle Assembly</i>	Replace Repair			3.0 3.0				
	<i>Spindle, Wheel</i>	Service Replace Repair		0.4	4.0 4.0				
<b>11</b>	<b>REAR AXLE</b>								
1100	<i>Rear Axle Assembly</i>	Replace Repair			4.0 4.0				
1102	<i>Differential/Reduction Gear Case</i>	Service Replace Repair		0.2	4.0	4.0			
<b>12</b>	<b>BRAKES</b>								
1201	<i>Hand Brakes</i>								
	<i>Hand Brake Lever</i>	Adjust Replace		0.1 0.7					
1202	<i>Service Brakes</i>								
	<i>Service Brake Shoes</i>	Adjust Replace Repair		0.4 1.0 0.5					
1204	<i>Hydraulic Brake System</i>								
	<i>Brake Wheel Cylinders</i>	Replace		1.0					
	<i>Brake Master Cylinder</i>	Service Replace		0.1 1.0					
1206	<i>Mechanical Brake System</i>								
	<i>Pedal Assembly</i>	Service Replace Repair		0.1 0.5 0.5					

**Section II. MAINTENANCE ALLOCATION CHART - Continued**

(1) Group Number	(2) Component/Assembly	(3) Maintenance Function	(4) Maintenance Level					(5) Tools and Equipment	(6) Remarks
			C	O	F	H	D		
<b>13</b>	<b>WHEELS AND TRACKS</b>								
1311	Wheel Assembly	Replace Repair		1.0 1.0					
	Hub Assembly	Replace Repair		1.0 1.0					
	Wheel Bearings (Front Wheel)	Adjust Service Replace		0.2 1.0 1.0					
1313	Tires, Tubes, Tire Chains								
	Tires and Tubes	Inspect Service Replace Repair	0.1 0.1	1.0 0.5					
<b>14</b>	<b>STEERING</b>								
1401	Mechanical Steering Gear Assembly	Service Adjust Replace Repair		0.2	0.5 4.0 2.0				
	Drag Link	Service Adjust Replace Repair		0.3 0.2 2.0 0.5					
	Tie Rod	Service Adjust Replace Repair		0.3 0.5 2.0 0.5					
<b>15</b>	<b>FRAME, TOWING ATTACHMENTS, DRAW-BARS AND ARTICULATION SYSTEMS</b>								
1502	Counterweights	Replace		0.5					
1503	Pintles and Towing Attachments								
	Towing Attachments	Replace		0.3					

**Section II. MAINTENANCE ALLOCATION CHART - Continued**

(1) Group Number	(2) Component/Assembly	(3) Maintenance Function	(4) Maintenance Level					(5) Tools and Equipment	(6) Remarks
			C	O	F	H	D		
<b>16</b>	<b>SPRINGS AND SHOCK ABSORBERS</b>								
1601	<i>Springs</i>	Inspect Replace			0.2 2.0				
<b>18</b>	<b>BODY, CAB, HOOD AND HULL</b>								
1801	<i>Body, Cab, Hood and Hull Assemblies</i>								
	Hood Support Bracket	Replace		0.5					
1805	<i>Floors, Subfloors and Related Components</i>	Replace		0.3					
1806	<i>Upholstery, Seats and Carpets</i>								
	Seat	Adjust Replace Repair	0.1	0.5 1.0					

**Section III. TOOL AND TEST EQUIPMENT REQUIREMENTS**

Not Applicable.

**Section IV. REMARKS**

Not Applicable.

*Page I-1.* Delete entry for "Cylinder head removal, cleaning, inspection and installation".

*Page I-2.* Add "Horn button assembly, removal, inspection, repair, and installation, paragraph 5-51.1, page 4-42".

*Page I-3.* Add "Transmission, service by organizational maintenance, paragraph 4-11.1, page 4-1".

By Order of the Secretary of the Army:

Official:

WILLIAM J. MEEHAN II  
*Brigadier General, United States Army*  
*The Adjutant General*

CARL E. VUONO  
*General, United States Army*  
*Chief of Staff*

Distribution:

To be distributed in accordance with DA Form 12-25F (Block Nos. 2275, 2276),  
Operator and Unit maintenance requirements for Tractor, Warehouse, 4000 LB DBP,  
Pneumatic Tire, Gas (Model MHE-217).

★U.S. GOVERNMENT PRINTING OFFICE: 1990 743-024/20011

CHANGE }  
No. 2 }

HEADQUARTERS  
DEPARTMENT OF THE ARMY  
WASHINGTON, D.C., 19 April 1974

**Operator's and Organizational Maintenance Manual**  
**TRACTOR, WHEELED, WAREHOUSE, GASOLINE,**  
**PNEUMATIC-TIRED, 4,000 POUND DRAWBAR**  
**PULL (ARMY MODEL MHE-217, UNITED TRACTOR**  
**MODEL G40C) FSN 3930-181-3217**

TM 10-3930-626-12, 10 June 1971, is changed as follows:

*Inside Front Cover.* Add the following warnings to the inside front cover:

**WARNING**

Operation of this equipment presents a noise hazard to personnel in the area. The noise level exceeds the allowable limits for unprotected personnel. Wear ear muffs or ear plugs which were fitted by a trained professional.

**WARNING**

Dry cleaning solvent, P-D 680, used to clean parts is potentially dangerous to personnel and property. Do not use near open flame or excessive heat. Flash point of solvent is 100°F. -138°F.

*Page 1-1.* Paragraph 1-3 is superseded as follows:

**1-3. Reporting of Errors.** You can help to improve this manual by calling attention to errors and by recommending improvements, your letter or DA Form 2028 (Recommended Changes to Publications and Blank Forms) or by a letter, should be mailed direct to Commander, US Army Troop Support Command, ATTN: AMSTS-MPP, 4300 Goodfellow Blvd., St. Louis, MO 63120. A reply will be furnished direct to you.

*Page 2-5.* Immediately after Section IV title, add the following warning:

**WARNING**

Operation of this equipment presents a noise hazard to personnel in the area. The noise level exceeds the allowable limits for unprotected personnel. Wear ear muffs or ear plugs which were fitted by a trained professional.

*Page 4-1.* Immediately after Chapter 4 title, add the following warning:

**WARNING**

Dry cleaning solvent, P-D-680, used to clean parts is potentially dangerous to personnel and property. Do not use near open flame or excessive heat. Flash point of solvent is 100°F. -138°F.

*Page A-1, paragraph A-5.* Add the following reference: "TB MED 251, Noise and Conservation of Hearing".

By Order of the Secretary of the Army:

Official:

VERNE L. BOWERS

*Major General, United States Army*  
*The Adjutant General*

CREIGHTON W. ABRAMS  
*General, United States Army*  
*Chief of Staff*

Distribution:

To be distributed in accordance with DA Form 12-25A, (qty rqr block No. 893) Operator maintenance requirements for Warehouse, Equipment.

☆ U.S. GOVERNMENT PRINTING OFFICE: 1974-768117/1437

Change }  
No. 1 }

**Operator's and Organizational Maintenance Manual  
TRACTOR, WHEELED, WAREHOUSE , GASOLINE,  
PNEUMATIC-TIRED 4,000 POUND DRAWBAR  
PULL (ARMY MODEL MHE-217, UNITED TRACTOR  
MODEL G40C) FSN 3930-181-3217**

TM 10-3930-626-12, 10 June 1971, is changed as follows:

*Cover and title page.* Change the title to read as shown above and change the date to read 10 June 1971.

*Page 1-2.* Pages 1-2 and I-2 inadvertently reversed.

*Page 1-3.* In paragraph 1-5b (1), after item 5, add:

\*Steering gear housing ..... ¼ pt

*Page 1-4.* In paragraph 1-5b (4), in item 1, change the number of tires from 6 to 4. In paragraph 1-5b

(5), in item 11, change the governor speed from 3450 to 2400. In item 13, add after the present entry, "1-5-3-6-2-4". In item 38, change the governor speed from 2450 to 2400.

*Page 2-4.* Reverse paragraphs 2-8a and 2-8b. In paragraph 2-9b, line 8, change "left" to read "right."

*Page 2-6.* Paragraph 2-13d is superseded as follows:

d. Turn the ignition switch lever to the OFF position to stop the engine.

*Page 3-3.* In table 3-1, add the following:

Operator's maintenance category			Item to be inspected	Daily schedule (or weekly)	Paragraph reference
Interval and sequence number				Procedure	
Before Operation	During Operation	After Operation			
7	2		Fire extinguisher. Instruments	Inspect for broken seal and correct pressure. Check that all instruments indicate within the required ranges.	Para 2-22 Para 2-12e
	3		Controls	Check that controls perform as required.	Para 2-8

*Page 4-1.* In paragraph 4-9, line 9, add "(GAA)" between "grease" and "and". In paragraph 4-10's title, add a comma after "Link" and delete "and."

*Page 4-6.* In paragraph 4-22b (1), line 2, delete "start engine."

*Page 4-7.* In paragraph 4-22b (8), line 3, change "remove" to read "remote."

*Page 4-7.* In paragraph 4-23b (1), line 2, delete "or number six."

*Page 4-11.* In paragraph 4-26b (1), line 1 is changed to read as follows: "Crank engine by hand (using procedure in paragraph 4-22b and fig. 4-3) . . . mark."

*Page 4-13.* Paragraph 4-28 is rescinded.

*Page 4-15.* After paragraph 4-30, add paragraph 4-30.1 as follows:

**4-30.1 Water Pump, Fan, and Fan Belt**

*a. Removal.*

(1) Open the drain cocks in the engine block, lower the right corner of the radiator, and allow

the coolant to drain. If the coolant is clean, allow it to drain into a clean container and save it for reuse.

(2) Loosen the screw securing the adjusting arm to the generator (fig. 4-10). Push the generator toward the engine block to slacken the fan belt. Remove the fan belt from the fan and water pump pulley.

(3) Remove the four screws and lockwashers which secure the fan and pulley (fig. 4-11) to the water pump. Remove the fan, fan spacer, and pulley.

(4) Loosen the hose clamps on the bypass hose, and remove the hose from the water pump.

(5) Loosen the hose clamp on the lower radiator hose, and remove the hose from the water pump.

(6) Remove the 3 screws and lockwashers which secure the water pump to the engine block. Withdraw the water pump and gasket (fig. 4-11). Discard the gasket.

*b. Inspection.*

- (1) Inspect the water pump for secure mounting.
- (2) Inspect the water pump bearings for noise.
- (3) Inspect the water pump for evidence of coolant leakage.
- (4) Inspect the fan for secure mounting, and bent or cracked blades.
- (5) Inspect the fan belt for wear, fraying, and proper adjustment of 1/2-inch finger pressure deflection at midpoint between the generator pulley and fan pulley. Replace the belt if it is frayed, cracked, or deteriorated in any way.

*c. Installation.* Reverse the procedure in *a* above using a new water pump mounting gasket.

*d. Adjustment of Belt.*

- (1) Loosen the screw securing the adjusting arm to the generator (fig. 4-10) and loosen the generator mounting screws.
- (2) Pivot the generator for the desired belt tension (*b* above), and tighten the adjusting arm screw and generator mounting screw.

**NOTE**

All references to paragraph 4-28 in the basic manual are reflected in paragraph 4-30.1 of this change.

*Page 4-20.* In paragraph 4-37*b* (3) (b), line 1 is changed as follows: "Low pressure or volume indicates a . . . Paragraph 4-37*b* (3) (c), line 1, change "indicated" to "indicates."

*Page 4-21.* Paragraph 4-38*a* (1) is changed as follows: "(1) Hoist and securely block the tractor to obtain access to the fuel tank."

*Page 4-26.* In paragraph 4-44*b* (3) change line 1 to read: "Raise and securely block rear . . . working."

*Page 4-29.* After paragraph 4-46*b* (1), add:

**CAUTION**

Disconnect ground cable before removing or replacing electrical components. In paragraph 4-46*c* (2), line 1, change "Repolarize to "Polarize".

*Page 4-38.* Paragraph 4-48*a* is superseded as follows:

*a. Testing.* Make the following tests to isolate malfunctions.

- (1) *Testing starter resistance and current drain.*

(*a*) Test the vehicle battery electrolyte specific gravity. The specific gravity should be 1.220 or above. If the specific gravity is below 1.220, recharge the battery to a full charge before proceeding with the test.

(*b*) Disconnect the positive battery lead from the battery terminal post. Connect a 0- to 300-ampere ammeter between the disconnected lead and the battery terminal post.

(*c*) Connect a voltmeter between the battery positive post and the starter switch terminal at the starter solenoid.

(*d*) Crank the engine and observe the readings on the voltmeter and ammeter. Voltage should not exceed 0.3 volt. A reading that exceeds 0.3 volt indicates that there is high resistance caused from loose circuit connections, a faulty cable, a burned starter relay, or the solenoid switch contacts are bad. A current that is high and is combined with a slow cranking speed, indicates that the starter should be removed and repaired.

- (2) *Starter ground circuit test.*

(*a*) Connect the voltmeter positive lead to the starter housing and the negative lead to the battery negative post.

(*b*) Crank the engine with a remote control starter switch and observe the voltmeter reading. The voltmeter reading should not exceed 0.2 volt. If the voltmeter reading is greater than 0.2 volt, it indicates excessive voltage loss in the starter ground circuit. To isolate the point of excessive voltage loss, repeat the test at the starter drive housing, the cable terminal at the engine, and the cable clamp at the battery.

(*c*) A small change will occur each time a portion of the circuit is removed from the test. A definite change in the voltmeter reading indicates that the last part eliminated in the test is faulty. Maximum allowable voltage loss is 0.2 volt for the battery ground cable; 0.1 volt for the engine ground circuit, and 0.0 at each connection. Paragraph 4-48*b* (2) is changed to read as follows: "(2) Securely block . . . working". . . " After paragraph 4-49's heading, add:

**NOTE**

It is not necessary to remove the distributor in order to inspect, repair, or adjust it.

*Page 4-39.* In note after paragraph 4-49*c* (2), delete the words "believe to be".

*Page 4-42.* After paragraph 4-53*a* (3), add the following:

**CAUTION**

Care should be exercised that the rollers are not accidentally dropped from the trunion bearings.

*Page 4-44.* In paragraph 4-55*a* (2)(*f*), line 1, change 4-35 to "4-36".

*Page 4-45.* In paragraph 4-55*b* (2)(*a*), add, "and securely block" to the end of the sentence.

*Page 4-46.* In paragraph 4-56*a* (1), add, "and securely block" to the end of the sentence. In paragraph 4-56*b*(1), change paragraph reference to "4-62*a*". After paragraph 4-56*b*, add paragraph *b.1* as follows:

*b.1. Cleaning.* Clean all metal parts with approved cleaning solvent.



**NOTE**

Do not clean brake shoe linings or rubber parts with cleaning solvent; it will cause them to deteriorate.

*Page 4-51.* Paragraph 4-65a (1) is superseded as follows:

(1) Raise vehicle to a suitable working height and securely block it.

*Page 4-53.* In paragraph 4-65d, immediately after heading, add "Lubricate drag link with grease

(GAA)." In paragraph 4-65e, last sentence, add "new" between "insert" and "cotter."

*Page 4-53.* Paragraph 4-66a(1) is superseded as follows:

(1) Raise vehicle to a suitable working height and securely block it.

*Page 4-53.* Paragraph 4-66d. Immediately after heading add: "Lubricate tie rod with grease (GAA)."

*Page B-2.* In item 3, column 3A, add "O".

*Page B-3.* In item 7, column 3I is rescinded.

By Order of the Secretary of the Army:

Official:

VERNE L. BOWERS,  
*Major General, United States Army,  
The Adjutant General.*

CREIGHTON W. ABRAMS  
*General, United States Army,  
Chief of Staff.*

Distribution:

To be distributed in accordance with DA Form 12-25A, (qty rqr block No. 893) Operator Maintenance Requirements for Warehouse Equipment.



TECHNICAL MANUAL }  
 No. 10-3930-626-12 }

HEADQUARTERS  
 DEPARTMENT OF THE ARMY  
 Washington, D. C., 12 January 1971

**OPERATOR AND ORGANIZATIONAL MAINTENANCE MANUAL**

**TRACTOR, WHEELED, WAREHOUSE GASOLINE, PNEUMATIC-TIRED**

**4,000 POUND DRAWBAR PULL ARMY MODEL MHE E-217**

**UNITED TRACTOR MODEL C40C**

**FSN 3930-181-3217**

			Paragraph	Page
CHAPTER	1	INTRODUCTION		
Section	I	General . . . . .	1-1	1-1
	II	Description and data . . . . .	1-6	
CHAPTER	2	OPERATING INSTRUCTIONS		
Section	I	Service upon receipt of tractor . . . . .	2-1	2-1
	II	Movement to a new worksite . . . . .	2-5	2-1
	III	Controls and instruments . . . . .	2-7	2-2
	IV	Operation under usual conditions . . . . .	2-10	2-5
	V	Operation under unusual conditions . . . . .	2-15	2-6
	VI	Operation of auxiliary material . . . . .	2-22	2-7
		Used in conjunction with the equipment . . . . .	2-22	2-7
CHAPTER	3	OPERATOR MAINTENANCE INSTRUCTIONS		
Section	I	Basic issue items . . . . .	3-1	3-1
	II	Lubrication instructions . . . . .	3-2	3-1
	III	Preventive maintenance checks and services . . . . .	3-4	3-3
	IV	Operator's troubleshooting . . . . .	3-6	3-3
	V	Operator's maintenance of tractor . . . . .	3-8	3-4
CHAPTER	4	ORGANIZATIONAL MAINTENANCE		
Section	I	Service upon receipt of tractor . . . . .	4-1	4-1
	II	Repair parts, special tools, and equipment . . . . .	4-3	4-1
	III	Lubrication instructions . . . . .	4-6	4-1
	IV	Preventive maintenance checks and services . . . . .	4-12	4-2
	V	Troubleshooting . . . . .	4-14	4-3
	VI	Radio interference suppression . . . . .	4-16	4-4
	VII	Maintenance of positive crankcase ventilation system . . . . .	4-19	4-7
	VIII	Maintenance of basic engine . . . . .	4-21	4-7
	IX	Cooling system . . . . .	4-30	4-15
	X	Air intake and fuel system . . . . .	4-34	4-17
	XI	Oil filter system . . . . .	4-41	4-25
	XII	Exhaust system . . . . .	4-43	4-26
	XIII	Electrical system . . . . .	4-45	4-28
	XIV	Universal joints . . . . .	4-52	4-42
	XV	Brakes . . . . .	4-54	4-43
	XVI	Wheels, tires, and wheel bearings and springs . . . . .	4-59	4-48
	XVII	Steering . . . . .	4-64	4-51
CHAPTER	5	ADMINISTRATIVE STORAGE AND DESTRUCTION OF MATERIEL TO PREVENT ENEMY USE		
Section	I	Administrative storage . . . . .		5-1
	II	Demolition . . . . .		5-1

	Page
APPENDIX A REFERENCES . . . . .	A-1
B MAINTENANCE ALLOCATION CHART . . . . .	B-1
B BASIC ISSUE ITEMS LIST . . . . .	C-1
INDEX . . . . .	I-1

# LIST OF ILLUSTRATIONS

<i>Number</i>	<i>Title</i>	<i>Page</i>
1-1	Tractor, three quarter front view . . . . .	1-2
1-2	Tractor, three quarter rear view . . . . .	1-3
2-1	Location of controls and indicators . . . . .	2-3
3-1	Operator's daily service lubrication points . . . . .	3-2
3-2	Cooling system service points . . . . .	3-5
3-3	Servicing air cleaner . . . . .	3-7
3-4	Servicing battery . . . . .	3-8
4-1	Radio interference suppression components . . . . .	4-5
4-2	PC V installation . . . . .	4-6
4-3	Compression test . . . . .	4-7
4-4	Checking ignition timing . . . . .	4-8
4-5	Manifold vacuum test . . . . .	4-9
4-6	Partial view of right side of engine . . . . .	4-10
<del>4-7</del>	<del>Cylinder head bolt tightening sequence . . . . .</del>	<del>4-11</del>
4-8	Valve adjustment . . . . .	4-11
4-9	Engine manifolds, exploded view . . . . .	4-12
4-10	Fan belt and water pump installation . . . . .	4-13
4-11	Water pump, fan and fan belt . . . . .	4-14
4-12	Cooling system, exploded view . . . . .	4-16
4-13	Carburetor and linkage . . . . .	4-18
4-14	Fuel pump . . . . .	4-19
4-15	Fuel pump test setup . . . . .	4-20
4-16	Fuel tank installation . . . . .	4-22
4-17	Governor adjustment . . . . .	4-23
4-18	Accelerator pedal and throttle linkage . . . . .	4-24
4-19	Oil filter system . . . . .	4-25
4-20	Exhaust system . . . . .	4-27
4-21	Wiring diagram . . . . .	4-28
4-22	Hook-up for generator output test . . . . .	4-29
4-23	Checking cutout relay armature air gap . . . . .	4-31
4-24	Cutout relay contact point gap adjustment . . . . .	4-32
4-25	Cutout relay armature air gap adjustment . . . . .	4-33
4-26	Cutout relay test setup . . . . .	4-34
4-27	Spring anchor adjustment . . . . .	4-35
4-28	Checking voltage and current regulator air gap . . . . .	4-36
4-29	Voltage regulator test setup . . . . .	4-37
4-30	Current regulator test setup . . . . .	4-38
4-31	Distributor, installed . . . . .	4-39
4-32	Distributor, cap removed . . . . .	4-39
4-33	Testing moving contact spring tension . . . . .	4-39
4-34	Battery and cables . . . . .	4-41
4-35	Propeller shaft . . . . .	4-43
4-36	Parking brake lever and cable, exploded view . . . . .	4-44
4-37	Parking brake, exploded view . . . . .	4-45
4-38	Brake adjustment . . . . .	4-46
4-39	Brake system, exploded view . . . . .	4-47
4-40	Front wheels, tires, bearings, and hubs, exploded view . . . . .	4-49
4-41	Drive wheels, and tires, exploded view . . . . .	4-51
4-42	Tie rod and drag link, exploded view . . . . .	4-52

Doc. No. 3



# CHAPTER 1

## INTRODUCTION

### Section 1. GENERAL

#### 1-1. Scope

*See 1-1*  
a. This manual is published for use of personnel responsible for operation and organizational maintenance of the Tractor Wheeled, Warehouse, Gasoline, Pneumatic-Tired, 4,000 pound Drawbar Pull, United Tractor Model G40C, Army Model MHE-217, Federal Stock Number 3930-181-3217, procured under Contract Number DSA 400-70-C-4251.

b. This manual provides the operator with the necessary operating instructions and with instructions for performing maintenance services which are the responsibility of the operator. This manual provides organizational maintenance personnel with the necessary information for performing the maintenance services which are the responsibility of organizational maintenance. Throughout this manual the use of the terms right, left, front, and rear with respect to the parts of the tractor indicates directions from the viewpoint of the operator sitting in the seat of the tractor.

c. Appendix A contains a list of publications applicable to this manual. Appendix B is the maintenance allocation chart applicable to this equipment. Appendix C contains the basic issue items list and special tools list.

~~1-2. Forms and Records~~ *Supersedes 1-2*  
~~Maintenance forms, records, and reports for use and prescribed by personnel at all maintenance levels are listed in and prescribed by TM 30-750.~~ *3*

#### 1-3. Reporting of Errors

~~Report of errors, omissions, and recommendations for improving this publication by the individual user is encouraged. Reports should be submitted on DA Form 2808, (Recommended Changes to Publications) and forwarded direct to Commanding General, U.S. Army Mobility Equipment Command, ATTN: AMSME-MPP, 4300 Goodfellow Boulevard, St. Louis, Mo. 63120.~~ *M*

### Section II. DESCRIPTION AND DATA

#### 1-4. Description

Army Model MHE-217 (fig. 1-1 and 1-2) United Tractor Model G-40C) is a gasoline powered, front-wheel steered, rear-wheel driven materials handling tractor. The tractor is powered by a six-cylinder, in-line, four cycle, L-head, liquid cooled, gasoline engine. Torque is transmitted through an automatic transmission with three forward speeds and a single reverse coupled to the engine through a torque converter. The transmission output shaft is

coupled to the drive axle through a short propeller shaft. A drop gearbox on the drive axle provides further speed reduction between transmission and rear wheels. Foot-operated hydraulic drum-type brakes are provided at the rear wheels. A hand-operated mechanical braking system is provided for parking the vehicle. The steering mechanism incorporates a recirculating ball type steering gear, drag link, and tie rod. The electrical system includes head-lights, stoplight-tailights, and horn.

	Paragraph	Page
Engine, operator's preventive maintenance . . . . .	3-9	3-4
Engine, timing adjustment . . . . .	4-49	4-38
Exhaust pipe, inspection, removal, and installation . . . . .	4-44	4-26
Fan, removal, inspection, and installation . . . . .	4-28	4-13
Fan belt adjustment . . . . .	4-28	4-14
Fan belt, adjusting upon receipt. . . . .	2-3	2-1
Fan belt, deflection of when adjusted . . . . .	1-7	
Fan belt, removal, inspection, and installation . . . . .	4-28	4-13
Filter, oil, removal, cleaning, inspection, and installation . . . . .	4-42	4-25
Fire extinguisher, description. . . . .	2-22	2-7
Fire extinguisher, installing on receipt . . . . .	2-4	2-1
Fire extinguisher, maintenance of. . . . .	2-24	2-7
Fire extinguisher, operation . . . . .	2-23	2-7
Forms and records . . . . .	1-2	1-1
Fuel gage, location and purpose of . . . . .	2-9	2-4
Fuel pump, characteristics of. . . . .	1-7	
Fuel pump, cleaning, testing, removal, and installation . . . . .	4-37	4-18
Fuel tank, capacity of . . . . .	1-7	
Fuel tank, operator's service. . . . .	3-13	3-7
Fuel tank, removal, cleaning and installation . . . . .	4-38	4-21
Fuel tank, service upon receipt. . . . .	2-3	2-1
Gearcase, drop, description of. . . . .	1-0	
Gearcase, drop, service upon receipt . . . . .	2-3	2-1
Generator, characteristics of. . . . .	1-7	
Generator, testing, removal, and installation. . . . .	4-46	
Generator regulator, characteristics of . . . . .	1-7	
Governor, adjustment . . . . .	4-39	4-23
Headlight switch, description and location of . . . . .	2-8	2-4
Hoisting . . . . .	2-5	2-1
Horn button, location and use of. . . . .	2-8	2-4
Hoses, radiator, inspection, removal, and installation . . . . .	4-31	4-15
Hour meter, location and purpose of . . . . .	2-9	2-4
Identification of tractor . . . . .	1-7	
Ignition switch, description and location of . . . . .	2-8	2-4
Left hand, definition. . . . .	1-5	
Lubrication, care of . . . . .	4-7	4-1
Lubrication points, cleaning. . . . .	4-8	4-1
Lubrication points serviced by operator . . . . .	3-3	3-1
Lubrication, operator's, detailed information . . . . .	3-3	3-1
Lubrication, operator's, general information . . . . .	3-2	3-1
Lubrication, organizational maintenance. . . . .	4-6	4-1
Manifolds, intake and exhaust, removal inspection and installation . . . . .	4-27	4-11
Master cylinder, access for service . . . . .	4-11	4-1
Master cylinder, brake, inspection, removal and installation . . . . .	4-57	4-48
Master cylinder, characteristics of . . . . .	1-7	
Moving to new worksite . . . . .	2-5	2-1
Muffler, inspection, removal, and installation . . . . .	4-44	4-26
Oil filter, removal, cleaning, inspection, and installation . . . . .	4-42	4-25
Oil pressure gage, location and purpose of . . . . .	2-9	2-4
Operation, extreme cold conditions . . . . .	2-15	2-6
Operation, extreme heat. . . . .	2-16	2-6
Operation, high altitudes . . . . .	2-21	2-7
Operation, normal conditions. . . . .	2-11—2-14	2-5—2-6
Operation, rainy or humid conditions . . . . .	2-18	2-7
Operation, salt water areas . . . . .	2-19	2-7
Operation, sandy or dusty conditions . . . . .	2-17	2-6
Operation, snow or mud . . . . .	2-20	2-7
Orientation . . . . .	1-5	1-3
Parking brake, adjustment and repair . . . . .	4-55	4-43
Parking brake, description of. . . . .	1-6	
Parking brake cable, removal and installation . . . . .	4-55	4-43
Parking brake lever, adjustment, removal, cleaning, inspection and installation, . . . . .	4-55	4-43
Parking brake lever, location and use of . . . . .	2-8	2-4
Performance characteristics . . . . .	1-7	
Pintle release cable, location and use of . . . . .	2-8	2-4
Positive crankcase ventilation, description of . . . . .	4-19	4-6

X-2  
1-2



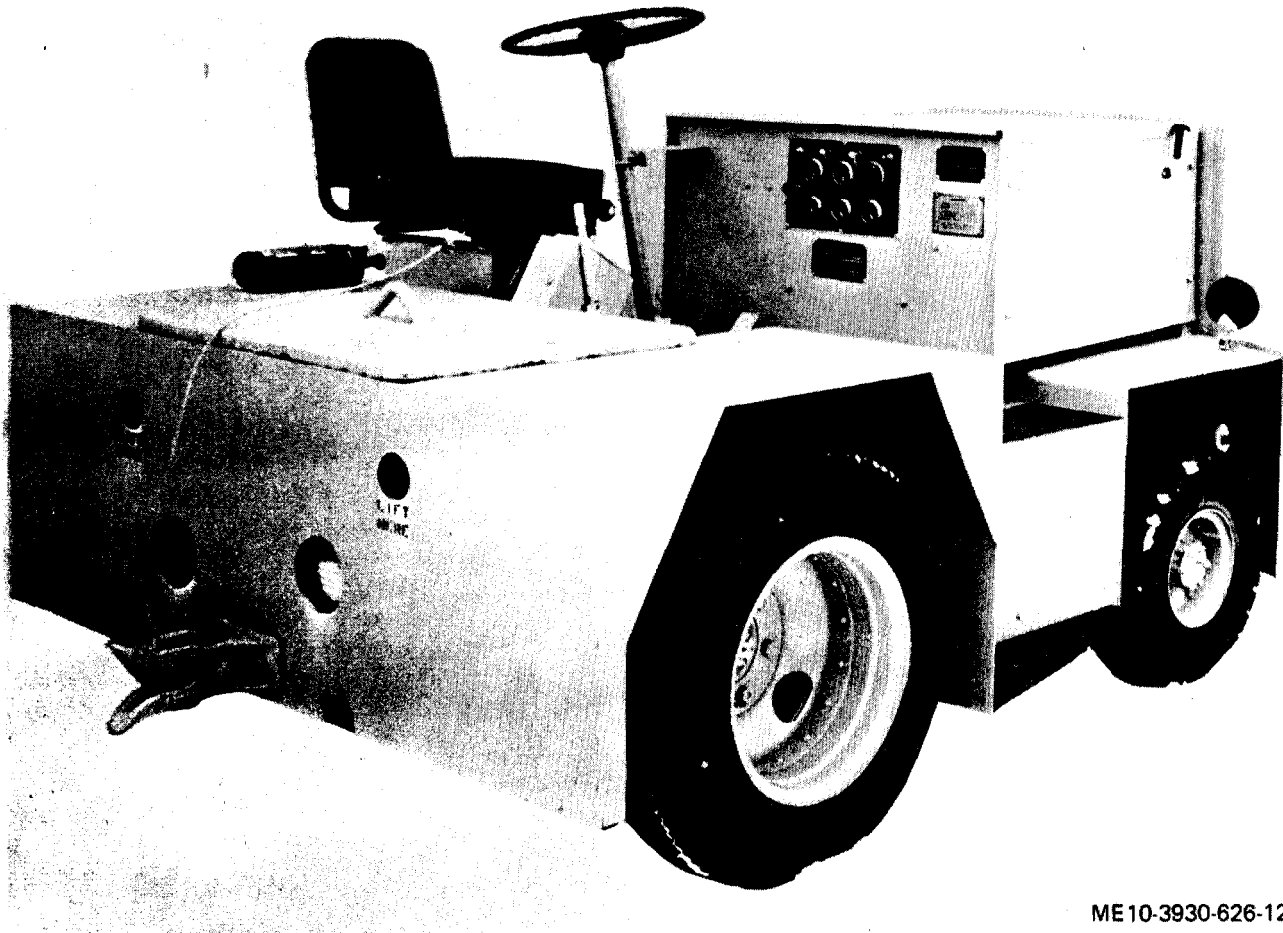

ME10-3930-626-12/1-2

Figure 1-2. Tractor, three-quarter rear view.

1-5. Identification and Tabulated Data

a. *Identification.* An identification plate is mounted on the operator's side of the engine firewall directly below the instrument panel. This plate specifies the nomenclature, model, serial number, Federal Stock Number, Contract Number, delivery date, and capacity of the tractor.

Manufacturer . . . . . United Tractor, Inc.  
 Model . . . . . G40C  
 Serial Number Range . . . . . 10301 thru 11018

b. *Tabulated Data.*

(1) *Capacities.*

Cooling system . . . . . 14½ qt  
 Crankcase . . . . . .6 qt  
 Fuel tank . . . . . 13 gal  
 Hydraulic brake system . . . . . 1 pt  
 Steering gear *Remaining* . . . . . 1½ pt *3/4*  
 Transmission and torque converter . . . . . 8 qt  
 Drop gearcase . . . . . .1½ pt  
 Differential . . . . . 9½ pt

*Acc  
 Ch. 3*

(2) *Performance.*

Towing capacity:  
 Level . . . . . 160,000 lb  
 On grade (ascending or descending):  
 2 percent . . . . . 83,800 lb  
 4 percent . . . . . 56,200 lb  
 6 percent . . . . . 41,800 lb  
 8 percent . . . . . 32,800 lb  
 10 percent . . . . . 26,800 lb  
 12 percent . . . . . 22,400 lb  
 14 percent . . . . . 18,200 lb  
 Speed (maximum):  
 Forward . . . . . 13 mph  
 Reverse . . . . . 6½ mph  
 Turning radius:  
 Inside . . . . . 46 in.  
 Outside . . . . . 130 in.  
 Approach angle (maximum) . . . . . 23 deg  
 Departure angle (maximum) . . . . . 18 deg  
 Negotiable grade (maximum unloaded) . . . . . 15 deg

(3) *Dimensions and weight.*

Length .....99 in.  
Width .....65.5 in.  
Height .....58 in.  
Weight (shipping) . 5,000 lb

(4) *Tires.*

Rear (drive):  
Number ..... ~~6~~ 4  
Size ..... 6.50 x 16  
Ply rating .....6  
Inflation pressure..... 45 psi  
Front (steer):.....  
Number .....2  
Size ..... 6.00 x 9  
Ply rating .....6  
Inflation pressure..... 45 psi

(5) *Engine and accessories.*

Engine:  
Make ..... Chrysler Industrial  
Model ..... 931-1631-1  
Type ..... 4 cycle  
Number of cylinders ..... 6  
Arrangement..... In-line  
Bore ..... 3.25 in.  
Stroke ..... 4.62 in.  
Piston displacement ..... 230 cubic in.  
Compression ratio ..... 7.0 to 1  
Compression at cranking  
speed (150 rpm) ..... 130 to 140 psi  
Governed speed..... ~~2,450~~ rpm  
Horsepower rating at 2800  
rpm ..... ~~66~~ 2,400 .66  
Firing order (number 1  
cylinder at fan end) 1-5-3-6-2-4  
Valve lash:  
Intake (cold) ..... 0.010 in.  
Exhaust (cold)..... 0.016 in.  
Spark plugs:  
Size ..... 14mm  
Gap ..... 0.035 in.  
Distributor:  
Point gap ..... 0.018 to 0.022 in.  
Contact point pressure ..... 17 to 22 oz.  
Condenser rating..... 0.25 uf  
Timing (BTC at idle rpm) 0 deg  
Timing mark location . . . Crankshaft pulley  
Generator:  
Voltage ..... 12 volts  
Current rating . . . . 30 amps  
Generator regulator:  
Cut-out relay armature gap 0.025 to 0.027 in.  
Current regulator armature  
gap ..... 0.048 to 0.052 in.  
Voltage regulator armature  
gap ..... 0.048to 0.052 in.  
Cut-out relay contact gap . 0.015 in.  
Cut-out relay closing voltage 12.6 to 13.6 volts  
Current regulator amps  
at 70°F ..... 3.0 to 3.5 amps  
Voltage regulator volts  
at 70°F ..... 14.2 to 14.8 volts  
Ground polarity..... Negative

Fuel pump:

Delivery rate (under test  
conditions)..... 2 pt per min  
Pump pressure (under test  
conditions) ..... 3½ psi

Carburetor:

Idle speed adjustment . . . 450 to 500 rpm  
Idle mixture-maximum  
vacuum ..... 18 to 20 in. Hg  
Thermostat (nominal) 180°F  
Governor speed setting . . . . ~~2,450~~ rpm  
Radiator pressure cap  
setting ..... 4 psi  
Fan belt deflection at  
midpoint ..... ½ in.

(6) *Steering gear.*

Type ..... Recirculating ball nut  
Manufacturer . . . . . Ross Gear  
Part number ..... TE55030  
Tiered toe-in ..... 1/8 in.  
Steering wheel rotation  
(lock-to-lock)..... 6 rotations

(7) *Brake master cylinder.*

Manufacturer..... Wagner  
Part number ..... FE342240

(8) *Transmission.*

Type ..... Automatic  
Manufacturer..... Chrysler  
Series ..... G

(9) *Rear (drive) axle.*

Manufacturer . . . . . Rockwell Standard  
Part number ..... TA267FSH  
Drop case reduction ratio . . . 3.0 to 1  
Differential reduction ratio . . . 5 4/6 to 1  
Brake type . . . . . Drum hydraulic  
Brake shoe size ..... 12½ in. x 2½ in.

(10) *Battery.*

Type ..... Lead-acid  
Rating ..... 55 Ampere Hour  
Specific gravity of electrolyte  
Full charge (at 80°F) ..... 1.280  
50 percent charge (at 80°F) 1.220  
Discharged (at 80°F) ..... 1.160

(11) *Torquing values for threaded fasteners.*

Cylinder head bolts..... 65-70 ft-lb  
Other fasteners:  
¼ inch ..... 8 to 10 ft-lb  
5/16 inch ..... 15 to 18ft-lb  
3/8 inch ..... 10 to 35ft-lb  
7/16 inch ..... 50 to 5.5ft-lb  
½ inch ..... 7.5 to 85ft-lb  
9/16 inch ..... 115 to 125 ft-lb  
5/8 inch ..... 155 to 170ft-lb  
3/4inch ..... 270 to 300 ft-lb

ch 3

## CHAPTER 2

### OPERATING INSTRUCTIONS

---

#### Section I. SERVICE UPON RECEIPT OF TRACTOR

##### 2-1. General

When a new or used tractor is received by a using organization, it must be serviced as described in paragraphs 2-3 and 2-4 before any operation is attempted.

##### 2-2. Responsibilities

Services upon receipt of a tractor are the responsibility of the using organization. These services must be performed by organizational maintenance personnel. The operator may assist in these services if so directed by the commanding officer

##### 2-3. Inspecting and Servicing the Tractor

*a. Removal of Tape.* Remove all tape used to seal engine breathers and dipstick, fuel tank vent, torque converter breather, engine intake and air cleaner, generator openings, and exhaust pipe.

*b. Removal of Preservatives.* Remove preservative compound from all unpainted metal surfaces, including propeller shaft universal joints, with SD (solvent, dry-cleaning). Since this compound is not a lubricant, use care to insure that it is removed from all wearing surfaces.

*c. Servicing Cooling System.* Check level of coolant. If low, add a premixed solution of 50 percent antifreeze conforming to Federal Specification O-A-548 and 50 percent water.

*d. Servicing Engine Crankcase.* Drain preservative oil from crankcase and refill to operating level with oil specified in lubrication order.

*e. Adjusting Engine Fan Belt.* Adjust engine fan belt for ½ inch deflection.

*f. Servicing Fuel Tank.* Open fuel tank shutoff valve located underneath fuel tank. Fill tank with gasoline.

*g. Servicing Battery.* Remove seals from filler

caps. Remove barrier material and preservative from battery terminals. Connect battery cables to battery terminals. Pour electrolyte (separately packaged) into battery cells until plates are covered.

**Warning:** Do not allow electrolyte to come in contact with skin. Avoid breathing fumes. If electrolyte comes in contact with skin, wash immediately with large quantity of water. If electrolyte splashes in eyes, wash immediately with large quantity of water and obtain immediate medical assistance.

*h. Servicing Torque Converter and Transmission.* Drain preservative oil from torque converter and automatic transmission. Refill to operating level with fluid specified in lubrication order.

*i. Servicing Drop Gear Case and Differential.* Check level of lubricant. If low, add lubricant as specified in lubrication order.

*j. Servicing Hydraulic Brake System.* Check level of fluid. If low, add fluid as specified in lubrication order. Remove blocking from brake pedal. Adjust brakes as described in paragraph 4-56.

*k. Servicing Hand (Parking) Brake.* Adjust parking brake as described in paragraph 4-55.

*l. Servicing Tires.* Check pressure in each tire. Increase or reduce pressure to meet inflation requirements (45 psi front and rear).

##### 2-4. Installing Separately Packaged Items

*a. Seat Cushion.* Unpack seat cushion and install it in the seat frame.

*b. Fire Extinguisher.* Install fire extinguisher and bracket below and to the left of the operator's seat.

#### Section II. MOVEMENT TO A NEW WORKSITE

##### 2-5. Dismantling for Movement

*a.* If the new worksite is near, the tractor may be driven to the new location provided that the ground or pavement is within the performance limits for the tractor. No dismantling or special preparation is required under these conditions. If the surface over which the tractor must be driven is not suitable, load the tractor onto a truck, trailer, or other carrier.

*b.* If the tractor is to be moved to a distant worksite, proceed as follows:

(1) Load the tractor onto a truck, trailer, or other carrier.

*Note.* Two lifting holes (for insertion of cable hooks) are provided at the front and rear of the tractor. When using cables and hooks, be sure to provide packing or blocking between cables and surfaces of the tractor to prevent damage to the painted surfaces.

(2) Drain gasoline from fuel tank.

(3) Disconnect cables from battery terminals.  
Battery may be left mounted in tractor.

#### **2-6. Reinstallation After Movement**

When tractor arrives at new worksite, refill fuel

tank and reconnect battery cables. Tractor is then ready for service.

### **Section III. CONTROLS AND INSTRUMENTS**

#### **2-7. General**

This section furnishes you with illustrations and information concerning the controls and indicators

you will use in operating the tractor. The controls and indicators are shown in figure 2.1.

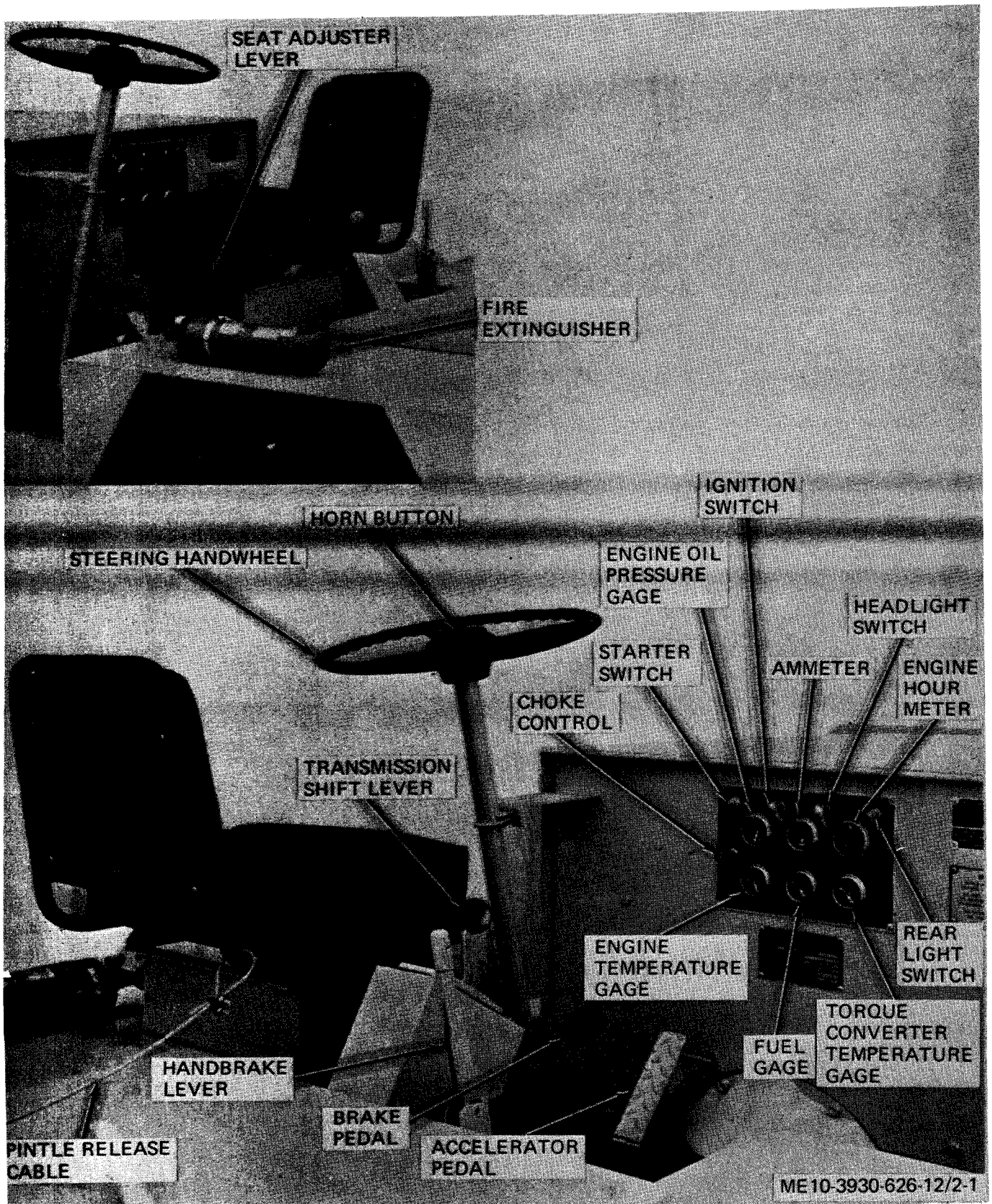

Figure 2-1. Location of controls and indicators.

Attach 3

## 2-8. Controls

*W. Starter Switch.* The starter switch is located in the upper left corner of the instrument panel. Depressing the switch energizes the starter solenoid which in turn causes the starter motor to crank the engine. This control is effective only when the transmission shift lever is in the neutral position. Release the knob when the engine starts.

*W. Ignition Switch.* The ignition switch is located to the right of the starter switch on the instrument panel. Turn the switch lever to ON position to activate the engine ignition system prior to attempting to start the engine. This switch also activates the electrical circuits for the instruments. Turn the lever to OFF position to stop the engine.

*c. Headlight Switch.* The headlight switch is located on the instrument panel to the right of the ignition switch. Turn the switch lever to ON position to turn on the headlights.

*d. Rear Light Switch.* The rear light switch is located in the upper right corner of the instrument panel. Pull the switch knob out to turn on rear light. Push switch knob into turn off rear light.

*e. Brake Pedal.* The brake pedal is located on the floor to the right of the steering column. Use your right foot to depress the brake pedal to decrease forward or reverse speed. The stoplight on the rear of the tractor will come on when the pedal is depressed.

*f. Accelerator Pedal.* The accelerator pedal is located on the floorboard to the right of the brake pedal. Use your right foot on the accelerator pedal. Depressing the pedal causes an increase in engine speed. Release pressure on the pedal to decrease engine speed.

*g. Transmission Shift Lever.* The transmission shift lever is located to the right of the operator's seat. Always place the lever in the N (neutral) position before attempting to start the engine. To move the tractor forward, place the lever in D, 1, or 2 position. For reverse, place the lever in the R position.

*h. Parking Brake Lever.* The parking brake lever is located to the right of the operator's seat, convenient for right-hand operation. Pull lever upward and back to apply the parking brake. Push the lever forward and down to release the parking brake.

*i. Steering Handwheel.* The steering handwheel controls the direction of travel. Turn the handwheel to the right (clockwise) to make a right turn; toward the left to make a left turn.

*j. Horn Button.* The horn button is located in the center of the steering handwheel. Depress the button to sound the horn.

*k. Choke Control.* The choke control is located on the left side of the instrument panel. The normal position of the control during tractor operation is all

the way in. Pull the choke control out when starting the engine in cold weather. As engine warms up, push control as required for smooth engine operation.

*l. Seat Adjuster Lever.* The seat adjuster lever is located on the left side of the operator's seat. Depress the lever toward the seat; then you can move the seat forward or backward as desired. Release the lever to lock the seat in the selected position.

*m. Pintle Release Cable.* The operator's end of the pintle release cable is attached to the frame of the operator's seat. A pull on the cable will release the pintle hook.

## 2-9. Indicators

*a. Engine Oil Pressure Gage.* The engine oil pressure gage is located in the upper left corner of the instrument panel. The gage dial reads from 0 to 60 psi. This gage registers to pressure of the engine lubricating oil during engine operation. Under normal operating speeds, the gage should read 45 to 55 psi. A higher pressure reading is normal when the engine is operating cold. If the gage reading is low or excessively high, stop the engine and report the condition to the proper authority.

*b. Ammeter.* The ammeter is located on the instrument panel to the right of the oil pressure gage. The ammeter indicates the amount of current flowing to or from the battery. The dial reads from -40 to +40 amperes. A minus reading indicates battery discharge. A plus reading indicates battery charging. When the engine is first started, the ammeter needle should move far to the ~~left~~ (indicating high charging rate). The needle should drop back toward the center of the dial and remain slightly on the plus side. With the engine idling and the headlights on, the ammeter should read a minus value. If the ammeter shows a constant discharge (even a slight amount), report the condition to the proper authority.

*c. Engine Hour Meter.* The engine hour meter is located in the upper left corner of the instrument panel. The meter indicates the total hours of engine operation. The meter contains number wheels which indicate hours to the nearest tenth of an hour.

*d. Engine Temperature Gage.* The engine temperature gage is located in the lower right corner of the instrument panel. The gage reads from 100 to 220 degrees F, indicating engine coolant temperature. During normal operation (after engine warmup) the gage should read 160 to 180 degrees. If the gage fails to show any temperature gain after normal warmup time or if the gage reads above 210 degrees F., stop the engine; and, report the condition to the proper authority.

*e. Fuel Gage.* The fuel gage is located in the lower center of the instrument panel. The gage

registers the amount of gasoline in the fuel tank. The dial is marked E,  $\frac{1}{4}$ ,  $\frac{1}{2}$ ,  $\frac{3}{4}$ , and F.

*f. Torque Converter Temperature Gage.* The torque converter temperature gage is located in the lower right corner of the instrument panel. The gage indicates the temperature of the fluid in the

torque converter. The dial reads from 100 to 360 degrees F. Any reading below 250 degrees is normal. If the reading exceeds 250 degrees, stop operation of the tractor immediately and report the condition to the proper authority.

## Section IV. OPERATION UNDER USUAL CONDITIONS

### 2-10. General

*a.* The instruction in this section are for the information and guidance of personnel responsible for the operation of the tractor.

*b.* The operator must know how to perform every operation of which the tractor is capable. This section contains instructions on starting and stopping the tractor, on operation of the tractor, and on coordinating the basic motions to perform the specific tasks for which the tractor was designed. Since nearly every job presents a different problem, you may have to vary the procedures to fit the individual job.

### 2-11. Starting the Tractor

*Note.* Before the first startup on any particular day, perform the daily preventive maintenance services described in paragraph 3-5.

*a.* Pull up on the parking brake lever (fig. 2-1). This will set the parking brake and prevent the tractor from rolling.

*b.* If necessary, adjust the operator's seat for comfortable reach of brake and accelerator pedals with right foot and comfortable reach of steering handwheel with hands.

*c.* Set transmission shift lever in N (neutral) position.

*d.* If engine is cold, pull choke control all the way out.

*e.* Depress accelerator pedal approximately one third of total pedal travel.

*f.* Turn ignition switch lever to ON position.

*g.* Depress starter switch button. When engine starts, release starter switch button.

**Caution: Do not keep starter switch button depressed continuously for more than 30 seconds while trying to start engine. If engine fails to start within 30 seconds, release starter switch button. Allow starter motor to cool for at least two minutes before attempting to start engine again.**

**Caution: Do not depress starter switch button when engine is running. If operating location is so noisy that a running engine cannot be heard, visually check for engine operation before depressing starter switch button.**

**Caution: Do not race engine when cold. Lack of lubrication on internal parts can cause rapid engine wear.**

*h.* Hold accelerator pedal slightly depressed to obtain a steady fast idle engine speed, and allow engine to warm up.

*i.* Immediately after starting engine and during warm up, check for normal readings of engine oil pressure gage (para 2-9 *a*), ammeter (para 2-9 *b*), and engine temperature gage (para 2-9 *d*).

*j.* As engine warms up, gradually push choke control in. Continue to warm up engine until it will run smoothly with choke control all the way in.

*k.* Check that engine hour meter (para 2-9 *c*) is operating.

*l.* Remove your foot from the accelerator pedal and check that engine settles into smooth slow-idling speed.

*Note.* Tractor may be started by pushing if the battery is dead. To start under these conditions, set shift lever in N position and release brakes. With an assistant pushing tractor with another vehicle, allow speed to reach approximately 15 mph. Then shift lever into D position.

*Note.* If any difficulties or malfunctions are noted during starting, report the conditions to the proper authority.

### 2-12. Driving the Tractor

*a.* Check fuel supply by noting fuel gage (para 2-9 *f*) to insure that you have enough fuel to accomplish your task. Refuel if necessary.

*b.* Move the transmission shift lever into position D, 1 or 2 for forward travel or into position R for reverse travel.

*Note.* Use position D for normal forward driving and light towing on level surface. Use 1, and 2 positions when ascending or descending steep grade unloaded or when towing heavy load on level or grade.

*c.* Place right foot on accelerator pedal. Slowly depress accelerator pedal while releasing parking brake. Continue to depress accelerator pedal until tractor starts to move and attains safe operating speed.

*d.* When approaching ascending or descending grade while operating in D or 1 position, shift to 2 position as required.

*e.* During driving operation, observe conditions as follows:

(1) Observe engine temperature gage for proper engine temperature (para 2-9 d).

(2) Observe ammeter for battery charge/discharge (para 2-9 b).

(3) Observe engine oil pressure gage for proper oil pressure (para 2-9 a).

(4) Observe torque converter temperature gage for evidence of transmission overheating (para 2-9 f).

(5) Observe fuel gage for adequate fuel supply (para 2-9 e).

(6) Observe engine hour meter to insure that running time of engine is being registered (para 2-9 c).

*Note.* If tractor fails to operate properly or abnormal conditions are observed, stop the tractor; and, report the condition to the proper authority.

*f.* To slow forward or reverse travel, remove your foot from accelerator pedal; and, depress brake pedal.

### 2-13. Stopping the Tractor

*a.* Apply gradual pressure to brake pedal with your right foot. Bring the tractor to a smooth stop. Avoid sudden stops.

**Caution:** The distance required to bring the tractor to a full stop from a given speed will

**depend on grade and load. Be sure you take these conditions into consideration in deciding on a safe operating speed.**

*b.* When tractor comes to a full stop, apply parking brake.

*c.* Place transmission shift lever in N (neutral) position.

~~*d. Push in the ignition switch knob to stop engine.*~~ *Superintendent*

### 2-14. Safety Precautions

*a.* Be alert for other workers to be sure they are not in the way of the moving tractor or towed load.

*b.* Avoid sudden starts and stops.

*c.* Use your headlights when operating the tractor at night or in a darkened area.

*d.* Know the rated capacity of the tractor and do not overload it.

*e.* Do not operate the tractor on soft ground or other surface where tractor is likely to get bogged down or overturned.

*f.* To prevent unnecessary battery discharge, turn off headlights and taillights when use is not required and engine is stopped.

*g.* Promptly report any evidence of faulty tractor performance.

## Section V. OPERATION UNDER UNUSUAL CONDITIONS

### 2-15. Operation In Extreme Cold (Below 0°F (-18°C))

*a.* If possible, store the tractor in a heated building or shelter. If a shelter is not available, park the tractor with the rear end facing into the wind and cover the tractor with a tarpaulin.

*b.* See that the cooling system contains artic-type antifreeze. Check the coolant with a hydrometer to be certain the system is protected against the lowest anticipated temperature. If antifreeze is not available, have the cooling system drained when the tractor is not in use. Attach a tag to the steering hand wheel to warn personnel that the cooling system has been drained.

*c.* Keep the battery fully charged. Run the engine for at least one hour after adding water to the battery. Remove and store the battery in a warm place if the tractor is not parked in a shelter.

*d.* Keep the fuel tank full when not in operation.

*e.* Allow the engine to reach normal operating temperature before applying load.

### 2-16. Operation in Extreme Heat

*a.* Check the fan belt for tightness. Where finger pressure is applied midway between the pulleys, the belt should be deflected ½ inch. Too loose a fan belt allows slippage resulting in lowered water pump output and a possible engine overheating.

*b.* Maintain the coolant level at the bottom of the filler cap neck. Be sure the radiator pressure cap is on tight.

*c.* Keep the external parts of the radiator clean and free of obstructions. Good air circulation is important.

*d.* Have the cooling system cleaned and flushed frequently.

*e.* Maintain the level of the battery electrolyte ½ inch above the plates. Have the specific gravity of the electrolyte checked frequently.

### 2-17. Operation in Dusty or Sandy Areas

*a.* Take precautions to prevent sand and dust from entering the fuel system. Make a bag of single-layer cloth and loosely tie it over the entire air cleaner during sandstorms. Clean the fuel filter and air cleaner daily.

*b.* Remove sand from axles, wheels, steering spindles, radiator, and brake assemblies.

*c.* Clean all lubrication points thoroughly before applying lubricants.

*d.* Shield the tractor from the dust and sand as much as possible when not in use. Take advantage of natural barriers to dust and sand if storage shelter is not available.



### **2-18. Operation Under Rainy or Humid Conditions**

*a.* If the tractor is not in operation and unsheltered, protect it with a canvas or other waterproof covering. Remove the cover during dry periods. Corrosion of the metal may occur quickly where paint is chipped or scratched.

*b.* Inspect the tractor often for exposed, damaged or corroded metal surfaces and report the condition to the proper authority.

### **2-19. Operation in Salt Water Areas**

*a.* Wash the tractor frequently with clean, fresh water. Be especially careful to clean salt deposits from electrical components and wiring.

*b.* Coat exposed metal surfaces with rust-proofing material. Remove rust immediately and apply paint or oil as appropriate.

### **2-20. Operation in Snow or Mud**

*a.* While operating the tractor, be alert for sharp drop offs or holes hidden beneath the mud or snow.

*b.* Slightly deflated drive wheel tires will improve traction in loose snow or mud. Reinflate tires when back on solid ground.

### **2-21. Operation in High Altitudes**

*a.* See that the radiator pressure cap is on tight. Check the fan belt for tightness (para 2-16 *a*). Engine overheating may occur at high altitude under heavy load.

*b.* Engine performance may be improved by replacing the standard carburetor main metering jet with a 1 size lean jet when operating between approximately 5,000 to 10,000 feet above sea level; a 2 size lean jet between approximately 10,000 to 15,000 feet, and a 3 size lean jet between approximately 15,000 to 20,000 feet.

## **Section Vi. OPERATION OF AUXILIARY MATERIAL USED IN CONJUNCTION WITH THE EQUIPMENT**

### **2-22. Fire Extinguisher (Dry Chemical Type)**

The dry chemical type fire extinguisher is effective in areas where ambient temperature is  $-25^{\circ}\text{F}$ . and above. If winterized (pressurized with nitrogen), the fire extinguisher may be used in temperatures below  $-25^{\circ}\text{F}$ . The fire extinguisher is a 2½ pound, stored-pressure, lever-operated extinguisher.

### **2.23. Operating Extinguisher**

*a.* Disconnect the clamp that secures the extinguisher to its mounting bracket. Swing the clamp open, and remove the extinguisher.

*b.* Hold the extinguisher upright and raise the large locking handle to break the seal.

*c.* Aim the nozzle at the base of the fire and depress the small operating lever with the thumb.

*d.* Direct the discharge at the base of the fire with a side to side sweeping motion.

### **2-24. Maintenance**

Weigh the fire extinguisher every 6 months. Replace the extinguisher if the weight is less than 4½ pounds, or the pressure is below 125 pounds. The dry chemical type fire extinguisher will be serviced at installation level through Repair and Utilities facilities, with the filling agent supplied by local procurement through Troop Supply Channels. Refer to TB 5-4200-200-

~~100~~  
100 See ch 3



**Section I. BASIC ISSUE ITEMS**

**3-1. General**

Tools, equipment, and repair parts issued with or

authorized for the tractor are listed in the basic issue items list, appendix C.

**Section II. LUBRICATION INSTRUCTIONS**

**3-2. General**

Periodic lubrication of the tractor is the responsibility of organizational maintenance, and detailed lubrication information is contained in the lubrication order, L O 10-3930-626-12. This section contains information on lubrication which is the responsibility of the operator. This lubrication must be performed as conditions require.

**3-3. Detailed Lubrication Instructions**

*a. General.* Keep all lubricants in closed containers and store in a clean, dry place away from external heat. Allow no dust, dirt, or other foreign material to mix with the lubricants. Keep all lubricating equipment clean and ready to use.

*b. Cleaning.* Keep all external parts adjacent to lubricating points clean and free of lubricant. Before adding lubricant, wipe lubricating points free of dirt and grease. Use care to prevent foreign matter from entering lubrication points while cleaning and adding lubricant. After adding lubricant, clean away any spilled lubricant, again taking care to prevent foreign matter from entering at lubrication point.

*c. Points of Lubrication.* The points of lubrication for which the operator is responsible during day to day operation are shown in figure 3-1. These points are limited to the engine crankcase and the transmission and torque converter.

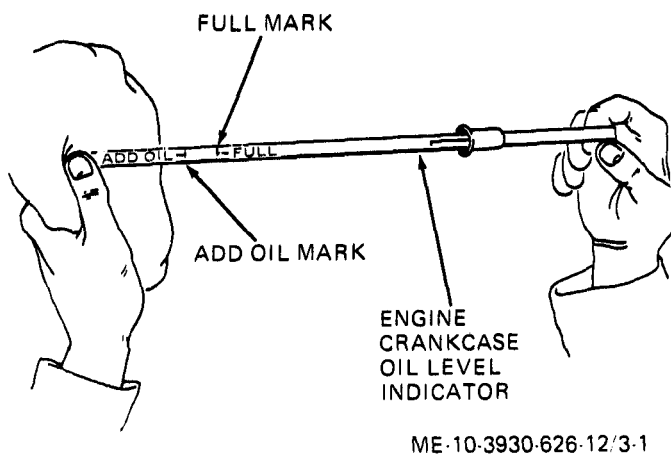
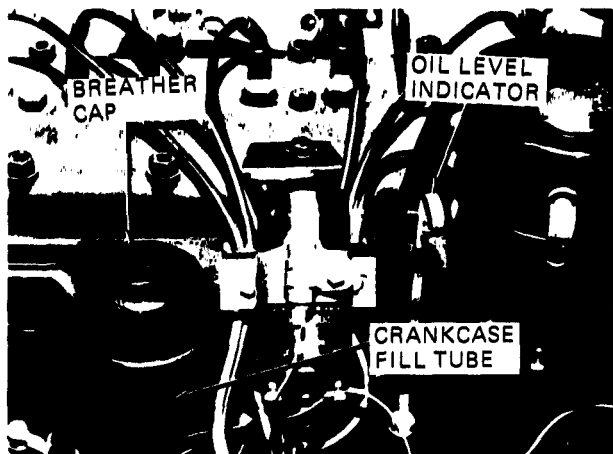
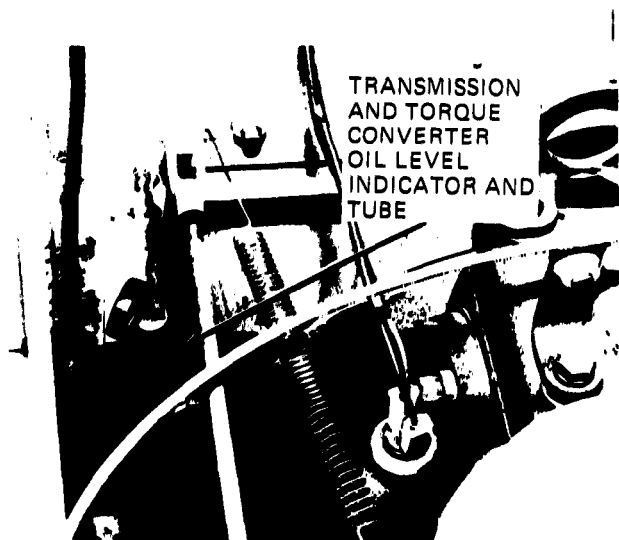

d. *Checking Crankcase Oil Level and Adding Oil.* Before daily startup, check the crankcase oil level and add oil if required as follows:

- (1) Pullout the oil level indicator (fig. 3-1) and wipe with a clean cloth.
- (2) Reinsert oil level indicator firmly.
- (3) Pull out oil level indicator, and read oil level.

*Note.* The FULL mark on the oil level indicator shows the proper level after the engine has been standing idle for a few hours. For an engine that has been running recently, the level will normally be slightly lower. This is due to oil filling the oil passages and filter. This oil will drain back into the crankcase as the engine stands idle. If the oil level is at or below the ADD OIL mark as checked above, add one quart of oil.

- 4) Reinsert the oil level indicator firmly.
- (5) If oil is required, remove the breather cap from the crankcase fill tube, and pour one quart of oil into the crankcase fill tube. Replace breather cap.

**Caution:** Be sure the oil you add is the same grade and weight as that already in the crankcase. If in doubt, check with organizational maintenance personnel.

**Caution:** Do not operate the tractor if the oil level as checked after a few hours of standing idle is below the ADD OIL mark.

~~e. *Checking Transmission and Torque Converter Oil Level and Adding Oil.* After daily initial startup, check oil level in transmission and torque converter, and add oil if necessary as follows:~~

~~(1) Allow engine to run at idle speed with transmission shift lever in N (neutral) position for at least four minutes.~~

~~(2) Set parking brake and shift transmission shift lever through all positions two or three times. Return shift lever to N position.~~

~~(3) With engine still idling, pull out the transmission oil level indicator, and wipe with a clean cloth.~~

~~(4) Reinsert oil level indicator firmly.~~

~~(5) Pull out oil level indicator, and read oil level.~~

~~(6) If oil level is below the FULL mark, add oil (OE10) by pouring through oil level indicator tube. Add just enough to bring the level up to the FULL mark.~~

~~(7) Reinsert oil level indicator firmly.~~

*Reinsert oil level indicator - See Ch. 3*

Figure 3-1. Operator's daily service lubrication points.

## Section III. PREVENTIVE MAINTENANCE CHECKS AND SERVICES

### 3-4. General

To insure that the tractor is ready for operation at all times, it must be inspected systematically so that defects may be discovered and corrected before they result in serious damage or failure. The necessary preventive maintenance checks and services to be performed are listed and described in paragraph 3-5. The item numbers indicate the sequence of minimum inspection requirements. Defects discovered during operation of the unit will be noted for future correction, to be made as soon as operation has ceased. Stop operation immediately if a deficiency is noted during operation which would damage the equipment if operation

were continued. Record all deficiencies and shortcomings together with the corrective action taken on DA Form 2404 (Equipment Inspection and Maintenance Worksheet) at the earliest possible opportunity.

### 3-5. Preventive Maintenance Checks and Services

Table 3-1 contains a tabulated listing of the operator's periodic (daily and weekly) preventive maintenance checks and services. The item numbers are listed consecutively and indicate the sequence of minimum requirements.

*Table 3-1. Preventive Maintenance Checks and Services*

Operator's Maintenance Category			Daily Schedule (or weekly)		
Interval and sequence number			Item to be inspected	Procedure	Paragraph reference
Before operation	During operation	After operation			
1			Radiator	Remove radiator cap and check coolant level; add coolant if required.	para 3-11b
2			Engine Crankcase	Check oil level; add oil if required.	para 3-3d
*3			Air cleaner	Clean.	para 3-12
4			Battery	Check electrolyte level; add water if required; recharge.	para 3-15
5			Transmission	Check oil level; add oil if required.	para 3-3e
*6			Tires and tubes	Check inflation pressure; increase or decrease pressure if required.	para 3-14
	1		Fuel tank	Add fuel as required	para 3-13
		**1	Radiator	Drain, clean, and refill.	para 3-11e

*Augmented as per Jace Ch. 3*

\* To be accomplished weekly instead of daily  
 \*\* To be accomplished annually

## Section IV. OPERATOR'S TROUBLESHOOTING

### 3-6. General Observation of Tractor Operation

You should always be alert for improper operation of the tractor. You will not be able to correct any major trouble since parts and tools are not authorized at the operator level. Observe the trouble carefully so that you can give an accurate report to organizational maintenance personnel. This will save time and effort in getting your tractor back into good running condition.

### 3-7. Operator's Troubleshooting

Chart 3-1 contains information that will be useful to you in troubleshooting. Malfunctions and corrective actions which are beyond the scope authorized for the operator are not included in the chart. If the trouble cannot be corrected by applying the "corrective action", report the trouble to organizational maintenance personnel.

Chart 3-1. operator's Troubleshooting

Malfunction	Probable Cause	Corrective Action
1. Engine will not crank. 2. Engine cranks but will not start.	Battery electrolyte level low. a. Improper starting procedure.	Service battery ( para 3-15 b) a. Check and follow operating procedure (para 2-11). b. Fill fuel tank.
3. Engine overheats.	b. Out of fuel. a. Obstruction in front of radiator. b. Coolant level low. c. Oil level low.	a. Remove obstruction. (para 3-11 a) b. Service radiator (para 3-11 b) c. Service engine crank case (para 3-3(d))
4. Tractor will not move in forward or reverse.	Transmission oil level low.	Service transmission (para 3-3 e)
5. Transmission overheats.	Tractor being overloaded or improperly operated.	Reduce loads. Operate according to instructions (para 2-12, 2-15 thru 2-21).
6. Engine lacks power under load. 7. Difficult steering.	Clogged air cleaner. Tires under inflated.	Service air cleaner (para 3-12 b). Service tires (para 3-14).

## Section V. OPERATOR'S MAINTENANCE OF TRACTOR

### 3-8. General

The following paragraphs describe the responsibilities of the operator in maintaining the tractor. These responsibilities are limited to servicing the following:

- a. *Engine.* Refer to paragraph 3-9.
- b. *Transmission.* Refer to paragraph 3-10.
- c. *Radiator.* Refer to paragraph 3-11.
- d. *Air Cleaner.* Refer to paragraph 3-12.
- e. *Fuel Tank.* Refer to paragraph 3-13.
- f. *Tires and Tubes.* Refer to paragraph 3-14.
- g. *Battery.* Refer to paragraph 3-15.

### 3-9. Engine

a. *Cleaning.* Insure that the engine compartment of the tractor is kept free of foreign objects and materials. As often as conditions may require, wipe off ignition cables, distributor cap, and porcelain insulators of spark plugs with a clean cloth. Dust on these parts can attract moisture which will result in difficult starting and poor performance. Clean away lubricants as described in paragraph 3-3 b.

b. *Lubrication.* Check crankcase oil level daily (more often under severe operating conditions). Add lubricating oil as required. Refer to paragraph 3-3 d.

### 3-10. Transmission

~~Check oil level in transmission daily (more often under severe operating conditions. Add oil when required. Refer to paragraph 3-3 e.~~

### 3-11. Radiator

**Warning:** When removing radiator cap when cooling system is hot, turn cap very slowly

**counterclockwise to the bleedoff position. When pressure in system has relieved, depress cap and turn counterclockwise to remove. Failure to heed this warning may result in serious personal injury from rapidly escaping coolant. If system is extremely hot, use a rag to hold the radiator cap when removing.**

a. *External Cleaning.* Clean dirt, insects, trash, and other foreign matter from front side of radiator. Use compressed air or a stream of water under low pressure directed from the engine side of the radiator. Clean radiator cap by spraying a stream of water (hot if possible) through holes in valve cage while moving valve up and down with a blunt wood stick.

b. *Adding Coolant.* Check level of coolant daily. Add coolant, if required, using a premixed solution of 50 percent antifreeze conforming to Federal Specification 0-A-548 and 50 percent water. Fill radiator to within one inch of top of filler neck. Replace radiator cap securely.

c. *Draining, Cleaning, and Refilling Radiator.* Drain, clean, and refill the radiator (and cooling system) annually as follows (fig. 3-2):

(1) *Drain system.* Operate engine at a fast idle until normal operating temperature is reached. A fast idle will stir up any loose rust, scale, and other foreign matter in cooling system. Place an obstruction in front of radiator, if required, to bring engine temperature up to at least 180 degrees F. Stop the engine. Remove radiator cap, and open drain cocks in engine block and radiator. Allow cooling system to drain completely.

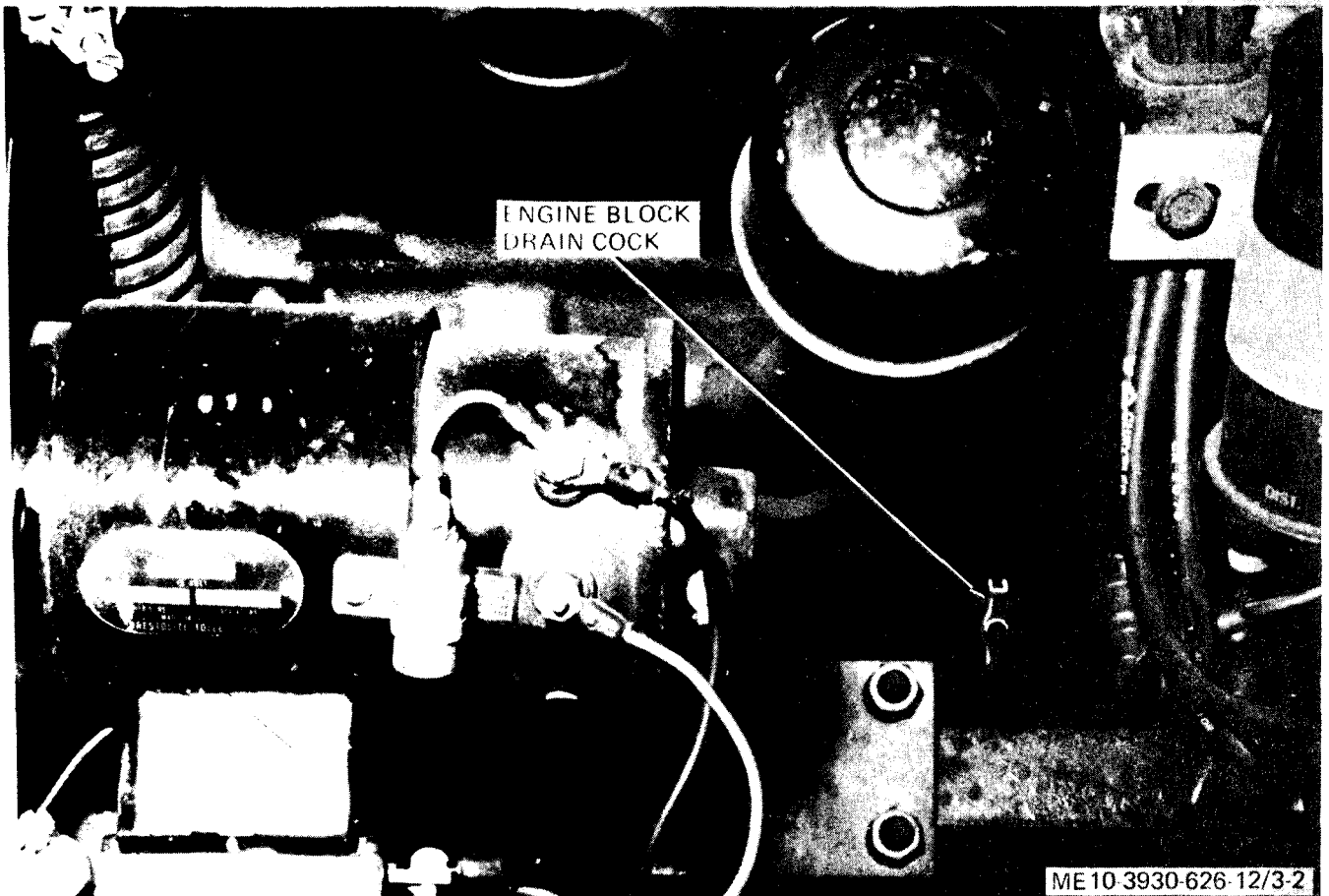
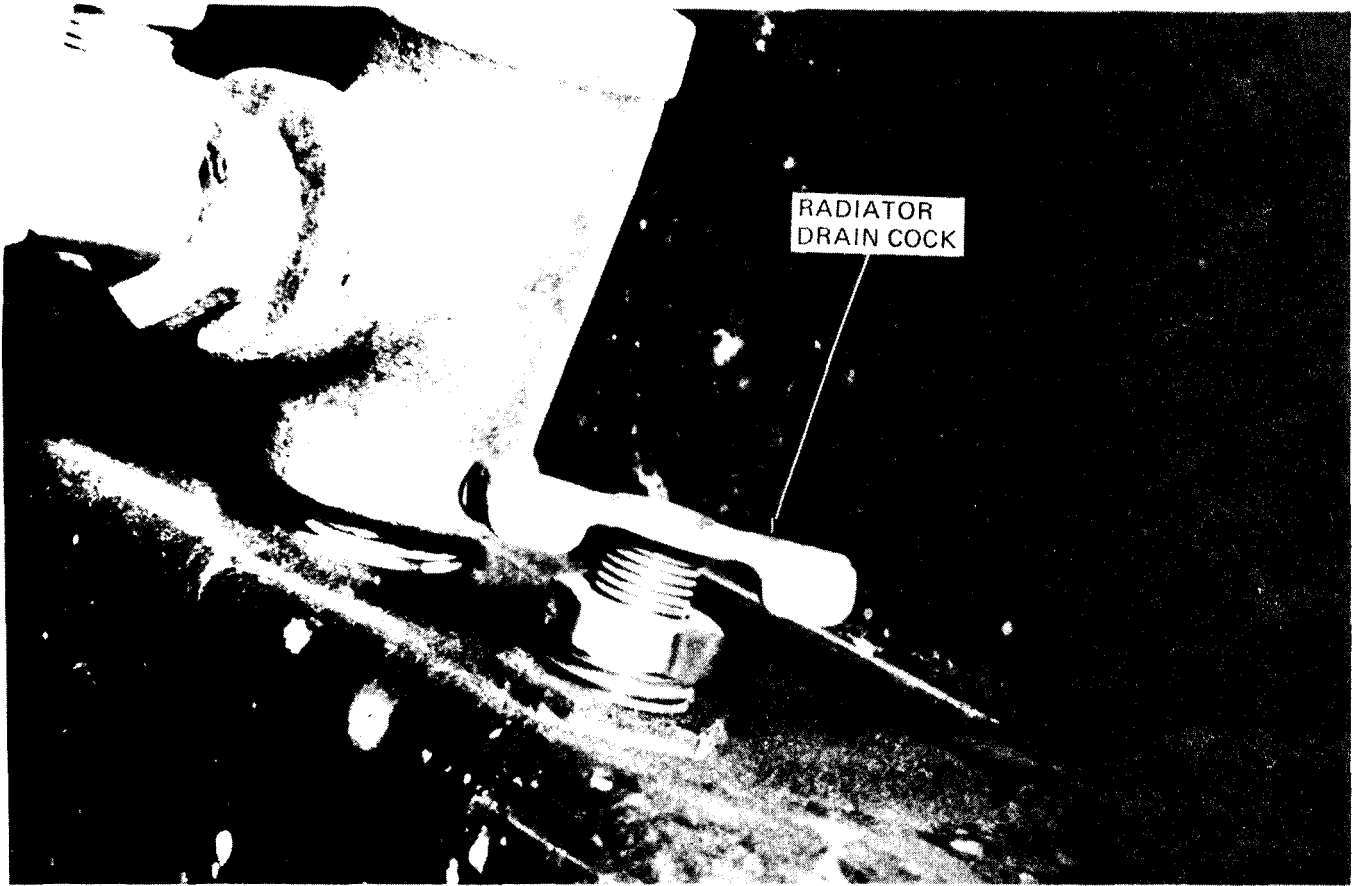

Figure 3-2. Cooling system service points.

**Caution:** Do not pour cold coolant or water into radiator when engine temperature is above 200 degrees F. Cold coolant or water, regardless of engine temperature, will close the thermostat and prevent complete filling of engine water jackets and passages. When filling the system with cold coolant or water, always operate engine until normal operating temperature is reached (thermostat opens); then, add coolant or water as required to fill radiator.

**Warning:** Radiator cleaning compound contains acid. Avoid contact with skin. If contact occurs, wash affected area immediately with baking soda solution or with liberal quantity of water. If cleaning compound splashes into eyes, wash immediately with liberal quantity of water and obtain medical aid as quickly as possible.

(2) *Clean system.* Close drain cocks on engine block and radiator. Pour cleaning compound conforming to specification MIL-C-10597B (ORD) into radiator. Fill radiator with water, and install radiator cap. Start engine and operate at fast idle until temperature reaches at least 150 degrees F. Allow engine to operate at least 30 minutes. Stop engine. Remove radiator cap, and open drain cocks on radiator and engine block. Allow system to drain completely.

**Caution:** Be sure after using cleaning compound to flush cooling system thoroughly as described below. Cleaning compound contains a strong acid which if not completely flushed away may attack parts of the cooling system. Do not attempt to flush the system by inserting a hose into the radiator with the drain cocks open and the engine running. This procedure will cause the thermostat to close and stop circulation of water through the engine.

(3) *Flush system.* Close drain cocks on radiator and engine block. Fill cooling system with clean fresh water, and install radiator cap. Start

engine, and operate at fast idle until temperature reaches at least 180 degrees F. Continue to operate engine for at least five minutes. Stop engine. Remove radiator cap, and open drain cocks on radiator and engine block. Allow system to drain completely. If water is discolored to any extent, repeat the flushing operation.

(4) *Fill system.* Close drain cocks on radiator and engine block. Pour coolant (consisting of a premixed solution of 50 percent antifreeze conforming to Federal Specification O-A-548 and 50 percent water) into radiator. Install radiator cap. Start engine, and allow to operate at fast idle until temperature gage shows normal operating temperature. Stop engine. Remove radiator cap and check coolant level in radiator. If necessary, add coolant until level is approximately one inch below top of radiator filler neck. Reinstall radiator cap.

### 3-12. Air Cleaner

a. *General.* Clean the air cleaner element after every 75 hours of tractor operation under normal conditions. When operating under very dusty or sandy conditions, clean the element daily.

b. *Removing, Cleaning, and Reinstalling Air Cleaner Element.*

(1) Remove wing nut and cover plate from front of air cleaner (fig. 3-3).

(2) Withdraw element from body of air cleaner.

(3) Tap element lightly on floor or bench, being careful not to deform the element. Blow dust from plated element with compressed air under light pressure.

**Caution:** Do not direct high pressure air steam at element. Do not wet the element for cleaning or for any other reason.

(4) Reinstall element on air cleaner body with cover plate and wing nut. Tighten wing nut firmly.

Note. Obtain and install a new filter element after every 800 hours of tractor operation.



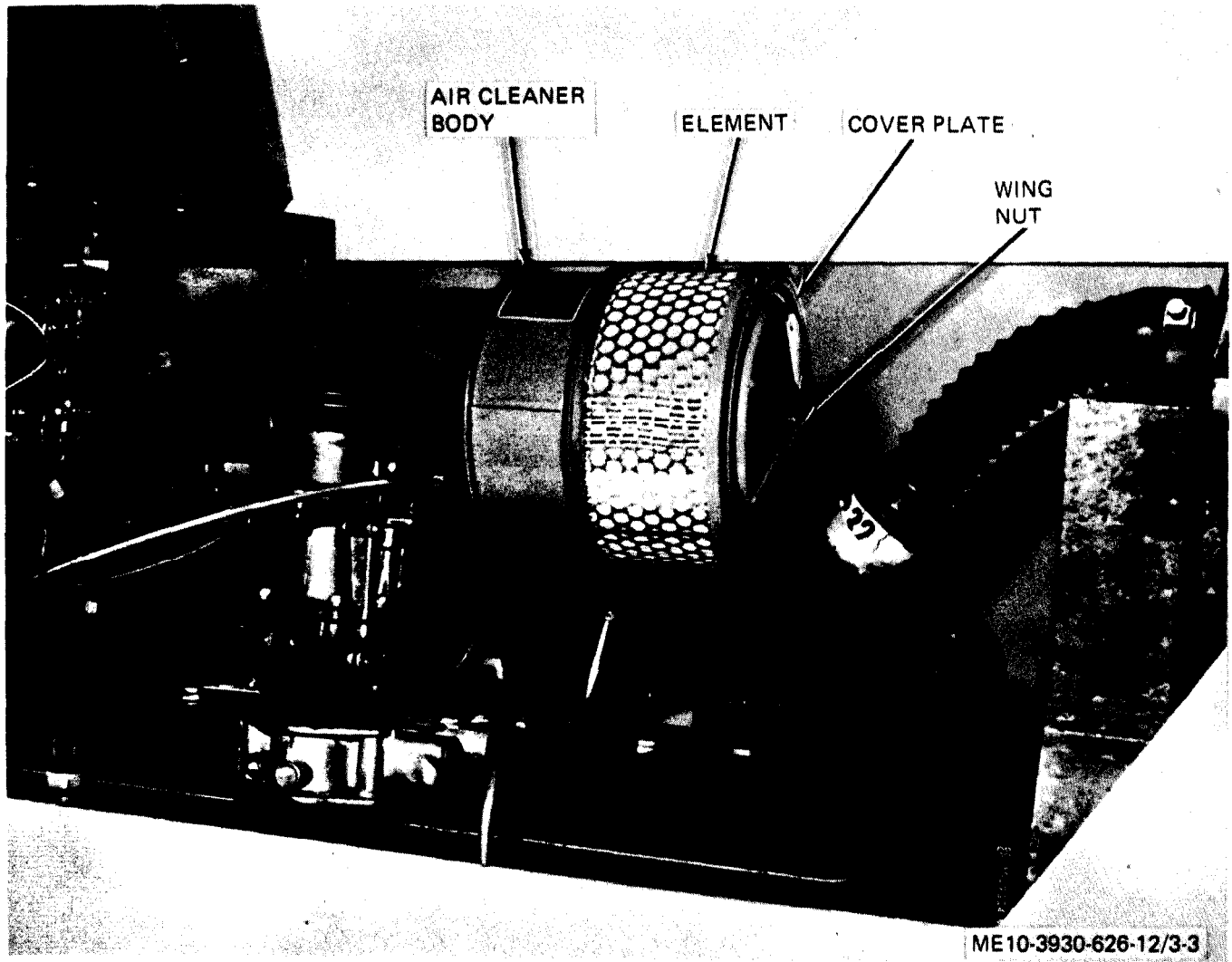

Figure 3-3. Servicing air cleaner.

### 3-13. Fuel Tank

Service fuel tank by filling with gasoline to meet operating requirement. During cold or extremely humid weather, keep the tank filled to as near capacity as practical to prevent condensation of moisture in tank.

### 3-14. Tires and Tubes

Inspect tires weekly for cuts, wear, sidewall damage, and imbedded foreign objects such as glass

or stones. Remove foreign objects, Report damage affecting serviceability of tires to proper authority. Check inflation pressure of all tires. Increase or decrease pressure as required. Proper inflation of front and rear tires is 45 psig.

### 3-15. Battery

a. *General.* Battery service consists of adding water to battery, keeping battery terminals clean, and recharging battery when required (fig. 3-4).

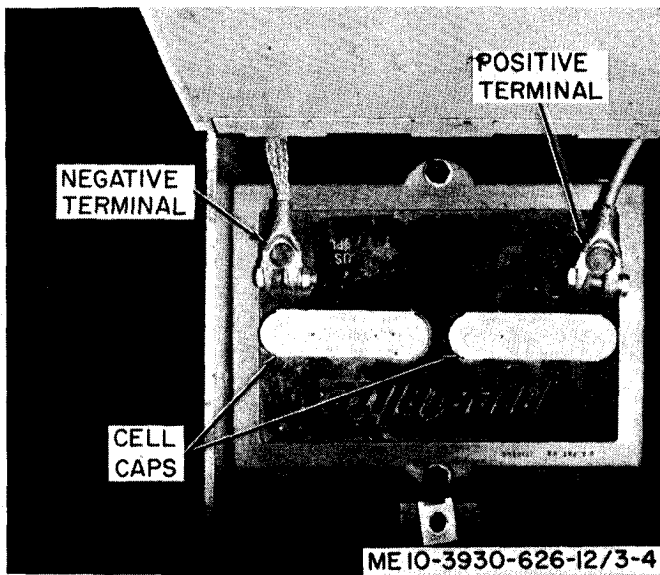

Figure 3-4. Servicing battery.

b. *Adding Water to Battery.* Check level of electrolyte in battery daily by removing cell caps and observing level. Electrolyte should cover the plates. If level is low, add just enough distilled water to cover plates. Do not add electrolyte when level is low. Replace cell caps.

c. *Cleaning Battery Terminals.* When checking electrolyte level in battery, observe positive and negative terminals for buildup of corrosion and for presence of electrolyte on top of battery case. If corrosion or electrolyte is present, wash away with a mixture of baking soda and water. A toothbrush or other small brush is recommended for scrubbing terminals and connectors on cables. Rinse with

clean water and dry with cloth. To prevent further corrosion, coat battery terminals and cable connectors with petroleum jelly or heavy grease.

**Caution:** When cleaning battery case or battery terminals, be sure cell caps are in place and take other necessary precautions to prevent cleaning solution from entering battery cells.

d. *Recharging Battery.* Routine or periodic recharging of the battery will not be necessary under normal conditions. If battery requires frequent recharging, a malfunction is present in the electrical system. Report the condition to proper authority. The battery will require recharging if the headlights have been left on while the tractor is idle or if the battery has been severely discharged while trying to start the engine. In most cases, if a booster battery has been used to start the engine, the discharged battery in the tractor will be successively recharged during normal operation of the tractor. Be sure to keep the battery fully charged during extremely cold weather since the electrolyte in a partially discharged battery is likely to freeze. If any doubt exists about battery condition, check the specific gravity of the electrolyte with a hydrometer. When using a hydrometer hold the barrel vertical with sufficient electrolyte in the barrel to lift the float. Take the reading at eye level. Disregard the curvature of the electrolyte at the point of contact with the float. The following chart relates hydrometer readings to battery condition.

Fully charged	1.275 to 1.300
Half charged	1.220 to 1.225
Low charge	1.160 to 1.170
Dangerously low	1.150 or below

## ORGANIZATIONAL MAINTENANCE

## Section I. SERVICE UPON RECEIPT OF TRACTOR

**4-1. General**

When a new or used tractor is received by a using organization, it must be serviced before operation is attempted. Servicing for new tractor is described in paragraphs 2-3 and 2-4. The procedures may have to be modified for used tractors if different levels of preservation packing have been used.

**4-2. Responsibilities**

Many of the items requiring servicing must be performed by organizational personnel having the proper tools. Other items which do not require tools may be performed by the assigned operator if directed to do so by the commanding officer.

## Section II. REPAIR PARTS, SPECIAL TOOLS, AND EQUIPMENT

**4-3. Tools and Equipment**

Tools, equipment, and repair parts issued with or authorized for the tractor are listed in the basic issue items list, appendix C.

**4-4. Special Tools and Equipment**

No special tools or equipment are required at the

organizational maintenance level for the tractor.

**4-5. Maintenance Repair Parts**

Repair parts and equipment are listed and illustrated in the repair parts and special tools list covering organizational maintenance for this equipment. Refer to TM 10-3930-626-20P.

## Section III. LUBRICATION INSTRUCTIONS

**4-6. General**

This section contains lubrication instructions which are supplemental to and not specifically covered in the lubrication order for the tractor. For current lubrication order refer to LO 10-3930-626-12.

**4-7. Care of Lubricants**

Refer to paragraph 3-3a for proper care of lubricants.

**4-8. Cleaning Lubrication Points**

Refer to paragraph 3-3b for cleaning lubrication points.

**4-9. Lubricating Front Wheel Bearings**

The front wheels and wheel hubs must be removed when lubricating front wheel bearings. Refer to paragraph 4-60 for removal procedure. Handle bearing (cups, and cones and rollers) carefully to prevent damage. Do not spin bearings before cleaning. Wash all bearing parts with SD (solvent, dry-cleaning), and dry with compressed air under moderate pressure. Pack cones and rollers thoroughly with grease and apply grease liberally to

bearing cups. Refer to paragraph 4-60 for reassembly instructions. *(Added) see ch 3*

**4-10. Access to Rear Drag Link and Steering Gear and Brake Shaft**

For access to the rear drag link, steering gear and brake shaft for lubricating, remove the floor plates from the tractor chassis as follows:

a. Remove cotter pin and washer from end of accelerator pedal rod, and disengage rod from pedal.

b. Unscrew pedal pad from brake pedal rod. Remove pedal pad and lock washer.

c. Remove hexagon head cap screws which secure floor plates to chassis.

d. Slide floor plates off chassis.

e. After lubricating, reinstall floor plates by reversing the above procedure.

**4-11. Access to Brake Master Cylinder**

For access to the master cylinder, pry out the plug button located on the plate adjacent to the transmission shift lever. Be sure to replace the button after servicing master cylinder.

*4-11.1 Transmission (Added) See ch 3*

**Section IV. PREVENTIVE MAINTENANCE CHECKS AND SERVICES**

**4-12. General**

This section lists the quarterly preventive maintenance requirements for the tractor. By following the preventive maintenance services, the tractor can be maintained in good operating condition. When performing the services, be alert to discover any defects which must be referred to higher maintenance levels for correction.

**4-13. Quarterly Preventive Maintenance Check and Services**

The quarterly preventive maintenance checks and services are listed in table 4-1. A quarterly interval is equal to three calendar months or 250 hours of operation (as shown on the tractor hour meter), whichever occurs first. The Sequence numbers in the Table indicate the sequence for performing the checks and services.

Table 4-1. Preventive Checks and Services

Sequence number	Item to be inspected	Procedures	Paragraph reference
1	Fan belt	Inspect for worn, frayed, or cracked condition. Replace belt if worn, cracked or frayed. Check for proper tension (1/2 inch deflection midway between generator pulley and fan pulley). Adjust tension if required.	para 4-28 b (4)
2	Radiator and radiator hoses	Check radiator for leaks and for damaged cooling fins. Replace radiator if leaking or damaged. Check radiator hoses for cracks or other deterioration. Replace hoses if cracked or deteriorated. Check security of radiator hose clamps. Tighten if loose; replace if broken or damaged.	para 4-28 b (5) and 4-28 d. para 4-33 para 4-31 para 4-31
3	Water pump	Inspect for leakage at shaft seal and at gasket where pump mounts to engine block. Replace pump if leaking at seal or replace pump gasket if leaking.	para 4-28
4	Spark plugs	Remove, inspect, clean, regap, and replace.	para 4-29
5	Manifolds	Check for exhaust fume leakage at gaskets between manifold and engine block. Replace gaskets if leakage is observed.	para 4-27
6	Valves	Check for noisy operation with engine running at normal temperature. Check and adjust valve lash.	para 4-26
7	PCV valve	Remove, clean, and replace. <i>if nec</i>	para 4-20
8	Fuel filter	Remove, clean, and replace. <i>if nec</i>	para 4-37
9	Battery and battery cables	Inspect for security of battery fold down and tighten nuts, if required. Check that battery cable clamps are tight, and that cables are in good condition. Replace cables if damaged or deteriorated.	para 4-51 para 4-51
10	Handbrake cable and lever	Check operation. Adjust if necessary	para 4-55 a, b.
11	Service brakes	Check operation. Adjust if necessary	para 4-56 a
12	Steering	Check for looseness. Adjust if necessary	para 4-65 e, and 4-66 e
13	Exhaust	Check for leaking of exhaust fumes and exhaust noise. Replace muffler and / or pipe if leaking or noisy.	para 4-44
14	Starting motor	Check for proper operation. Replace if necessary.	para 4-48

See ch 3

## Section V. TROUBLESHOOTING

### 4-14. General

When performing organizational maintenance on the tractor, always be alert for unusual noises or vibrations while the tractor is in operation. Many repairs cannot be performed at organizational maintenance level since tools and parts are not authorized at that level. Observe troubles carefully so that you can give an accurate report to higher maintenance. This will save time and trouble in getting the tractor back into service.

### 4-15. Troubleshooting at Organizational Maintenance Level

Chart 4-1 contains information that will be helpful in troubleshooting at the organizational level. Malfunctions and corrective actions which are beyond the scope of organizational maintenance are not included in the chart. If the trouble cannot be corrected by applying the "corrective action", report the trouble to a higher maintenance level.

*Chart 4-1. Organizational Maintenance Troubleshooting*

Malfunction	Probable Cause	Corrective Action
1. Engine idles rough but is satisfactory under load.	<ul style="list-style-type: none"> <li>a. Improper carburetor idle adjustment.</li> <li>b. Intake system air leak.</li> <li>c. Spark plug gap too small.</li> <li>d. Leaking carburetor needle valve.</li> </ul>	<ul style="list-style-type: none"> <li>a. Adjust carburetor idle ( para 4-36 a )</li> <li>b. Check with vacuum gage (para 4-24).</li> <li>c. Regap spark plugs (para 4-29).</li> <li>d. Replace carburetor ( para 4-36 ).</li> </ul>
2. Engine rough under load but idles satisfactorily.	<ul style="list-style-type: none"> <li>a. Insulation breakdown in coil, or spark plug wires.</li> <li>b. Defective capacitor</li> <li>c. Fouled spark plug(s)</li> </ul>	<ul style="list-style-type: none"> <li>a. Replace coil or spark plug wires (para 4-50 or 4-17 g )</li> <li>b. Replace capacitor (para. 4-49c).</li> <li>c. Clean or replace spark plug(s) (para 4-29).</li> </ul>
3. Engine idles poorly, is rough under load, may backfire.	<ul style="list-style-type: none"> <li>a. Plug wires to wrong plugs or exchanged in cap.</li> <li>b. Valves improperly adjusted.</li> </ul>	<ul style="list-style-type: none"> <li>a. Install plug wires correctly ( para 4-17 g ).</li> <li>b. Adjust valves (para 4-26 b ).</li> </ul>
4. Engine lacks power under load.	<ul style="list-style-type: none"> <li>a. Defective ignition points.</li> <li>b. Ignition timing improperly adjusted.</li> </ul>	<ul style="list-style-type: none"> <li>a. Clean or replace ignition points (para 4-49 c ).</li> <li>b. Adjust ignition timing ( para 4-49 d ).</li> </ul>
5. Excessive fuel consumption.	<ul style="list-style-type: none"> <li>a. Carburetor improperly adjusted.</li> <li>b. Engine running at too low temperature.</li> </ul>	<ul style="list-style-type: none"> <li>a. Adjust carburetor ( para 4-36 a ).</li> <li>b. Replace thermostat (para 4-32).</li> </ul>
6. Engine overheats.	<ul style="list-style-type: none"> <li>a. Slipping or broken fan belt.</li> <li>b. Late ignition timing.</li> <li>c. Defective thermostat.</li> </ul>	<ul style="list-style-type: none"> <li>a. Adjust fan belt tension or replace fan belt (para 4-28).</li> <li>b. Adjust ignition timing ( para 4-49 d ).</li> <li>c. Replace thermostat (para 4-32).</li> </ul>
7. Engine cranks slowly, starts hard, battery charged.	<ul style="list-style-type: none"> <li>a. Loose or corroded battery cables or terminals.</li> <li>b. Defective starter.</li> </ul>	<ul style="list-style-type: none"> <li>a. Tighten or replace cables as required (para 4-51 ).</li> <li>b. Replace starter (para 4-48).</li> </ul>
8. Engine cranks for short period, starts hard, battery runs down quickly.	<ul style="list-style-type: none"> <li>a. Defective battery.</li> <li>b. Defective starter.</li> </ul>	<ul style="list-style-type: none"> <li>a. Replace battery (para 4-51).</li> <li>b. Replace starter (para 4-48).</li> </ul>
9. Battery does not	<ul style="list-style-type: none"> <li>a. Loose fan belt.</li> <li>b. Voltage regulator improperly adjusted.</li> <li>c. Defective generator regulator.</li> <li>d. Defective generator.</li> </ul>	<ul style="list-style-type: none"> <li>a. Replace fan belt (para 4-28 a ).</li> <li>b. Adjust voltage regulator ( para. 4-47 d ).</li> <li>c. Replace generator regulator ( para 4-47 b and c ).</li> <li>d. Replace generator (para 4-46 b and c ).</li> </ul>
10. Engine starts but stops or loses power when warmed up.	<ul style="list-style-type: none"> <li>a. Incorrect valve adjustment.</li> <li>b. Defective ignition coil.</li> </ul>	<ul style="list-style-type: none"> <li>a. Adjust valves ( para 4-27 b ).</li> <li>b. Replace ignition coil (para 4-50).</li> </ul>
11. Propeller shaft noise, vibration, or backlash.	<ul style="list-style-type: none"> <li>a. Loose propeller shaft.</li> <li>b. Worn universal joints.</li> </ul>	<ul style="list-style-type: none"> <li>a. Tighten propeller shaft mounting bolts (para 4-53).</li> <li>b. Replace universal joints (para 4-53).</li> </ul>
12. Excessive play or looseness in steering.	<ul style="list-style-type: none"> <li>a. Loose or worn drag link.</li> <li>b. Loose or worn tie rod.</li> </ul>	<ul style="list-style-type: none"> <li>a. Adjust or replace drag link (para 4-65)</li> <li>b. Adjust or replace tie rod ( para 4-66).</li> </ul>

Chart 4-1. Organizational Maintenance Troubleshooting—Continued

Malfunction	Probable Cause	Corrective Action
13. One wheel brake seizes on light pedal application.	a. Brake fluid or other foreign matter on brake lining. b. Defective brake cylinder.	a. Repair brakes (para 4-56). b. Repair brakes (para 4-56).
14. Service brakes will not hold.	a. Brakes out of adjustment. b. Defective master cylinder.	a. Adjust brakes (para 4-56 a). b. Replace master cylinder (para 4-57).
15. Service brakes drag.	a. Improper adjustment of brake pedal. b. Defective master cylinder.	a. Adjust brake pedal (para 4-58). b. Replace master cylinder (para 4-57).
16. Brake pedal fails or fades under pressure.	a. Air trapped in brake lines. b. Defective master cylinder.	a. Bleed brake system (para 4-57 d). b. Replace master cylinder (para 4-57).
17. Spongy pedal feel.	Air trapped in brake lines.	Bleed brake system ( para 4-57 d ).
18. Service brake will not release.	a. Improper brake pedal adjustment. b. Defective master cylinder.	a. Adjust brake pedal (para 4-58). b. Replace master cylinder (para 4-57).
19. Pedal travel excessive for braking action.	a. Improper brake shoe adjustment. b. Brake pedal improperly adjusted.	a. Adjust brakes (para 4-56 b). b. Adjust brake pedal (para 4-58).
20. Parking (hand ) brake will not hold on incline.	a. Handbrake lever improperly adjusted. b. Defective handbrake lever or cable. c. Defective brake.	a. Adjust handbrake lever (para 4-55 a). b. Replace handbrake lever or cable. (para 4-55). c. Repair brake (para 4-55 b).
21. Hand brake lever will not lock in upright position.	a. Broken hand brake cable. b. Handbrake lever improperly adjusted.	a. Replace handbrake cable (para 4-55). b. Adjust handbrake lever (para 4-55 a).
22. Tractor causes radio interference.	Defective radio interference suppression component.	Remove, check, and replace radio interference suppression components (para 4-17 and 4-18).

## Section VI. RADIO INTERFERENCE SUPPRESSION

### 4-16. General Methods Used to Attain Suppression

Essentially, suppression is attained by providing a low resistance path to ground for stray currents. The methods used including special type (carbon core) ignition (spark plug) wires, ignition suppression, (located in lead between coil and distributor) and capacitors.

### 4-17. Replacement of Suppression Components

a. *General.* Suppression components are illustrated in figure 4-1. The following subparagraphs describe replacement of each component.

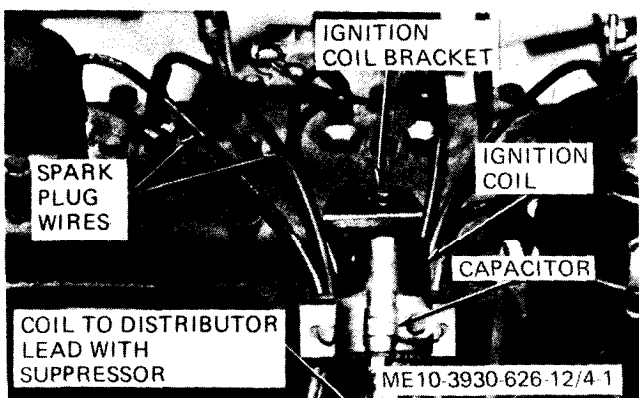
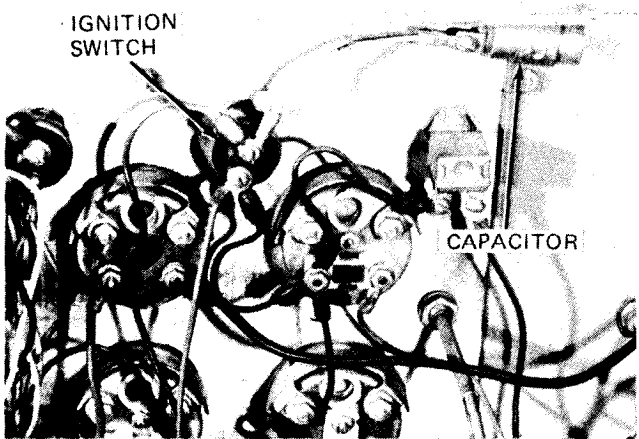
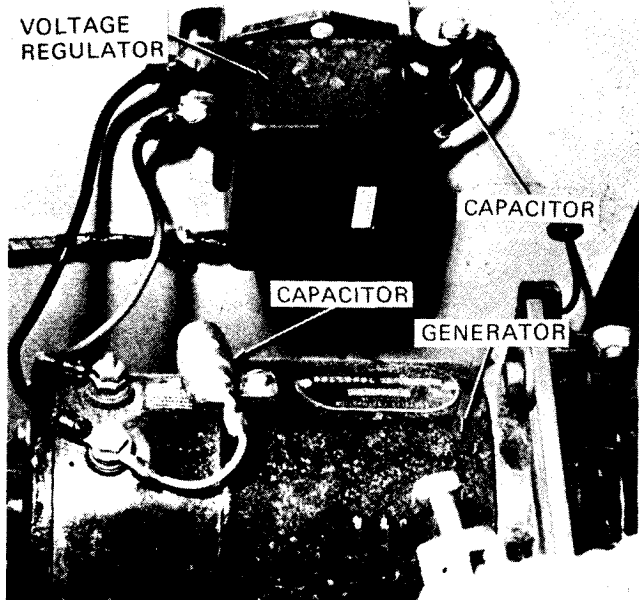

Figure 4-1. Radio interference suppression components.

b. *Generator Capacitor.* Remove screw which secures lead to capacitor terminal and remove screw and lock washer which secure capacitor to generator frame. To install capacitor, reverse the removal procedure.

c. *Regulator Capacitor.* Remove screw which secures lead to capacitor terminal, and remove screw and self-locking nut used to mount capacitor. Withdraw capacitor. To install capacitor, reverse the removal procedure.

d. *Ignition Coil Capacitor.* Remove screw which secures lead to terminal, and remove cap screw, nut and lock washer which secure capacitor to coil mounting strap. To replace capacitor, reverse the removal procedure.

e. *Ignition Switch Capacitor.* Remove screw which secures lead to capacitor terminal. Remove self-locking nut securing capacitor to tractor chassis. Withdraw capacitor. To replace capacitor, reverse the removal procedure.

f. *Coil to Distributor Lead.* Grasp coil to distributor lead firmly near coil, and pull lead free from coil. Grasp lead firmly near distributor cap, and pull lead free from cap. To install new lead, reverse the removal procedure. Assure that nipples (boots) on ends of lead form a good dust-tight seal with coil and distributor cap.

g. *Spark Plug Wires.* Replace wires one at a time to avoid wrong connections between distributor cap and spark plugs. Grasp each wire firmly at distributor cap, and pull wire free from cap. Remove nipple (boot) from free end of wire. Pull wire free from slot in ignition coil bracket. Grasp wire firmly at spark plug terminal end, and pull free from spark plug. To install wires, reverse the removal procedure. Check that nipples (boots) on wires at distributor cap form tight seals.

#### 4-18. Testing Suppression Capacitors

Each of the suppression capacitors has a capacitance rating of 0.10 uf. Use a capacitor tester to check each capacitor after removal from tractor.

**Section VII. MAINTENANCE OF POSITIVE CRANKCASE  
VENTILATION SYSTEM**

**4-19. General**

The positive crankcase ventilation valve (PCV valve) is located on the right side of the engine below the intake manifold (fig. 4-2). An elbow connects the valve to the intake manifold and a connecting tube connects the valve to the engine block.

**4-20. Service and Replacement**

a. Disconnect connecting tube (fig. 4-2) from lower end of PCV valve, then unscrew valve from elbow.

b. Disconnect other end of connecting tube at rear of engine block, and remove tube.

c. Thoroughly flush valve in both directions and flush tube with SD (solvent, dry-cleaning, Fed. Spec. P-S-661 ). Shake valve and tube vigorously to remove cleaning solvent.

d. After cleaning, gently shake valve to determine that check is free.

*Note.* Replace PCV valve if check is not free or if valve shows evidence of internal corrosion.

e. Screw valve onto manifold elbow, being sure to observe proper flow direction (engine block to manifold). Tighten securely.

f. Connect tube to fitting at rear of engine block and to lower end of PCV valve. Tighten connections securely.

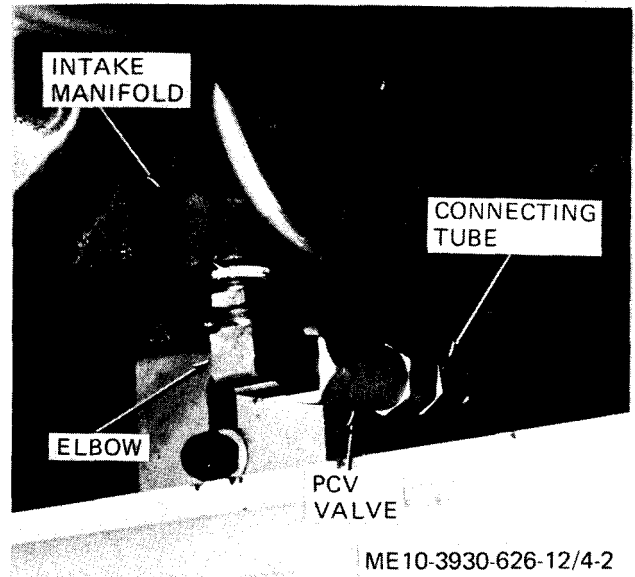

Figure 4-2. Positive crankcase ventilation valve.

**Section VIII. MAINTENANCE OF BASIC ENGINE**

**4-21. General**

a. The engine is a six cylinder L-head unit, with battery ignition. The cooling system includes a front-mounted water pump driven by a V -belt from the crankshaft, a radiator mounted in front of the engine, and a thermostat in the cylinder head water outlet to maintain a constant efficient engine operating temperature. The ignition system consists of a coil, a conventional distributor, resistor spark plugs, the necessary wiring and cabling, and radio interference suppression components. The engine fuel system includes a mechanical fuel pump, a velocity governor, a downdraft singlebore carburetor with air cleaner, and the required fuel lines and manifolding. Cylinder, spark plug and bearing numbering begins at the timing gear, or fan end, of the engine.

b. This section of the manual covers those phases of basic engine maintenance which are the responsibility of organizational maintenance.

**4-22. Compression Test**

a. *General.* Perform a compression test to determine the need of internal repairs before attempting tune-up procedures. This test will indicate

the condition of the piston rings and engine valves. An engine without fairly even compression in all cylinders cannot be properly tuned.

*b. Procedure.*

(1) With shift lever in N (neutral) position, start engine. ~~Start engine.~~ Allow engine to run at fast idle until reaching normal operating temperature.

(2) With engine warmed up, turn off ignition switch and remove spark plug wires from spark plugs. Remove foreign matter from around spark plugs by blowing out with compressed air. Loosen spark plugs one complete turn. Reinstall spark plug cables, and start and run engine at 1000 rpm for approximately 10 seconds to blow out carbon loosened by spark plug loosening.

*Note.* Blowing out carbon in this manner is important in preventing false compression readings due to chips of carbon lodging under the engine valves.

(3) Turn off ignition switch to stop engine.

(4) Remove coil high tension lead from distributor cap and ground lead to engine block.

(5) Remove spark plug leads from spark plugs, and remove spark plugs from cylinder head.

(6) Fully open carburetor throttle and choke



and block in an open position.

(7) Insert compression tester in spark plug hole (fig. 4.3) using an adapter if necessary.

(8) Turn ignition switch on and depress starter switch to crank engine for at least four compression strokes. A starter ~~remove~~ control cable may be used if available. Note pressure reading on first full stroke as well as on final stroke. See test indications below.

*Note.* All cylinders must be tested the same number of strokes to assure accurate readings.

(9) Proper cranking compression pressure is 110 psi to 140 psi.

(10) If the readings are below normal or uneven, place the equivalent of a tablespoon of OE 30 oil in each cylinder and retest compression.

*Note.* Be certain oil is deposited on piston head,

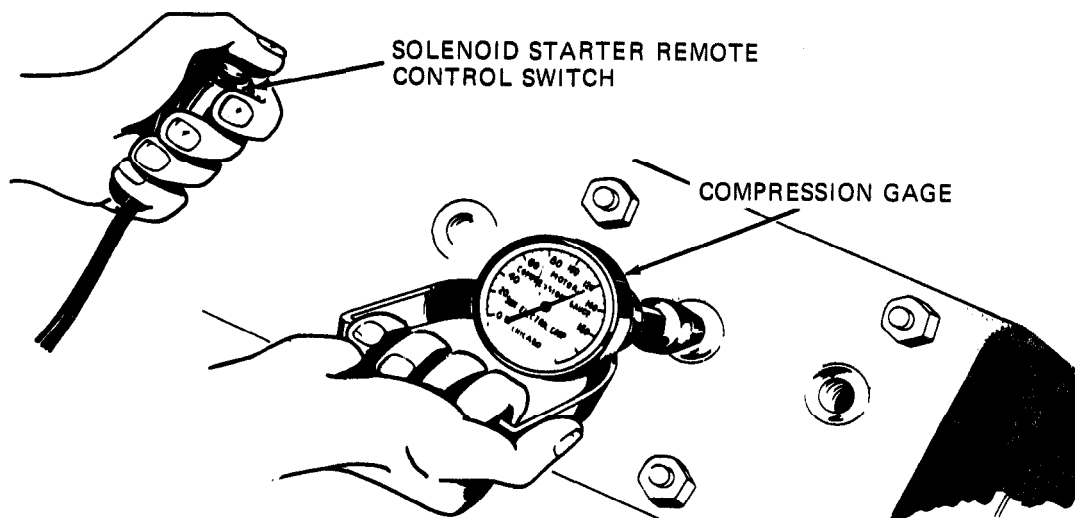

ME 10-3930-626-12/4-3

Figure 4-3. Compression test,

### c. Test Indications.

(1) *Normal.* Compression builds up quickly and evenly to specified compression in each cylinder, varies less than 15 pounds between highest and lowest reading cylinders.

(2) *Ring trouble.* Compression low on first stroke, tends to build up on following strokes but does not reach normal. Improves considerable with addition of oil.

(3) *Valve trouble.* Low on first stroke does not tend to build up on following strokes; does not improve much with addition of oil.

(4) *Leaking head gasket.* Same reaction as valve trouble on two adjacent cylinders, usually accompanied by indications of water in cylinders and / or oil in cylinders.

(5) *Carbon deposits.* Compression pressure considerably higher than specified.

*Note.* After completing compression test, reinstall spark plugs, plug wires and coil to distributor lead. Return choke and throttle controls to normal.

## 4-23. Engine Ignition Timing Test

a. *General.* The purpose of the engine ignition

timing test is to determine the firing point with respect to piston position, and to determine the need for ignition timing adjustment,

### b. Procedure.

(1) Remove spark plug wire from number one ~~or number six~~ spark plug, and install adapter (fig. 4-4) to connect timing light.

**Caution: Use adapter. Do not puncture insulation on spark plug wire to make connection.**

(2) Connect timing light spark plug lead as shown, and power leads to battery terminals.

*Note.* If available equipment requires different power connections, such as connection to a 115 volt source, use appropriate procedures.

(3) Start engine and, at 450 rpm idle speed, direct flashing beam of timing light at top of crankshaft pulley and pointer. If ignition timing is correct, light flash will show scribed mark on crankshaft pulley aligned with pointer on gearcase cover as plug fires. If timing is not correct, refer to paragraph 4-49 e for adjustment.

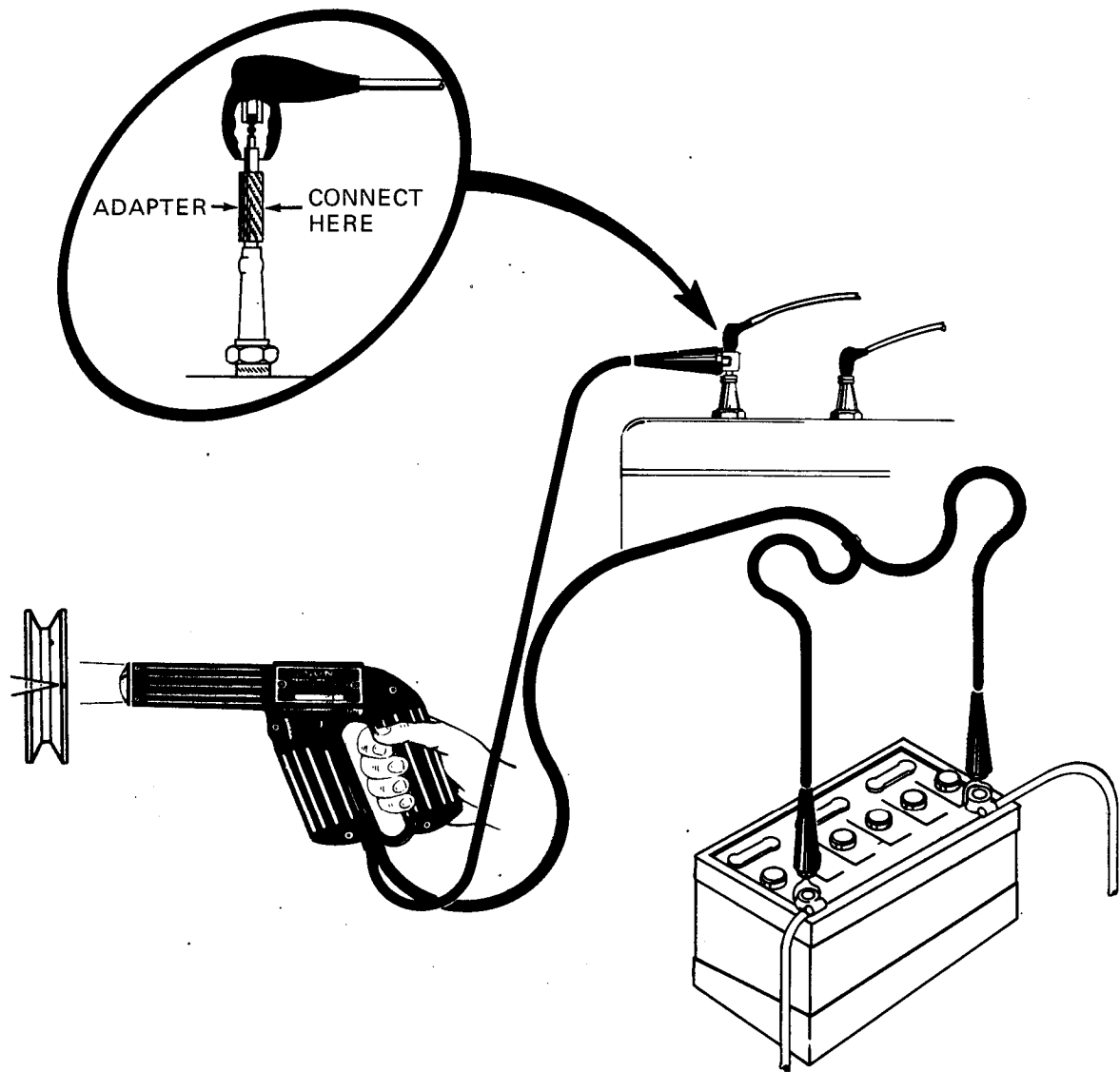

ME10-3930-626-12/4-4

Figure 4-4. Checking ignition timing.

#### 4-24. Manifold Vacuum Test

a. General. Performance of the manifold vacuum test will provide an indication of sticky valves, leaking head gasket, fouled spark plugs, carburetor adjustment, timing adjustment and mechanical drag.

b. Procedure.

(1) Remove PCV valve elbow from intake

manifold. Elbow is located directly above exhaust manifold heat control valve.

(2) Install vacuum gage hose adapter in hole, and connect vacuum gage hose to adapter (fig. 4-5).

(3) With engine warm and idling at 450 to 500 rpm, vacuum gage reading should be between 18 and 20 inches of mercury, and steady. Refer to figure 4-5 for normal and abnormal indications.

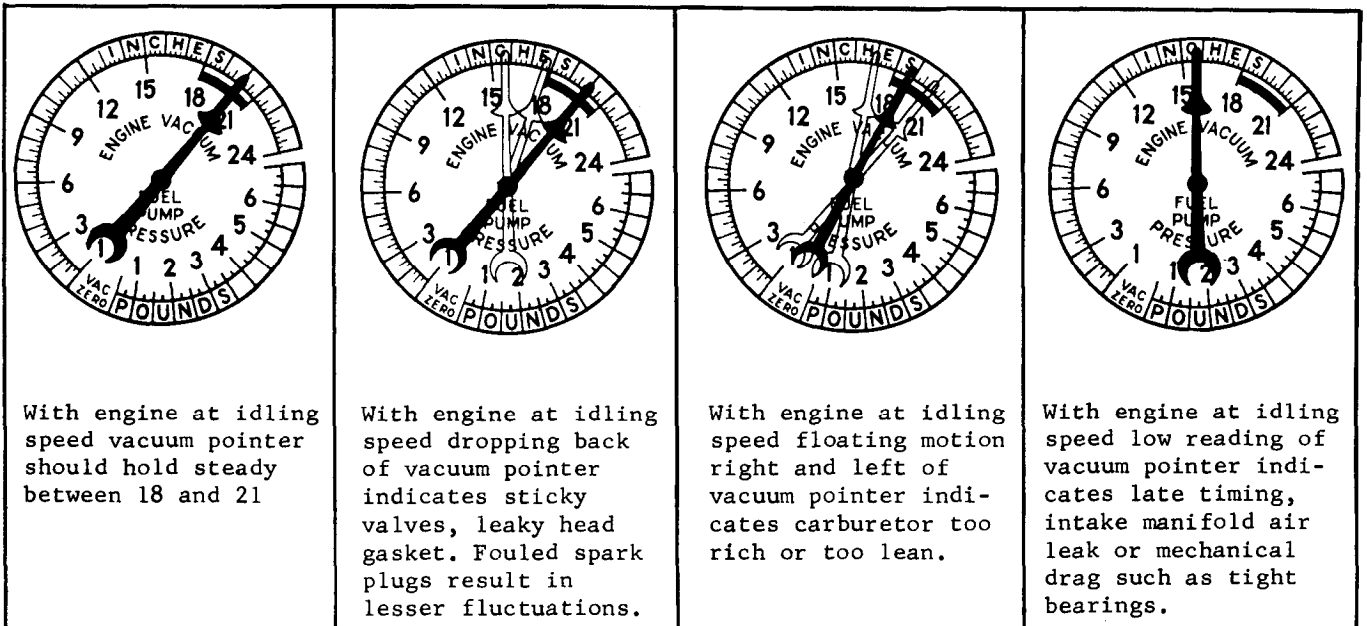
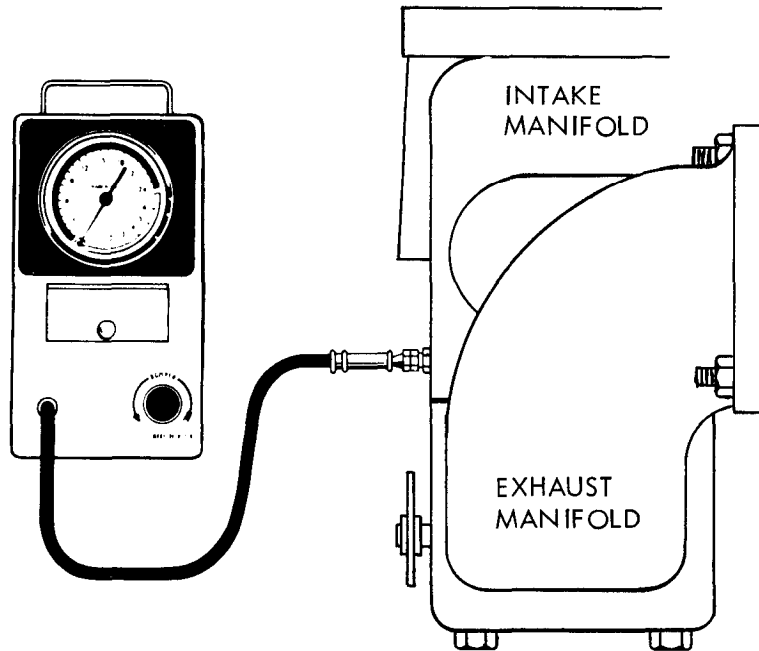

ME10-3930-626-12/4-5

Figure 4-5. Manifold vacuum test.

## 4-25. Cylinder Head and Head Gasket

### a. Removal (fig. 4-6).

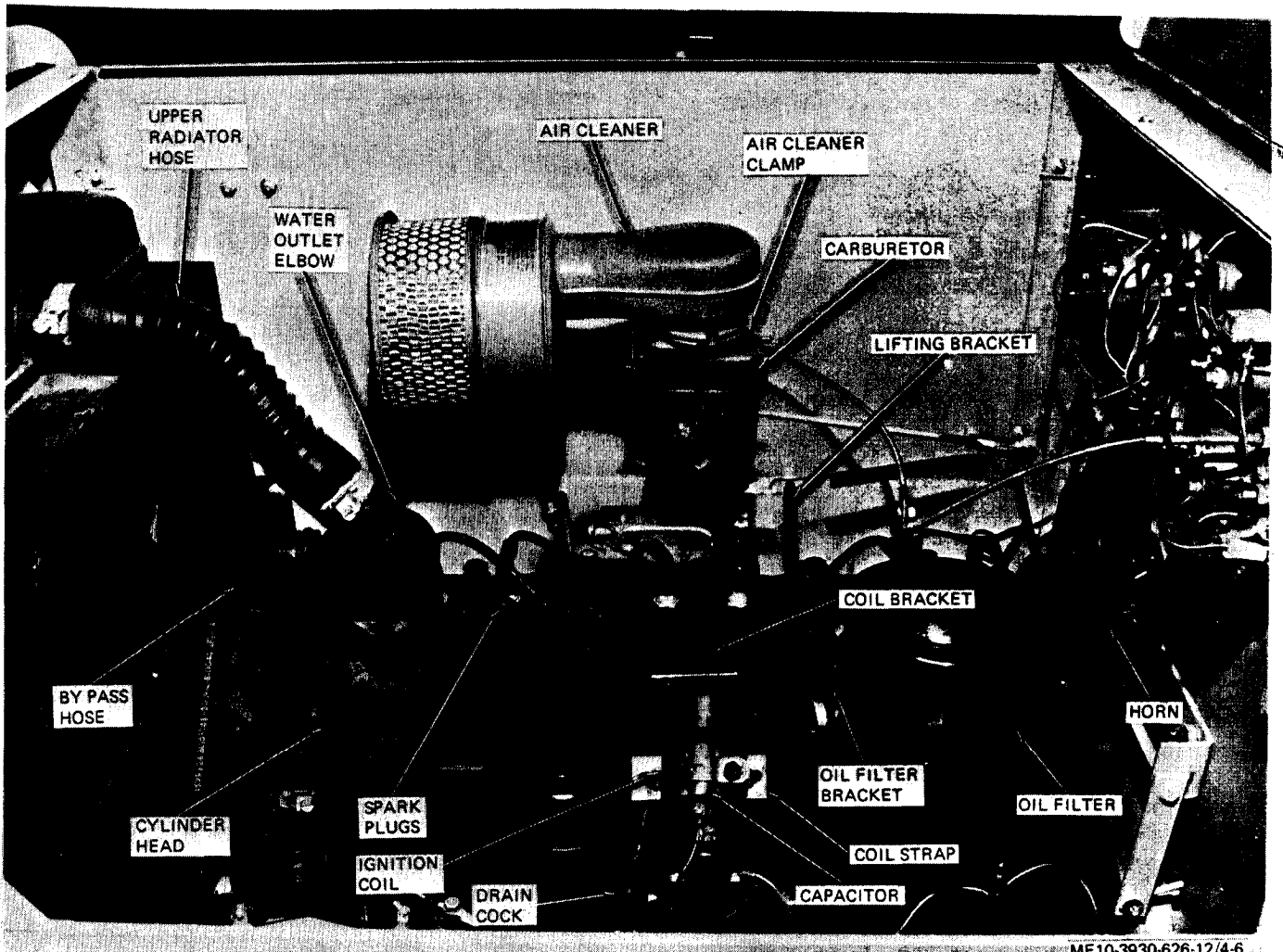

ME10-3930-626-12/4-6

Figure 4-6. Partial view of right side of engine.

(1) ~~Open drain cocks at bottom of radiator and on side of cylinder block and drain coolant. If coolant is clean, save it for reuse after assembly.~~

(2) Remove air cleaner (para 4-35).

(3) Remove spark plug wires from spark plugs. Remove spark plugs and spark plug gaskets.

(4) Disconnect and tag lead to horn and water temperature transmitter.

(5) Remove screw, lockwasher and flat washer securing horn and remove horn.

(6) Support oil filter and remove two screws and washers securing oil filter bracket to cylinder head.

(7) Remove screw and washer securing coil bracket to cylinder head and remove bracket with attached coil.

(8) Loosen hose clamps securing bypass hose to water outlet elbow and water pump and remove hose.

(9) ~~Remove two screws and lockwashers securing water outlet elbow and move elbow with attached upper radiator hose away from cylinder head. Remove water outlet elbow gasket, thermostat and thermostat gasket from cylinder head.~~

(10) Remove two nuts and flat washers securing lifting bracket to cylinder head and remove lifting bracket.

(11) Remove five head bolts from center of cylinder head.

(12) Remove fourteen tapped head bolts from rear, left and right sides of cylinder head. Lift off cylinder head. Remove and discard head gasket.

### b. Cleaning.

(1) Soak cylinder head in SD. Dry with compressed air and clean rags.

(2) Scrape carbon from inside of combustion chamber area with carbon scraper, or use a wire brush. Do not scratch surface when scraping.

(3) Scrape or brush surface to remove gasket paste residue.

*c. Inspection.* Inspect head for cracks and plugged water passages. Check for warpage with a good straight-edge and feeler gage in three positions lengthwise and five crosswise. The maximum permissible irregularity is 0.024 inch out lengthwise, or 0.006 inch crosswise.

*d. Installation.*

(1) Reverse procedures in *a* above, using new gaskets.

(2) Tighten each cylinder head bolt to 65 to 70 foot-pounds torque, following the tightening sequence in figure 4-7. Retorque head bolts after engine has been run and is still warm.

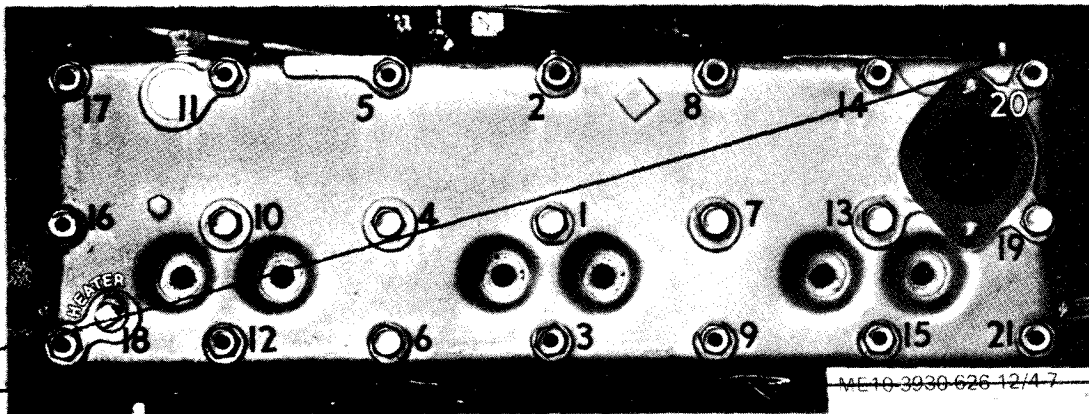

Figure 4-7. Cylinder head bolt tightening sequence.

#### 4-26. Valves

*a. Valve Cover Removal.*

- (1) Open hood and remove right side panel from engine compartment.
- (2) Remove air cleaner (para 4-35 *a*).
- (3) Remove carburetor and governor (para 4-36 and 4-39).
- (4) Remove manifolds (para 4-27).
- (5) Remove two bolts and gaskets securing each valve cover and remove valve covers. Remove and discard cover gaskets and cover bolt gaskets.

*b. Valve Adjustment.*

(1) Crank engine by hand until scribed mark on crankshaft pulley is aligned with pointer on gearcase cover. At this point both exhaust and intake valve will be open at number 1 cylinder (lifters cannot be turned or difficult to turn with fingers), and both exhaust and intake valves will be closed at number 6 cylinder or vice versa, depending on whether number 1 or number 6 is in firing position.

(2) If valves at number 1 cylinder are open, adjust valve clearance at cylinders number 2, 3 and 6. Then turn engine one full revolution and adjust valve clearance at cylinders number 1, 4 and 5. Valve clearance on intake valves is 0.010 inch cold. Valve clearance on exhaust valves is 0.016 inch cold.

(3) Insert feeler gage corresponding to appropriate valve given in (2) above between lifter adjusting screw and valve stem (fig. 4-8).

(4) Hold lifter with one wrench and turn lifter adjusting screw with a second wrench. A slight drag

should be felt with the feeler gage when the clearance is correct.

(5) To increase clearance, hold valve lifter stationary and turn adjusting screw clockwise.

(6) To decrease clearance, hold valve lifter stationary and turn adjusting screw counterclockwise.

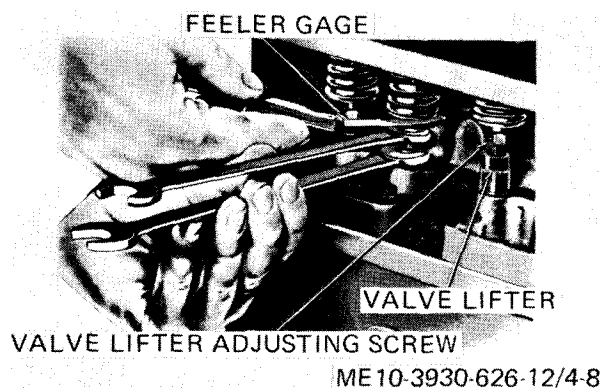

Figure 4-8. Valve adjustment.

*c. Valve Cover Installation.*

- (1) Clean valve covers in SD.
- (2) Reverse procedure in *a* above using new valve cover and valve cover bolt gaskets.

#### 4-27. Intake and Exhaust Manifolds

*a. Removal.*

- (1) Open hood and remove right panel from engine compartment.
- (2) Remove right side panel.

- (3) Remove air cleaner (para 4-35).
- (4) Remove carburetor (para 4-36 b).
- (5) Slide governor off carburetor mounting studs.
- (6) Disconnect exhaust pipe from exhaust manifold (para 4-44 b (2)).
- (7) Remove assembled intake and exhaust manifolds by removing attaching nuts and washers (fig. 4-9).

(8) Lift manifolds off studs. Remove and discard center and end gaskets.

(9) Remove screws attaching intake manifold to exhaust manifold. Discard gasket.

*Note.* Use care when removing intake to exhaust manifold screws. Constant heating and cooling may have frozen screws in place. Use a good grade penetrating oil and allow to stand several minutes before attempting removal.

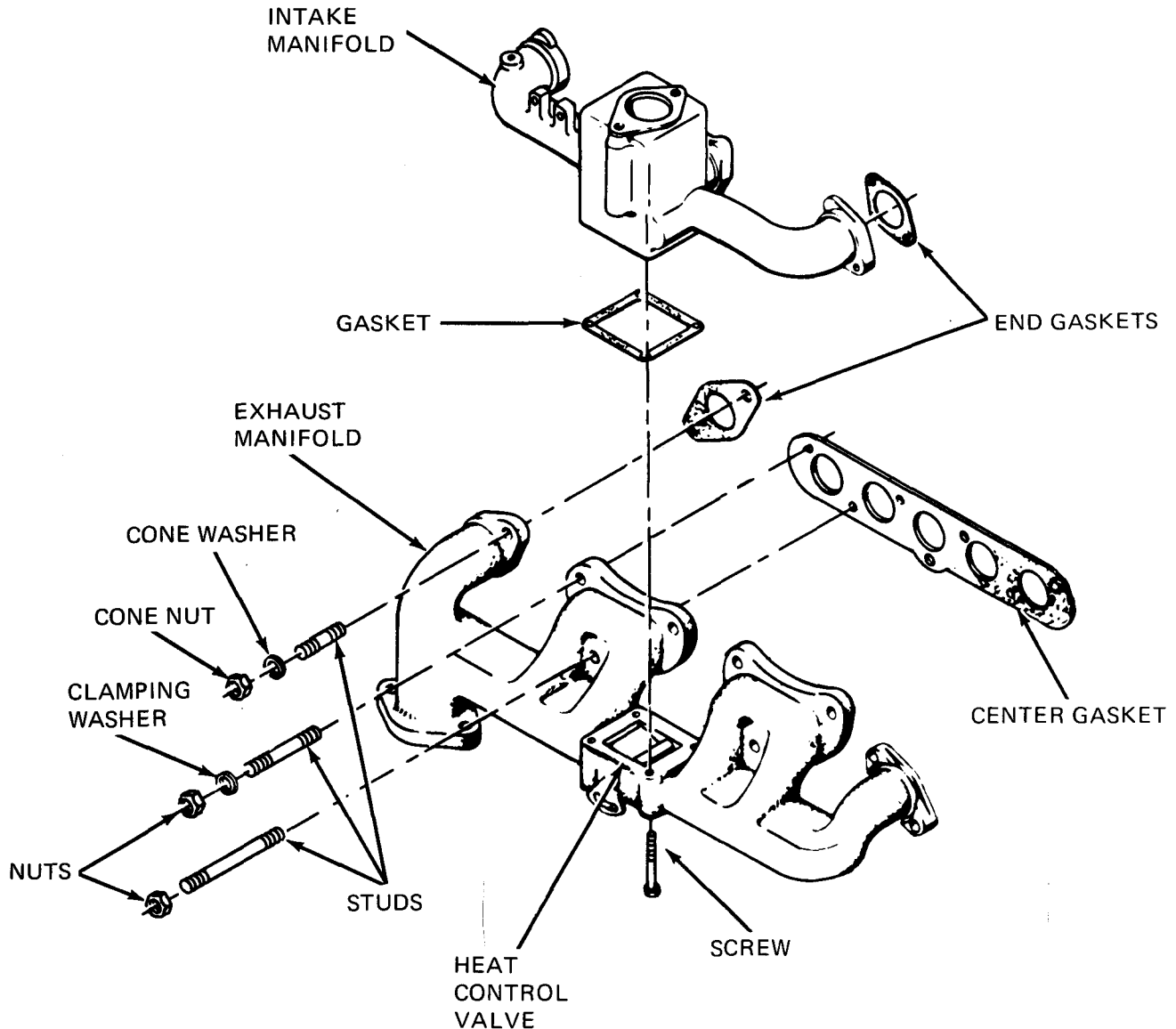

ME10-3930-626-12/4-9

Figure 4-9. Engine manifolds, exploded view.

*b. Cleaning.* Soak manifold in SD long enough to soften crusted deposits. Clean machined surface with flat bladed scraper. Clean bores of passages with scraper and wire brush. Dry with clean cloths.

*c. Inspection.* Inspect for warpage at machined surfaces with straight edge. The surfaces should be

flat within 0.0008 inch. Replace manifold if warpage is bad enough to be possible source of leaks. Check for cracks or distortion. Check heat control valve for free operation.

d. Installation.

(1) Using new gaskets, reverse procedure in a above.

(2) Do not fully tighten screws attaching intake manifold to exhaust manifold until after manifolds are completely installed and attaching hardware fully tightened.

(3) To avoid heat cracking of exhaust manifold, be certain to install four cone washers and cone nuts on extreme ends of exhaust manifold. Ensure that washer recess mates with nut cone face to allow movement of exhaust manifold without loosening due to expansion and contraction of manifold.

*rescribed see Cr 3*  
~~4-28. Water Pump, Fan, and Fan Belt~~

a. Removal.

(1) Open drain cocks in engine block and lower right corner of radiator and allow coolant to drain. If coolant is clean, allow it to drain into a clean container and save for reuse.

(2) Loosen screw securing adjusting arm to generator (fig. 4-10). Push generator toward engine block to slacken fan belt. Then remove fan belt from fan and water pump pulley.

(3) Remove four screws and lock washers which secure fan and pulley (fig. 4-11) to water pump. ~~Remove fan, fan spacer, and pulley.~~

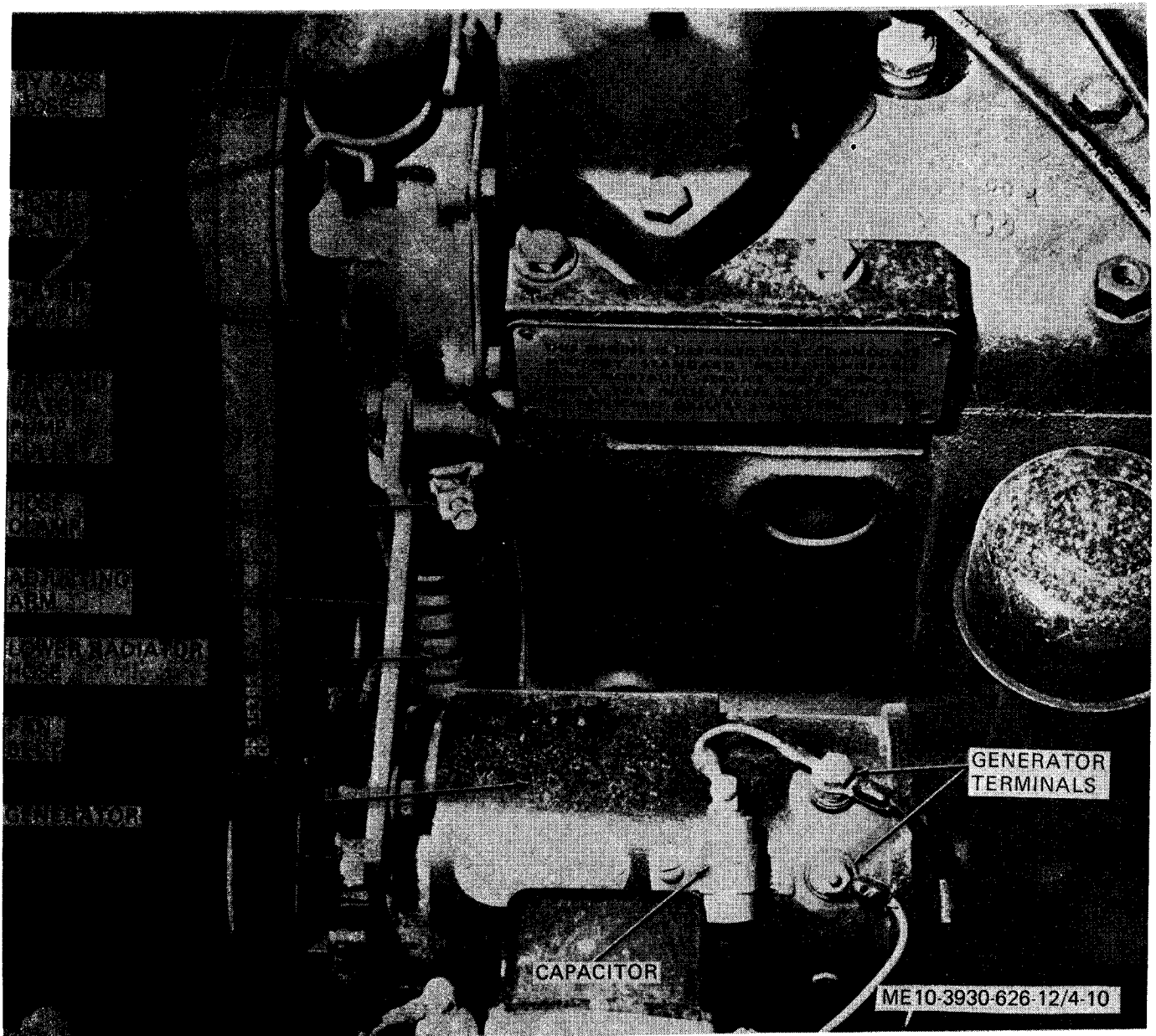
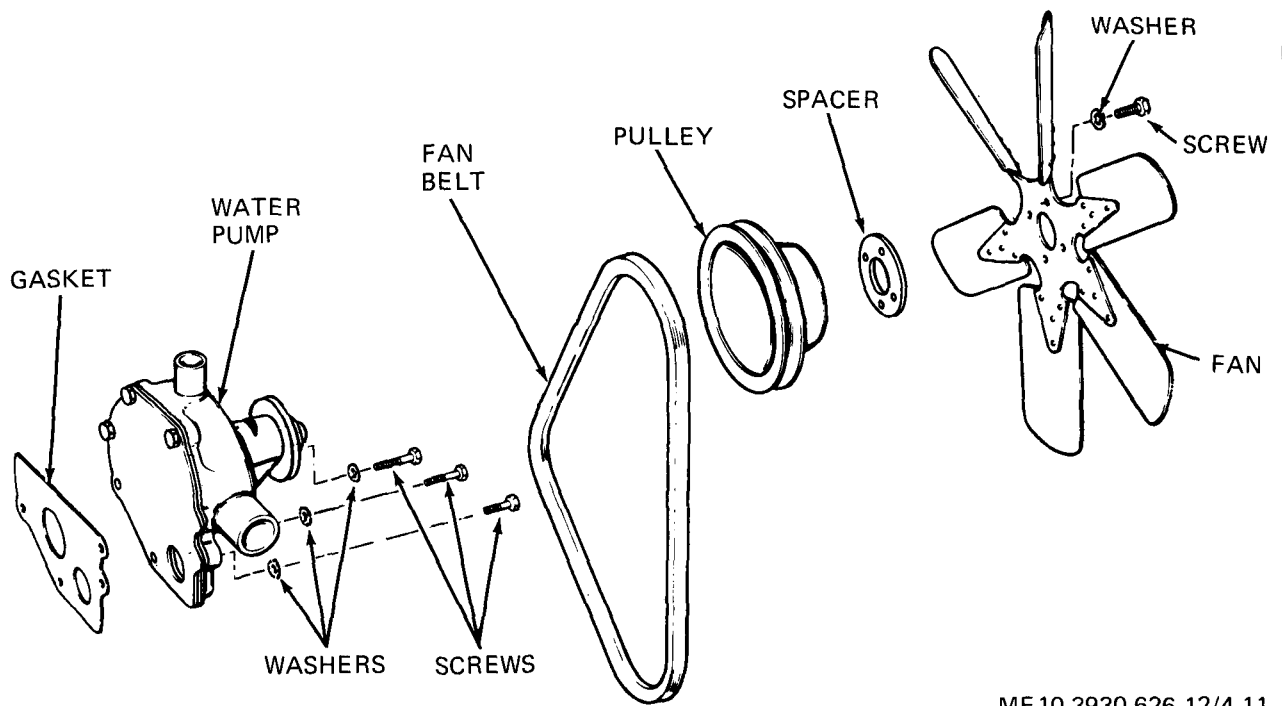

Figure 4-10. Fan belt and water pump installation.



ME 10-3930-626-12/4-11

Figure 4-11. Water pump, fan and fan belt.

See ch 3 rev

(4) Loosen hose clamps on bypass hose and remove hose from water pump.

(5) Loosen hose clamp on lower radiator hose and remove hose from water pump.

(6) Remove three screws and lock washers which secure water pump to engine block. Withdraw water pump and gasket (fig. 4-11). Discard gasket.

**b. Inspection.**

- (1) Inspect water pump for secure mounting.
- (2) Inspect water pump bearings for noise.
- (3) Inspect water pump for evidence of coolant leakage.

(4) Inspect fan for secure mounting, bent or cracked blades.

(5) Inspect fan belt for wear, frays, and proper adjustment of 1/2 in. finger pressure deflection at midpoint between generator pulley and fan pulley. Replace belt if frayed, cracked or deteriorated in any way.

**c. Installation.** Reverse procedure in *a* above using new water pump mounting gasket.

**d. Adjustment of Belt.**

(1) Loosen screw securing adjusting arm to generator (fig. 4-10) and loosen generator mounting screws.

(2) Pivot generator for desired belt tension (*b* above) and tighten adjusting arm screw and

**4-29. Spark Plugs.**

**a. Removal.** Remove spark plug cables from plugs, blow all loose dirt from spark plug area and unscrew spark plugs. Discard spark plug gaskets.

**b. Inspection.**

(1) Inspect shell for breaks and stripped threads.

(2) After removal (*a* above), check insulation for breaks, cracks, or chips.

(3) Check for carbon deposits, oil film, and burned electrodes.

**c. Cleaning and Test.**

(1) Clean spark plugs with an abrasive type spark plug sand blaster. After cleaning remove all traces of abrasive from inside spark plug.

(2) Test spark plugs with an approved spark plug tester.

**d. Adjustment.** File center electrode flat, and after cleaning, adjust gap to 0.035 inch by bending side electrode only.

**e. Replacement.** Replace plugs that are obviously damaged, that fail to pass test, or have severely burned electrodes.

**f. Installation.** Reverse *a* above, torquing plugs to 25 to 30 foot-pounds torque. Use new spark plug gaskets.



## Section IX. COOLING SYSTEM

### 4-30. General

The cooling system components covered in this section are located at the front of the engine compartment.

### 4-31. Radiator Hoses

*a. Inspection.* Inspect upper radiator hose (fig. 4-6) and lower radiator hose (fig. 4.10) for cracks, bulges, or deterioration. Also carefully inspect connections between hoses and engine and between hoses and radiator for evidence of coolant leakage. Tighten hose clamps if leakage is occurring.

*b. Removal (Either Radiator Hose).*

(1) Open drain cocks in radiator and engine block. Allow system to drain.

(2) Loosen hose clamps and slide toward center of hose.

(3) Grasp hose firmly and pull from engine and radiator connections.

*c. Installation.* To install radiator hose, reverse the above removal procedure. Be sure to check for coolant leakage after starting engine and full warm up.

### 4-32. Thermostat

*a. Removal.*

(1) Open drain cocks in radiator and engine block. Drain cooling system.

(2) Remove upper radiator hose (para 4-30 *b*).

(3) Release hose clamp on bypass hose (fig. 4-6), and work hose free from water outlet elbow.

(4) Remove cap screws securing water outlet elbow to cylinder head.

(5) Remove gasket (18, fig. 4-12). Discard gasket.

(6) Remove thermostat (19) and thermostat gasket (20). Discard gasket.

*b. Testing.*

(1) Suspend thermostat in a container of water so that it does not touch the bottom of the container.

(2) Heat water and check temperature with a thermometer. The thermostat valve should start to open at about 157° F., and should be fully open at 183° F.

(3) If the thermostat opens before the water temperature reaches 157° F., or does not open until after the water temperature reaches 183° F., it should be replaced.

*c. Installation.* Reverse procedure in *a* above using new gaskets (18 and 20).

4-30.1 (added)

Dec 26 3

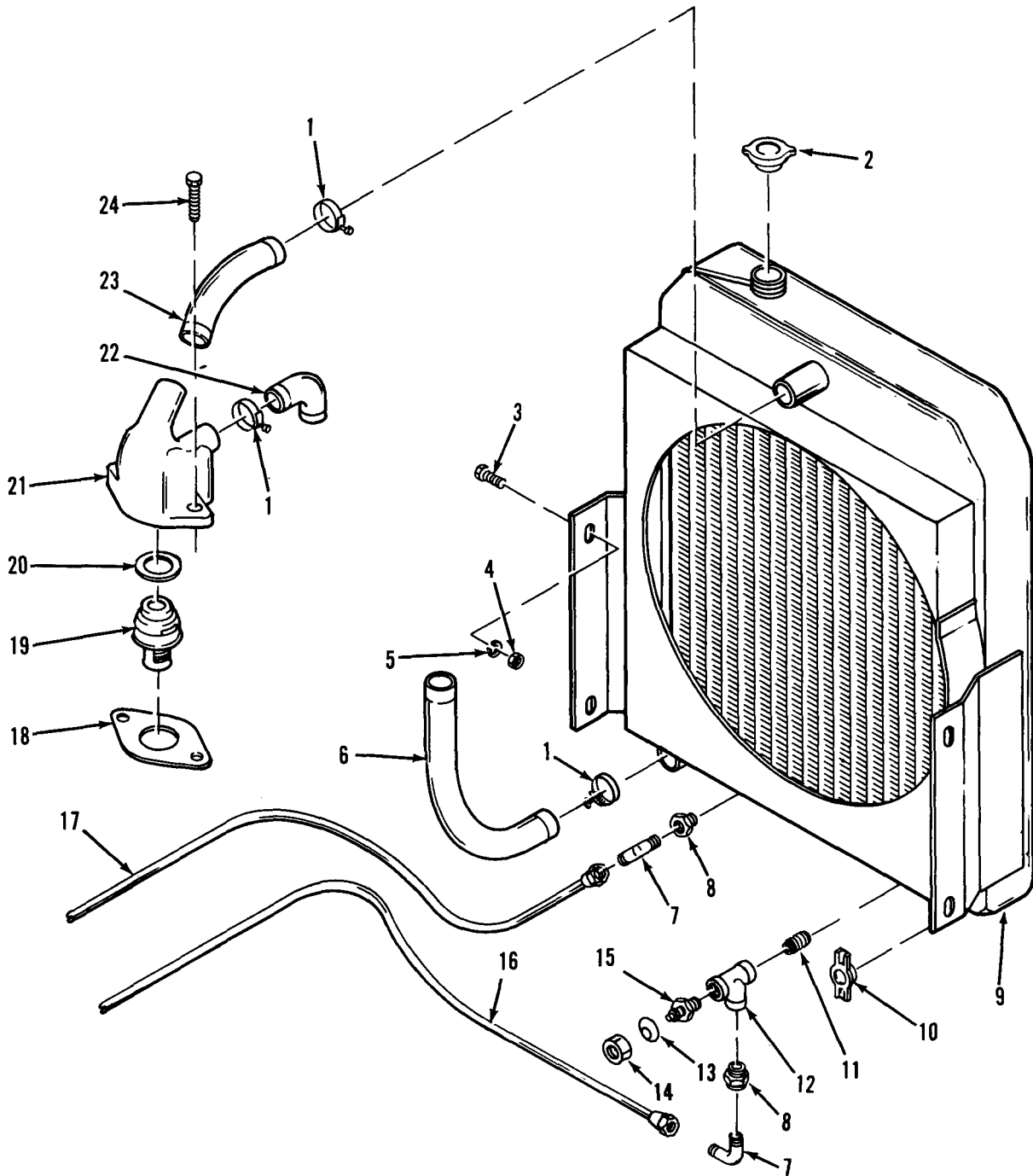

ME10-3930-626-12/4-12

- |                        |                                     |                                    |
|------------------------|-------------------------------------|------------------------------------|
| 1. Clamp               | 9. Radiator                         | 17. Transmission cooler inlet line |
| 2. Radiator cap        | 10. Drain cock                      | 18. Gasket                         |
| 3. Screw               | 11. Nipple                          | 19. Thermostat                     |
| 4. Nut                 | 12. Tee                             | 20. Thermostat gasket              |
| 5. Washer              | 13. Washer                          | 21. Water outlet elbow             |
| 6. Lower radiator hose | 14. Nut                             | 22. Bypass hose                    |
| 7. Elbow               | 15. Transmitter                     | 23. Upper radiator hose            |
| 8. Reducer             | 16. Transmission cooler outlet line | 24. Screw                          |

Figure 4-12. Cooling system, exploded view.

### 4-33. Radiator

*a. Inspection.* Inspect radiator for damage to fins and coolant tubes. Also inspect for leakage at transmission tubes and at radiator hoses.

*b. Removal.*

(1) Raise hood and remove side panels from engine compartment.

(2) Remove radiator cap (2, fig. 4-12), open drain cock (10) at bottom of radiator and open drain cock on engine block to drain cooling system.

(3) Loosen nut (14) and washer (13) and disconnect lead from transmitter (15).

(4) Loosen clamps (1) from upper hose (23) and lower hose (6) and disconnect from radiator (9).

(5) Disconnect transmission cooling lines (16 and 17) at radiator and cap lines.

(6) Loosen fan belt (para 4-28 *a* (2)). Remove fan, spacer and pulley (para 4-28a (3)).

(7) Remove four screws (3, fig. 4-12), nuts (4) and lock washers (5) securing radiator. Lift radiator from tractor.

*c. Installation.* Reverse procedure in *b* above. Adjust fan belt (para 4-28 *d*).

## Section X. AIR INTAKE AND FUEL SYSTEM

### 4-34. General

This section covers components related to fuel and air supply and control. These components include the air cleaner, carburetor, fuel pump, governor and fuel tank.

### 4-35. Air Cleaners

*a. Removal.*

(1) Loosen screw in air cleaner clamp (fig. 4-6).

(2) Lift air cleaner and clamp off carburetor.

(3) Remove gasket from carburetor intake.

**Caution: Use care to prevent foreign matter from entering carburetor inlet while air cleaner is removed.**

*b. Installation.* Install air cleaner by reversing removal procedure in *a* above. Tighten screw in air cleaner clamp securely.

### 4-36. Carburetor

*a. Adjustment.*

(1) Connect vacuum gage to intake manifold (para 4-24 *b* (2)), and tachometer to engine. Start and warm up engine.

(2) With throttle screw (fig. 4-13), adjust engine idle to 450 to 500 rpm.

(3) Adjust idle mixture screw to setting giving the highest possible vacuum reading.

Note. While making idle mixture adjustment, maintain given idle speed with throttle screw.

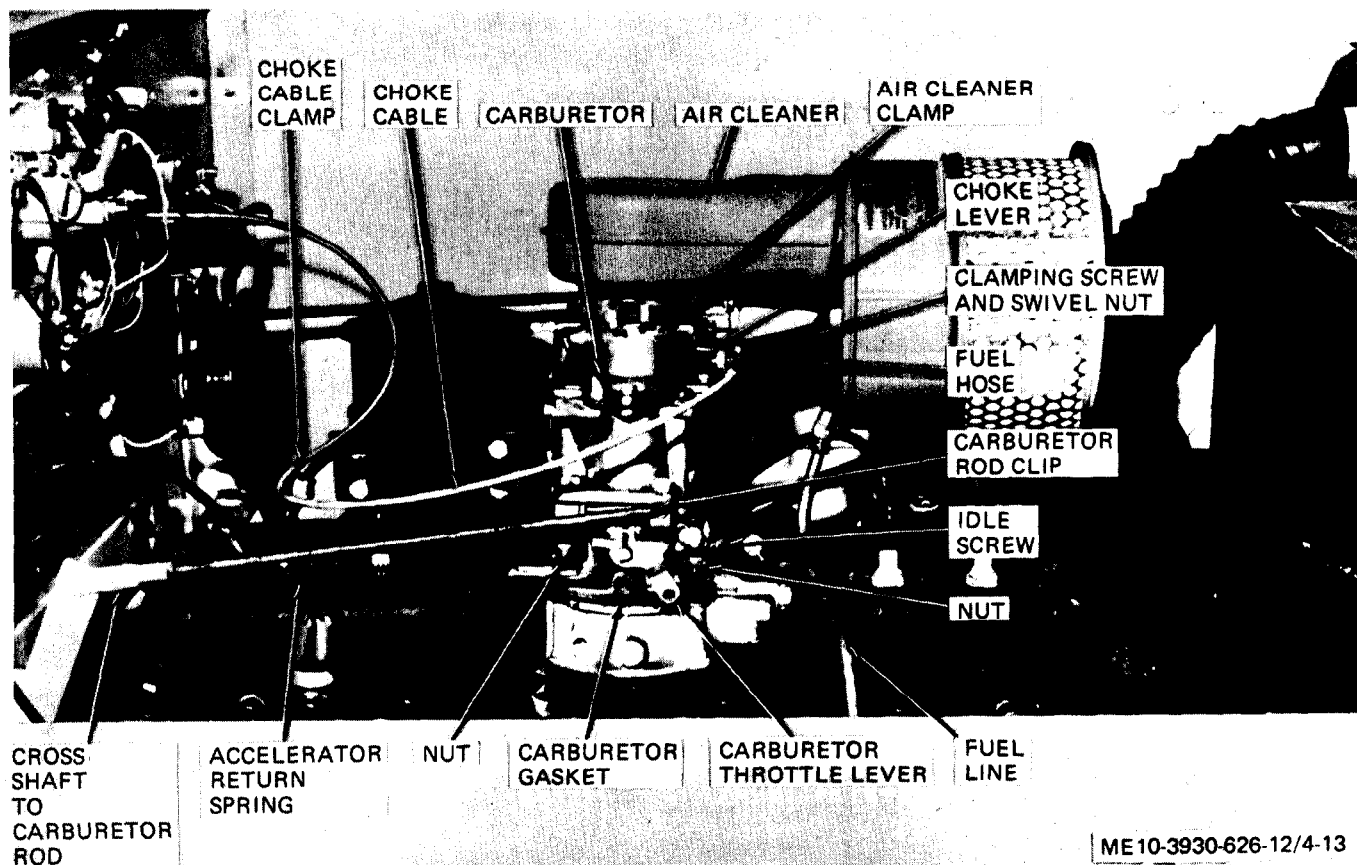

Figure 4-13. Carburetor and linkage.

*b. Removal.*

- (1) Open hood and remove panel from right side of engine compartment.
- (2) Remove air cleaner (para 4-35 a).
- (3) Disconnect accelerator return spring from carburetor clip (fig. 4-13).
- (4) Remove carburetor rod clip and disconnect cross shaft to carburetor rod at carburetor throttle lever.
- (5) Loosen screw and swivel nut on choke lever and disconnect choke cable.
- (6) Disconnect fuel hose at carburetor elbow.
- (7) Remove stud nuts attaching carburetor to governor and remove carburetor and mounting gasket. Discard gasket.

*c. Installation.* Reverse procedure in *b* above using a new mounting gasket. With choke button depressed, fully open choke plate and connect choke cable to choke lever.

**4-37. Fuel Pump**

*a. Cleaning.*

- (1) Lift and block front end of tractor to a suitable working height.
  - (2) Close fuel shut-off valve at bottom of fuel tank.
  - (3) Loosen nut (fig. 4-14) at bottom of bail and remove bail, bowl, spring, filter element and bowl gasket from pump. Discard gasket.
- Caution: Some gasoline will probably be spilled at this time from the bowl. Take precautions against fire.**
- (4) Rinse bowl and filter element in SD, and reassemble, using a new gasket between bowl and pump.
  - (5) Open fuel tank shut-off valve.

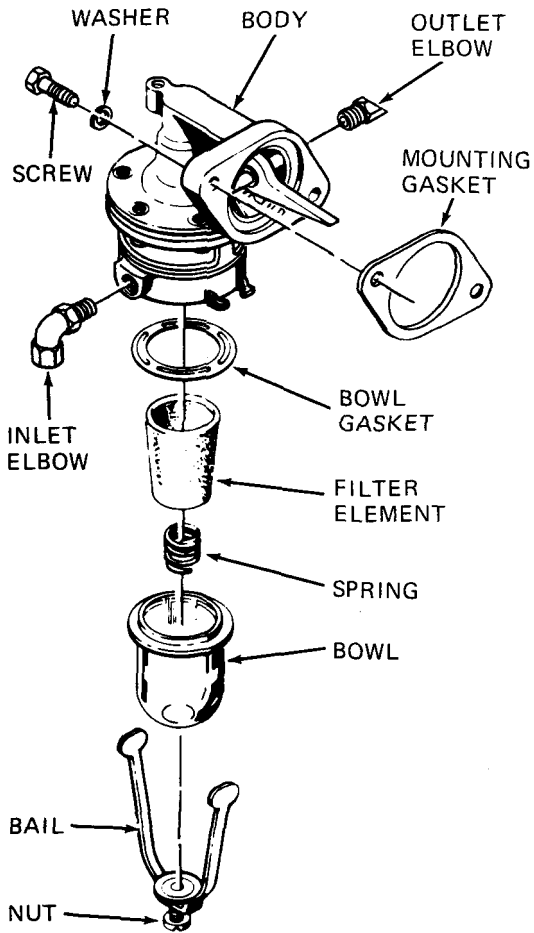

ME10-3930-626-12/4-14

Figure 4-14. Fuel pump.

*b. Tests.* In order to assure an adequate quantity of fuel and a constant fuel level at all driving conditions, it is necessary that both fuel pump pressure and volume be within specifications. The only reliable pressure test is one made under actual operating conditions (i.e., with fuel pump supplying fuel to carburetor and with a pressure gage located within six inches and connected to the fuel line).

(1) *Connections.*

(a) Remove air cleaner and disconnect fuel line at carburetor.

(b) Mount tester to carburetor inlet with gage in vertical position (fig. 4-15). Use adapters if necessary. Fittings need only to be "finger tight".

(c) Connect fuel line to fitting on fuel pump tester hose. Use adapter if necessary.

(d) Clamp fuel discharge hose on tester.

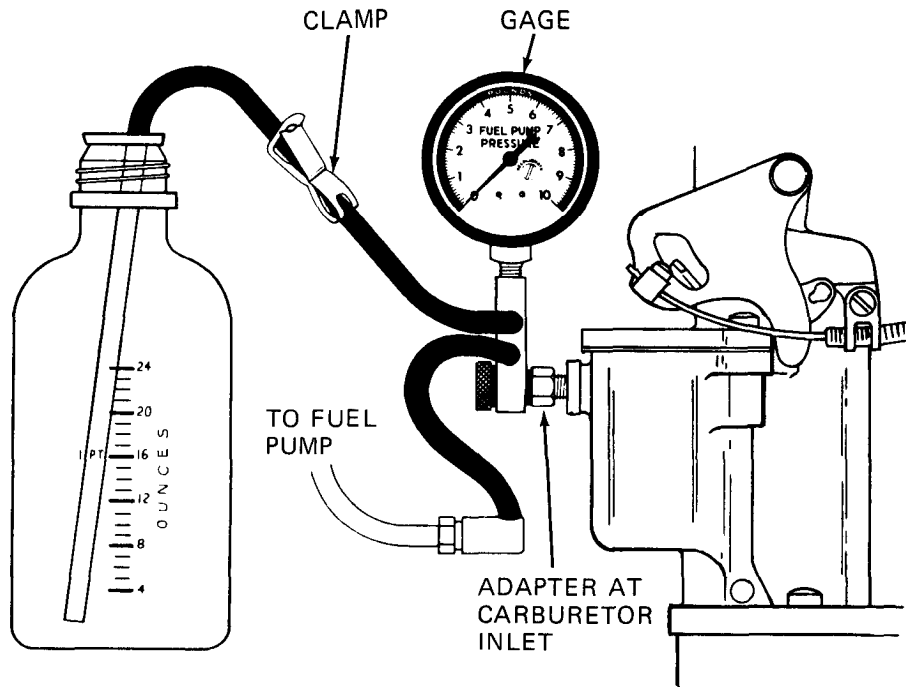

ME10-3930-626-12/4-15

Figure 4-15. Fuel pump test setup.

(2) Pump pressure and volume test.

(a) Start engine and run at 500 rpm.

(b) Insert volume test hose into graduated container and open fuel discharge hose clamp. When fuel reaches 4 ounce level, submerge end of hose in fuel and observe for bubbles.

(c) Note time required to pump one pint of fuel, then clamp fuel discharge hose.

**Caution: Dispose of fuel in graduated container to avoid a fire hazard. Adequate fuel delivery is available when a full pint flows in 30 seconds or less at 500 rpm.**

(d) With engine still running at 500 rpm, note gage reading on fuel pump tester. The gage reading is static pressure of fuel pump and reading should be 3½ pounds per square inch (rein) to 5 pounds per square inch (max).

(3) Results and indications.

(a) Pressure and volume within specifications indicate fuel pump and lines are in satisfactory condition.

(b) Pressure and volume ~~low~~ indicates a defective fuel pump, restricted or leaky fuel line.

(c) Pressure low with correct volume indicated defective fuel pump.

(d) Pressure normal with insufficient volume indicates restricted or leaky fuel line, or defective fuel pump.

(e) Air bubbles on volume test indicates leaky fuel line or fuel pump.

(4) Vacuum test. The fuel pump vacuum test is an auxiliary test that is necessary only when pump output does not meet pressure or volume specifications. The fuel pump vacuum test is made to determine whether the defect is in the pump or in the fuel line.

(a) Close fuel tank shut-off valve.

(b) Disconnect tank fuel delivery line at fuel pump.

(c) Install proper adapter fitting at fuel pump inlet and attach vacuum gage hose.

(d) Start engine and run at idle speed sufficient to permit vacuum gage to reach its maximum reading.

(e) Stop engine and observe vacuum gage for 10 or 15 seconds.

(5) Results and indications.

(a) If maximum vacuum is 8 inches or more, and does not fall off when engine is stopped, pump valves and filter bowl gaskets do not leak.

(b) If maximum reading is less than 8 inches or vacuum falls off rapidly, replace fuel pump.

*Note.* Line from fuel tank can be tested for air leaks in a similar manner by connecting vacuum gage hose to fuel line at tank end of line, and repeating test. A rapid fall-off of

See Ch 3

vacuum after engine is stopped would indicate air leaks into line somewhere between tank and fuel pump.

*c. Removal.*

(1) Close fuel tank shut-off valve and disconnect both fuel lines at fuel inlet and outlet elbows (fig. 4-14).

(2) Remove both screws and washers and remove pump. Remove and discard mounting gasket.

*d. Installation.* Reverse procedure in *c* above. Use new mounting gasket.

**4-38. Fuel Tank**

*a. Removal.*

(1) ~~Hoist tractor to obtain access to fuel tank.~~ *chg. to note: Lock 3*

(2) Remove drain plug (19, fig. 4-16), and drain all fuel into a container. Observe safety precautions for handling gasoline.

(3) Unscrew filler (7) with assembled strainer (6) complete from tank fill neck.

(4) Disconnect fuel tank tube (17) from shut-off valve (16) and remove shut-off valve.

(5) Remove nut (2) and washer (3) and disconnect lead to fuel sender (4).

(6) Remove screws (1) and washers (21) and remove fuel sender (4) and gasket (5).

(7) Remove screws (14) and nuts (15), then withdraw bracket tank support (13) and pad (12) from underneath fuel tank (9).

(8) Remove four screws (20) and remove fuel tank (9) from below.

Note. Fuel tank line (17) may interfere with tank removal. Disconnect at fuel pump and pull through grommet (18).

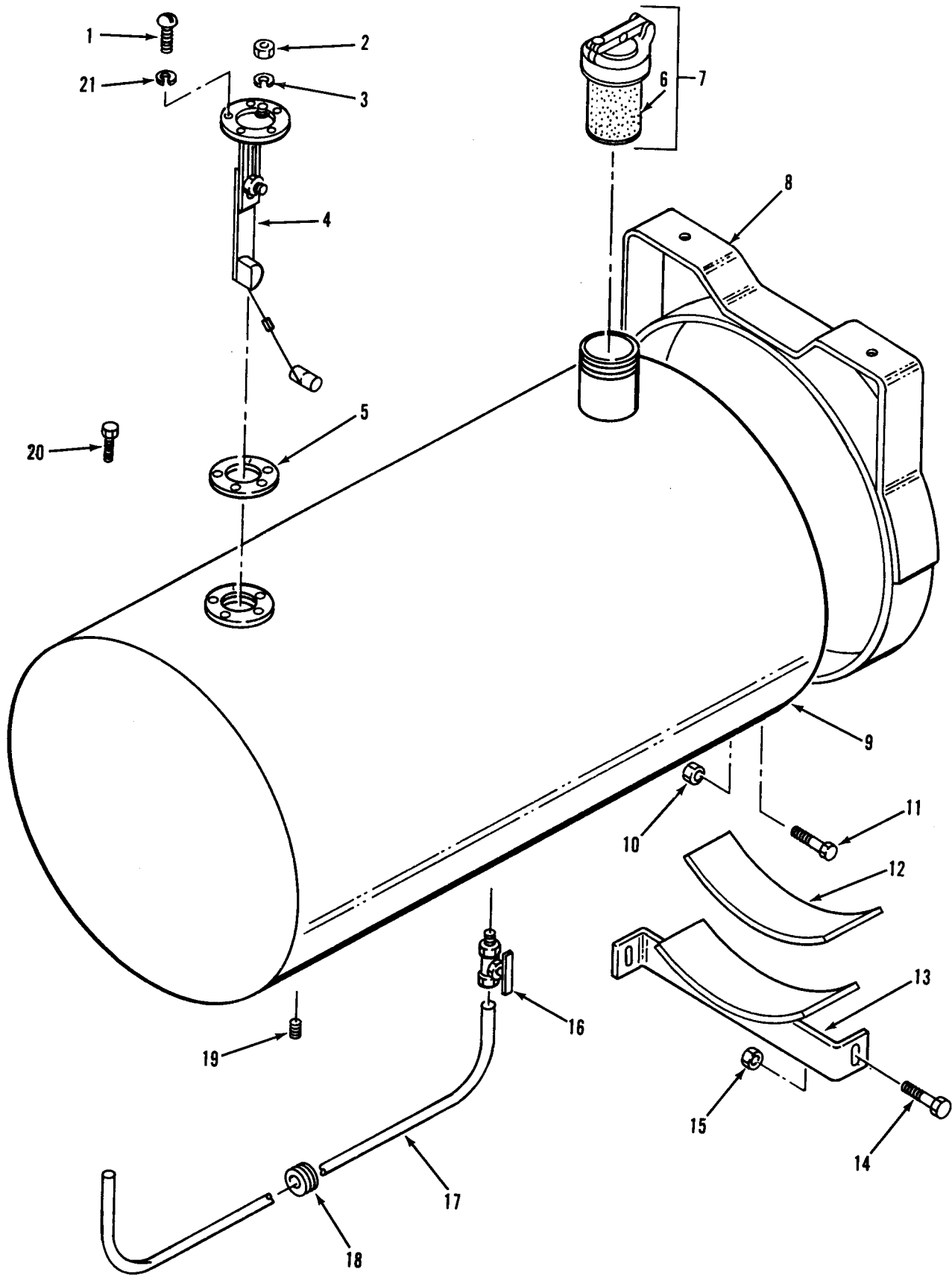

ME 10-3930-626-12/4-16

Figure 4-16. Fuel tank installation.



KEY to figure 4-16:

1. Screw
2. Nut
3. Lock washer
4. Fuel sender
5. Gasket
6. Strainer
7. Filler
8. Mounting clamp
9. Fuel tank
10. Nut
11. Screw
12. Pad
13. Tank support
14. Screw
15. Nut
16. Shutoff valve
17. Fuel tank tube
18. Grommet
19. Drain plug
20. Screw
21. Lock washer

*b. Cleaning.*

(1) Install drain plug (19) and shut-off valve (16). Close shut-off valve and put one gallon SD in tank and slosh it around. Pour out SD quickly through fill pipe, to carry out sediment.

(2) Air dry tank interior,

*c. Installation.* Reverse procedure in *a* above.

When installing support (13) and pad (12), force support upward so that pad is snug against tank; then, tighten nuts (15).

4-39. Governor

*a. General.*

(1) Leakage at manifold, carburetor or interconnecting gaskets must be corrected before governor can be properly adjusted,

(2) Thoroughly clean governor prior to making any adjustments. In many cases, satisfactory operation can be restored by cleaning carbon and gum deposits from governor.

(3) Start and run engine until normal operating temperature is reached before making adjustments.

*b. Speed Adjustment.*

(1) Attach tachometer to engine.

(2) Start and run engine at full throttle. Tachometer should indicate 2450 rpm.

(3) To adjust for higher speed, turn adjusting screw cap (fig. 4-17) counterclockwise, To adjust for lower speed, turn adjusting screw cap clockwise. One complete turn of adjusting screw cap will change engine speed approximately 300 rpm.

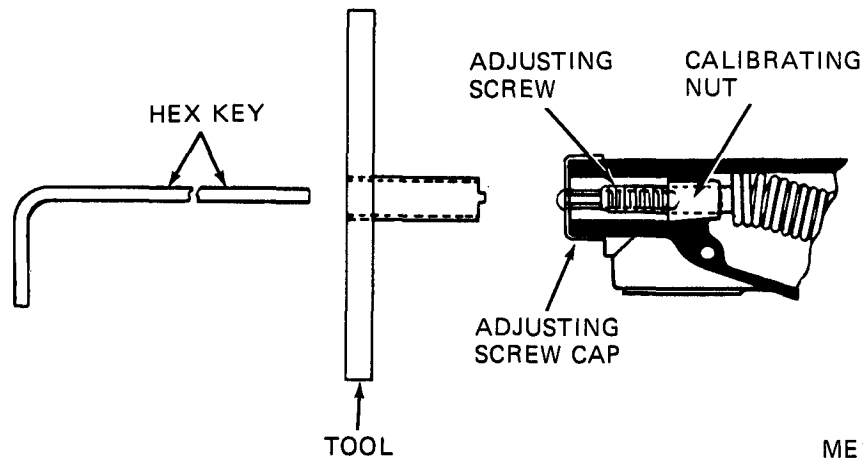

ME10-3930-626-12/4-17

Figure 4-17. Governor adjustment.

*c. Surge Adjustment.*

(1) Attach tachometer to engine.

(2) Start and run engine at full throttle.

(3) Remove adjusting screw cap (fig. 4-17).

(4) Fabricate tool from a short piece of metal tubing. Tubing inside diameter must exceed adjusting screw outside diameter and end must be cut with two tangs to engage slots in calibration nut. Handle may be added as shown in figure 4-17 if desired.

(5) Engage slot in calibration nut with tool.

(6) Engage adjustment screw with an appropriate hex key,

(7) Hold adjustment screw stationary with hex key and turn calibration nut clockwise  $\frac{1}{4}$  turn at a time until surge is minimized or eliminated.

(8) Readjust speed if necessary.

*d. Slow action adjustment.* If governor does not cut in promptly at maximum speed or does not cut out promptly at governed speed when load is applied, adjust for surge (subpara. *c* above) except turn calibration nut counterclockwise.

#### 4-40. Accelerator and Choke Linkages

##### a. Throttle Linkage Removal.

(1) Open left and right sides of hood.

(2) Remove two cotter pins (10, fig. 4-18) and flat washers (14) and remove pedal to cross shaft rod (11).

(3) Remove screws (15) and nuts (12), and remove pedal (13).

(4) Unhook spring (2) from clip at carburetor mounting stud and pin (6).

(5) Remove clip (3) and pin (6) and remove cross shaft to carburetor rod (4) with assembled clevis (7), Loosen nut (5), and remove clevis (7) and nut (5) from rod.

(6) Remove two screws (9) and nuts (8), and remove cross shaft (1) from engine compartment.

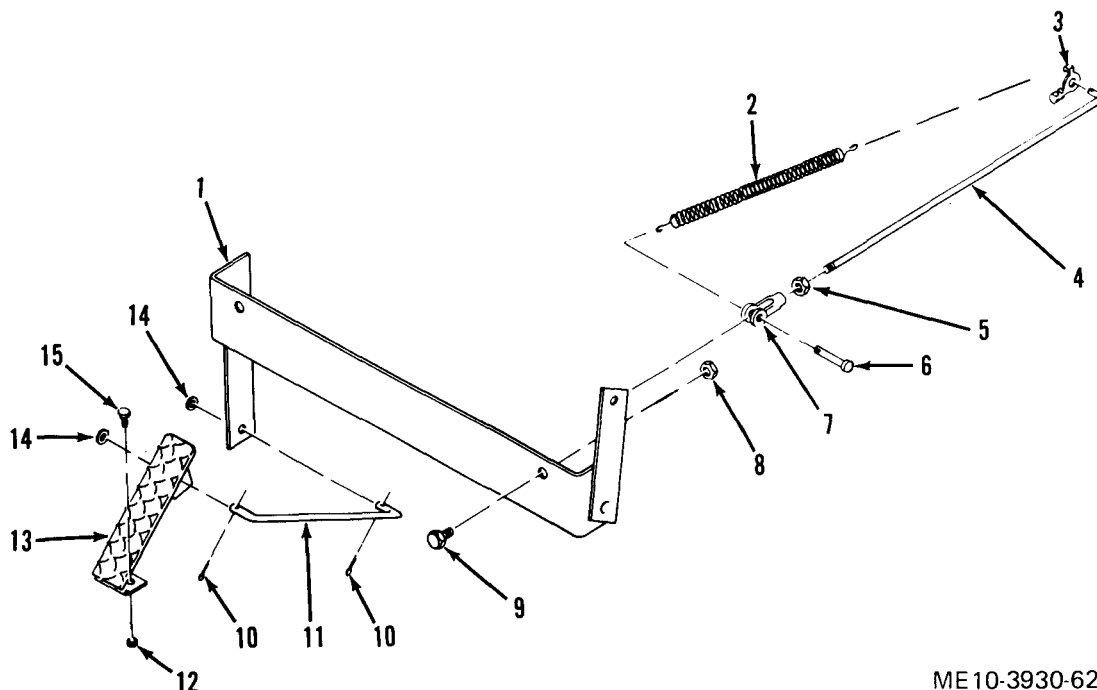

ME10-3930-626-12/4-18

- |                                  |                     |
|----------------------------------|---------------------|
| 1. Cross shaft                   | 9. Screw            |
| 2. Spring                        | 10. Cotter pin      |
| 3. Clip                          | 11. Cross shaft rod |
| 4. Carburetor to cross shaft rod | 12. Nut             |
| 5. Nut                           | 13. Pedal           |
| 6. Pin                           | 14. Flat washer     |
| 7. Clevis                        | 15. Screw           |
| 8. Nut                           |                     |

Figure 4-18. Carburetor linkage, exploded view.

b. Installation. Reverse procedure in a above.

##### c. Adjustment.

(1) With linkage installed, unsnap clip (3) and remove rod (4) from carburetor throttle lever.

(2) Fully depress pedal (13) and move carburetor throttle lever by hand to full throttle.

(3) Loosen nut (5) and turn rod (4) in or out of clevis (7) until rod end can be inserted through carburetor throttle lever. Secure with clip (3).

(4) Release pedal (13) and adjust carburetor if necessary for proper idle speed (para 4-36 a (2)).

##### d. Choke Cable Removal.

(1) Loosen clamping screw and swivel nut at

carburetor choke lever to release choke cable (fig. 4-13).

(2) Loosen screw in choke cable clamp.

(3) Remove nut and washer securing choke cable from engine compartment side of fire wall and pull out choke cable.

e. Installation. Reverse procedure in d above.

f. Adjustment. With choke cable installed, depress knob, fully open choke valve on carburetor by hand and secure cable to choke lever with locking screw swivel nut.

## Section XI. OIL FILTER SYSTEM

### 4-41. General

The oil filter system consists of the oil filter mounted on the left side of the engine (fig. 4-6) and the connecting lines.

### 4-42. Removal, Cleaning, and Installation

#### a. Filter and Lines Removal.

(1) Remove drain plug and drain oil from filter body (fig. 4-19).

(2) Remove pressure tube from elbow at side of filter body and remove return tube from elbow at bottom of filter body. Remove tubes from elbows on engine block.

(3) Remove four nuts, lock washers, screws and flat washers securing body to mounting bracket and remove body with attached mounting strap.

#### b. Cleaning and Inspection.

(1) Clean all parts in SD.

(2) Inspect body for cracks; kinked or pinched tubes; and stripped threads on hardware or tube fittings. *B) added see ch 3*

c. Installation. Reverse removal procedure in a above.

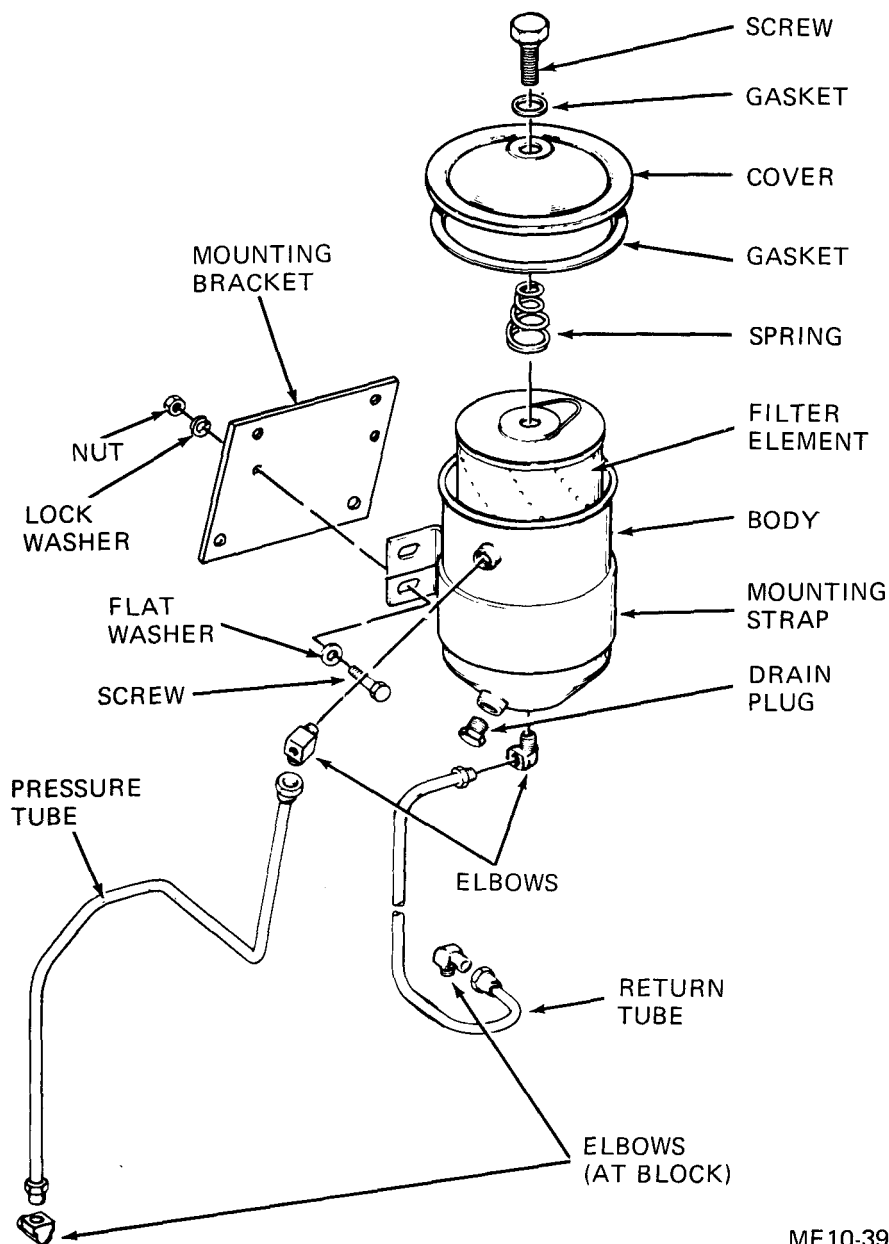

ME 10-3930-626-12/4-19

Figure 4-19. Oil filter and lines, exploded view.

## Section XII. EXHAUST SYSTEM

### 4-43. General

The exhaust system consists of an exhaust pipe and a muffler. The muffler incorporates a short integral tail pipe.

### 4-44. Inspection, Removal, and Replacement

*a. Inspection.* Inspect complete exhaust system for leaks, corrosion and security of attachment.

*b. Removal.*

(1) Open hood and remove panel from right side of engine compartment.

(2) Remove nuts (1, fig. 4-20) and screws (7) securing exhaust pipe (3) to exhaust manifold flange. Remove and discard gasket (2).

(3) ~~Raise rear of tractor to a suitable working height~~ and remove nut, lock washer and screw securing hanger (5) to tractor chassis.

(4) Remove nuts from U-bolt and clamp (4). Remove hanger (5) from muffler.

(5) Pull muffler (6) with attached exhaust pipe (3) from tractor.

(6) To remove muffler from exhaust pipe, remove U-bolt and clamp (4) and if necessary, heat joint with a oxyacetylene torch and pull exhaust pipe out of muffler.

*c. Installation.* Reverse procedure in *b* above. If muffler (6) or exhaust pipe (3) was replaced, be certain to clean end of mating part of all carbon and rust. Use new gasket (2). Be sure small drain hole in muffler is facing downward to allow condensation to escape from muffler.

chg 15+  
line  
sec ch 3

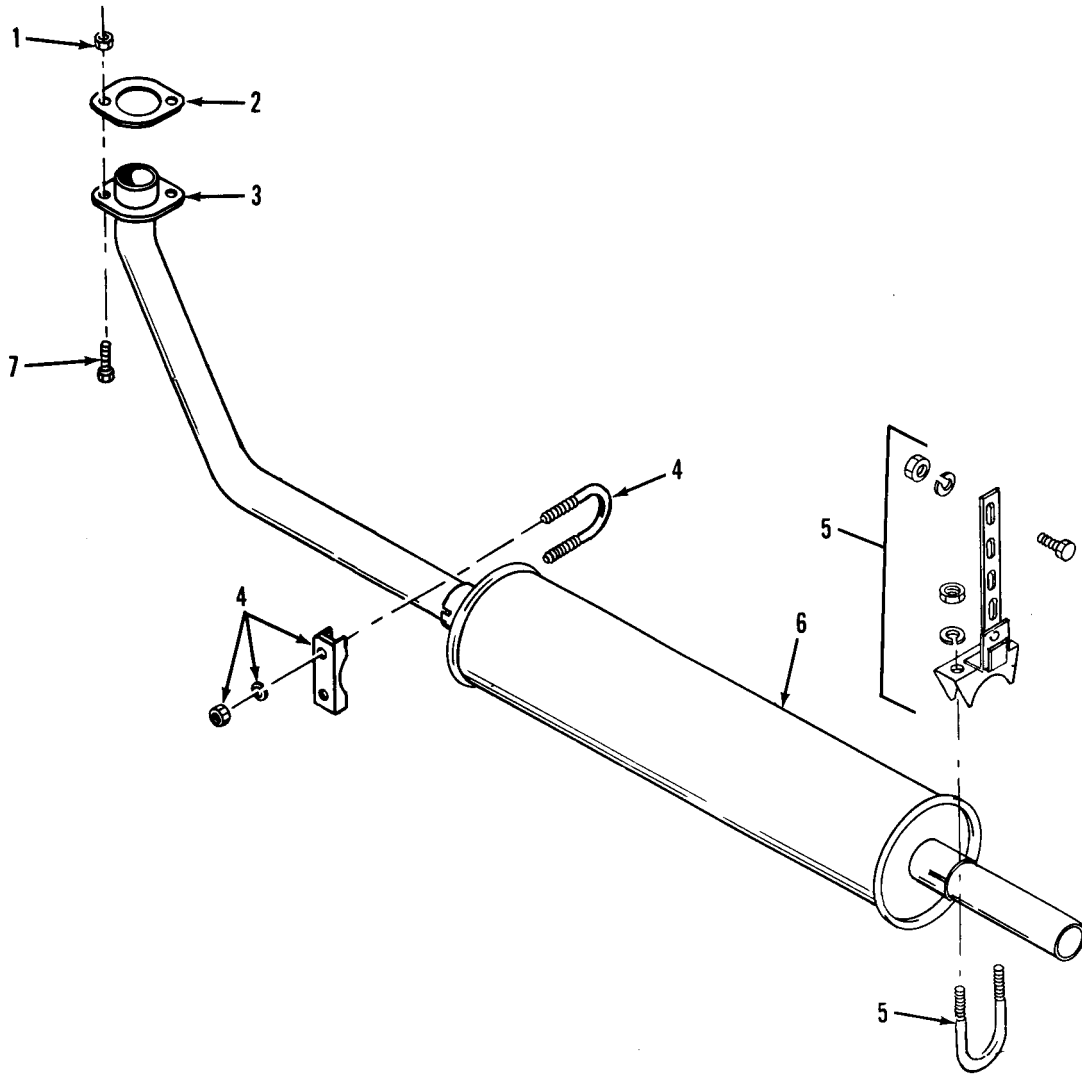

ME 10-3930-626-12/4-20

1. Nut
2. Gasket
3. Exhaust pipe
4. U-bolt and clamp
5. Hanger
6. Muffler
7. Screw

Figure 4-20. Exhaust system.

## Section XIII. ELECTRICAL SYSTEM

### 4-45. General

The electrical system consists of six basic circuits; starting, charging, ignition, horn, instrument, and lighting. The units of the various circuits are connected in a 12-volt, negative ground, single wire

system. When repairing or replacing wiring, refer to wiring diagram (fig. 4-21). This section covers organizational maintenance and repair of various components of the electrical system.

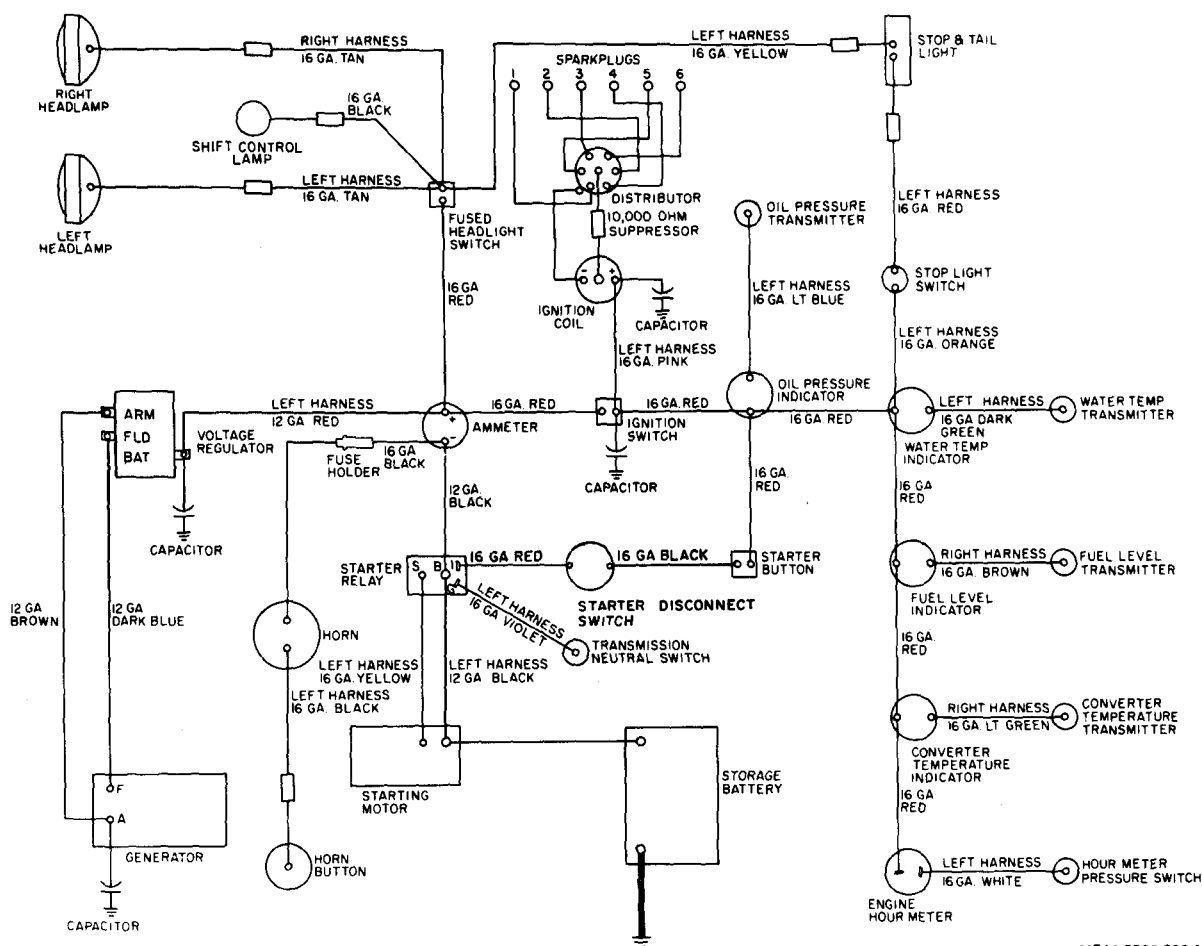

ME10-3930-626-12/4-21

Figure 4-21. Wiring diagram.

#### 4-46. Generator

##### a. Output Test.

(1) Disconnect lead from BAT terminal of regulator, and connect ammeter in circuit as shown in figure 4-22.

(2) With engine idling, connect a jumper lead from generator F (field) terminal to ground on generator. This prevents regulator from controlling (or interfering with) generator output. A regulator defect will not now prevent operation of the generator.

(3) Slowly increase engine speed, while watching ammeter. If generator charging rate increases proportionally with engine speed to its rated output, generator is capable of satisfactory performance. Do not force generator to exceed normal output rating capacity of 30 amperes during this test.

(4) If output rises steadily to a value less than rated output then levels off or falls back, check for slipping fan belt. If generator does not pass test satisfactorily, replace generator.

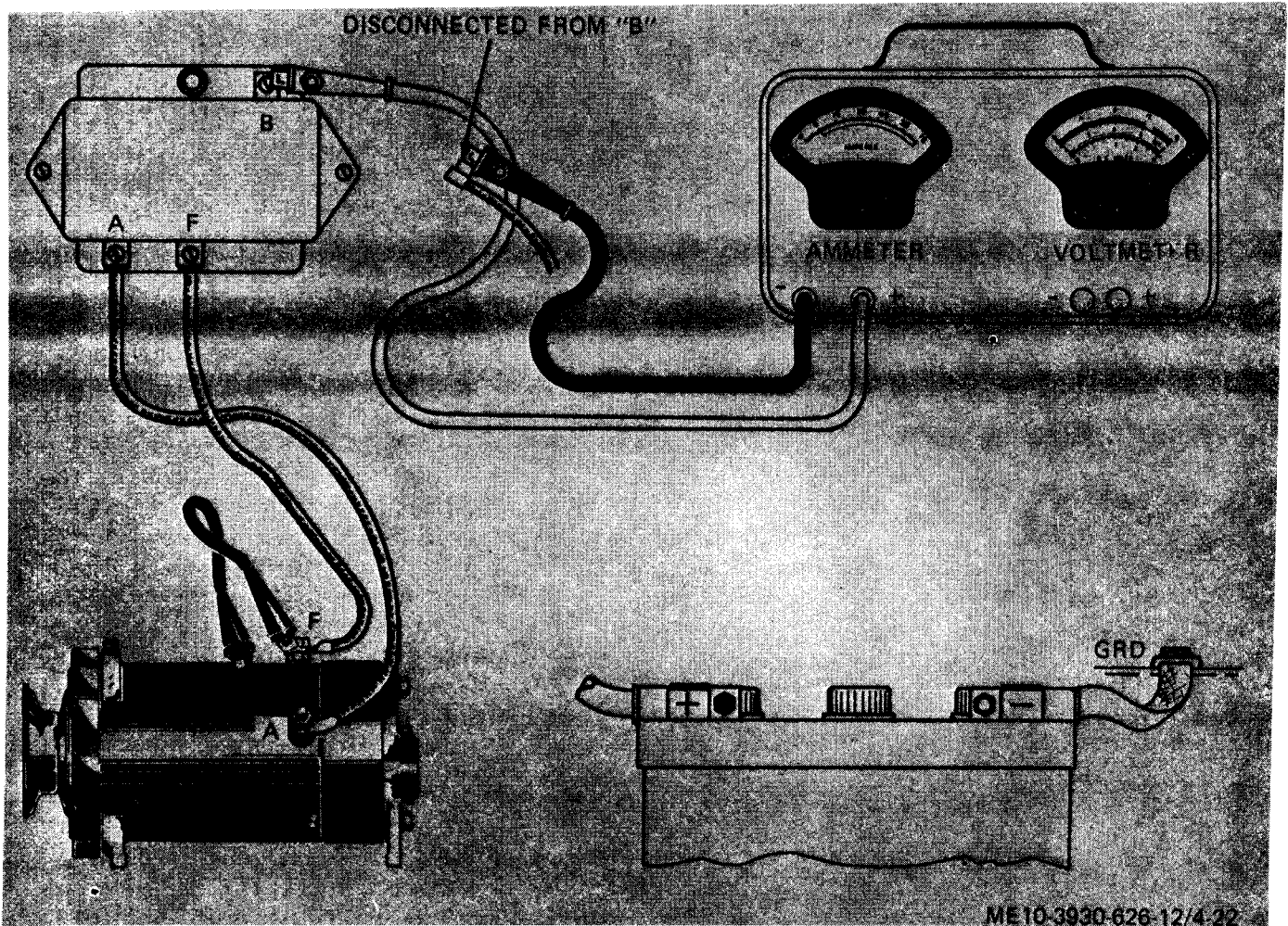

Figure 4-22. Hookup for generator output test.

##### b. Removal (fig. 4-11).

- (1) Open hood and remove panel from left side of engine compartment. *added see ch 3*
- (2) Disconnect and tag leads at generator terminals.
- (3) Remove screw which attaches capacitor to generator frame, and remove capacitor with lead attached.
- (4) Remove adjusting arm screw and washer.
- (5) Remove generator mounting bolts, nuts

and lock washers at underside of generator. Disengage generator from fan belt and remove generator.

##### c. Installation.

- (1) Reverse procedure in *b* above, tightening generator belt to  $\frac{1}{2}$  inch finger-pressure deflection midway between generator pulley and water pump pulley. *see ch 3*
- (2) ~~Rep~~ Repolarize generator, after all electrical connections have been made, by briefly shorting

together the BAT and ARM terminals of the generator regulator with a jumper wire, or a screwdriver blade, just long enough to cause a spark.

#### 4-47. Generator Regulator

##### a. General.

(1) Mechanical checks and adjustments (air gaps, point opening) must be made with battery disconnected and preferably with regulator off vehicle.

**Caution: Cutout relay contact points must never be closed by hand with battery connected to regulator. This would cause a high current to flow through the units which would seriously damage them.**

(2) Electrical checks and adjustments may be made either on or off vehicle if a test bench is available. Regulator must always be operated with generator for which it is designed.

**Caution: When removing and installing cover, exercise care to prevent touching cover on circuit breaker which would cause a short circuit and damage regulator assembly.**

(3) Regulator must be mounted in operating position when electrical settings are checked and adjusted and it must be at operating temperature. Operating temperature for regulator checking and adjusting is reached after 15 minutes of continuous operation of regulator with 1/4 ohm resistance in series with battery, and with regulator cover in place. It is not necessary to measure amount of current flowing during warm-up or testing of voltage unit, however, it is important that no electrical load other than ignition be turned on during test. (If a variable resistor is used in series with the battery, set to 10 amperes for warm-up period).

(4) Specified generator speeds for testing and adjusting.

(a) Voltage regulator: engine governed speed.

(b) Current regulator.

1. Generator must be operated at a speed sufficient to produce current in excess of specified setting.

2. Voltage of the generator must be kept high enough to insure sufficient current output, but below operating voltage of regulator unit.

(5) After any test of adjustments, generator on the vehicle must be polarized after leads are connected, but before the engine is started (para 4-46 c(2)). This allows a momentary surge of current to flow through generator which correctly polarizes it. Failure to do this may result in severe damage since reversed polarity causes vibration, arcing, and burning of relay contact points.

##### b. Removal.

(1) Open hood, remove panel from left side of engine compartment and open battery compartment door.

(2) Disconnect battery ground lead.

(3) Disconnect and tag leads from BAT, FLD, and ARM terminals at regulator.

(4) Remove three nuts, lockwashers, and screws that secure regulator and capacitor to left side panel and remove regulator and capacitor.

c. Installation. Reverse procedures in b above.

d. Testing and Adjusting. Prior to electrically testing the generator regulator, check and adjust the cutout relay armature air gap and contact point opening (subpara (1) (a) and (1) (b) below), and the voltage regulator armature air gap (subpara (2) (a) below) and the current regulator armature air gap (subpara (3) (a) below). Electrically test and adjust cutout relay before testing voltage and current regulator portions of generator regulator. With cutout relay operating properly, voltage regulator portion can be electrically tested and adjusted and finally current regulator portion can be electrically tested and adjusted.

(1) Cutout relay. The cutout relay requires three checks and adjustments, as follows:

(a) Air gap. With battery disconnected, measure air gap between armature and center of core (fig. 4-23). If adjustment is required, bend armature stop (fig. 4-24) up or down until correct air gap reading of 0.025 to 0.027 inch is obtained. Be certain armature stop does not interfere with armature alignment.



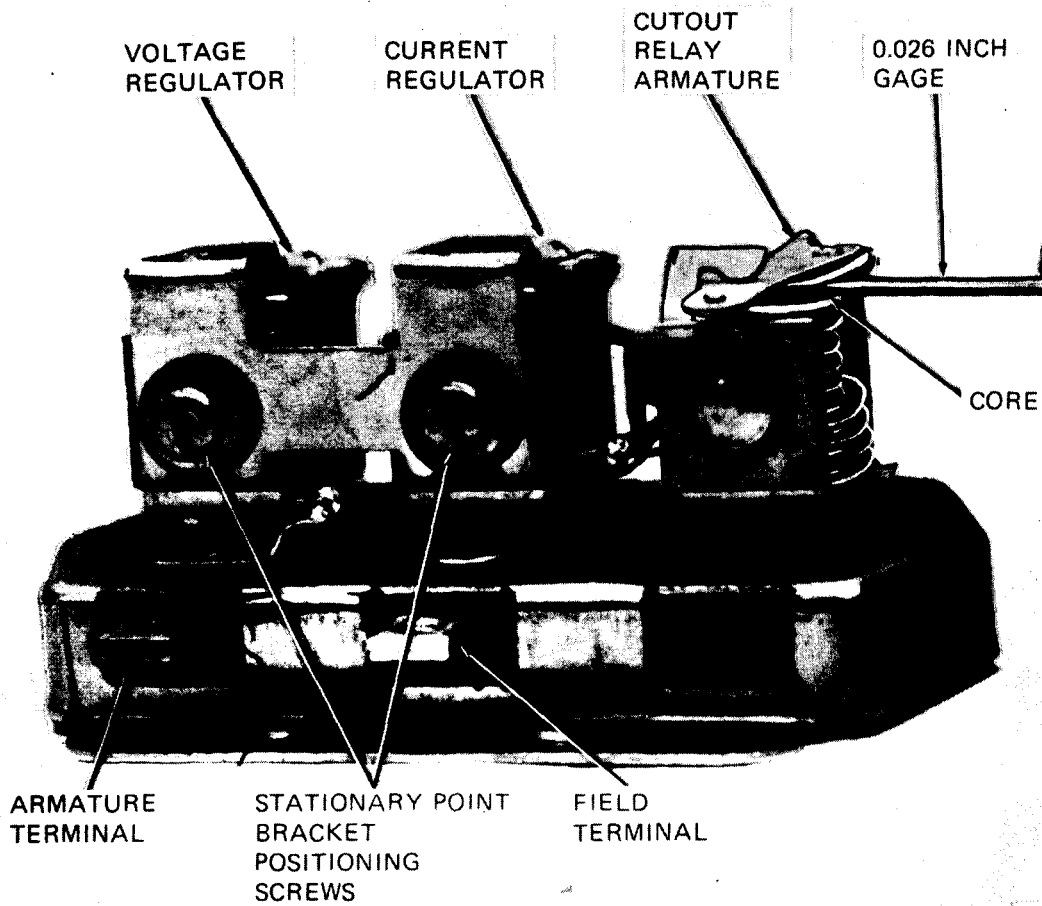

ME10-3930-626-12/4-23

Figure 4-23. Checking cutout relay armature air gap.

(b) Point opening. Adjust point opening to 0.015 inch by bending stationary contact support

(fig. 4-25). Be certain to keep contact points in alignment when adjusting contact gap.

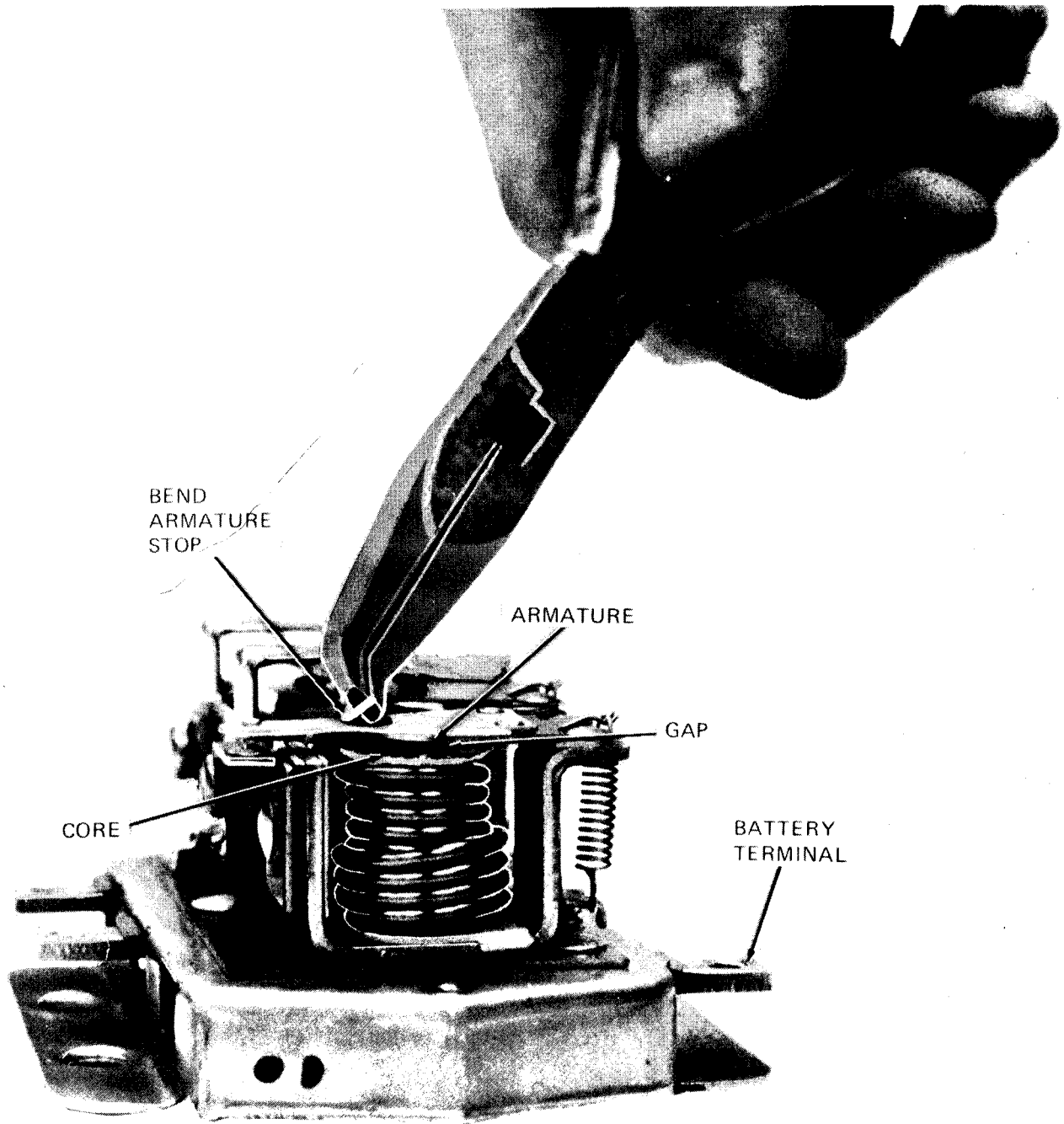

ME10-3930-626-12/4-24

*Figure 4-24. Cutout relay contact point gap adjustment.*

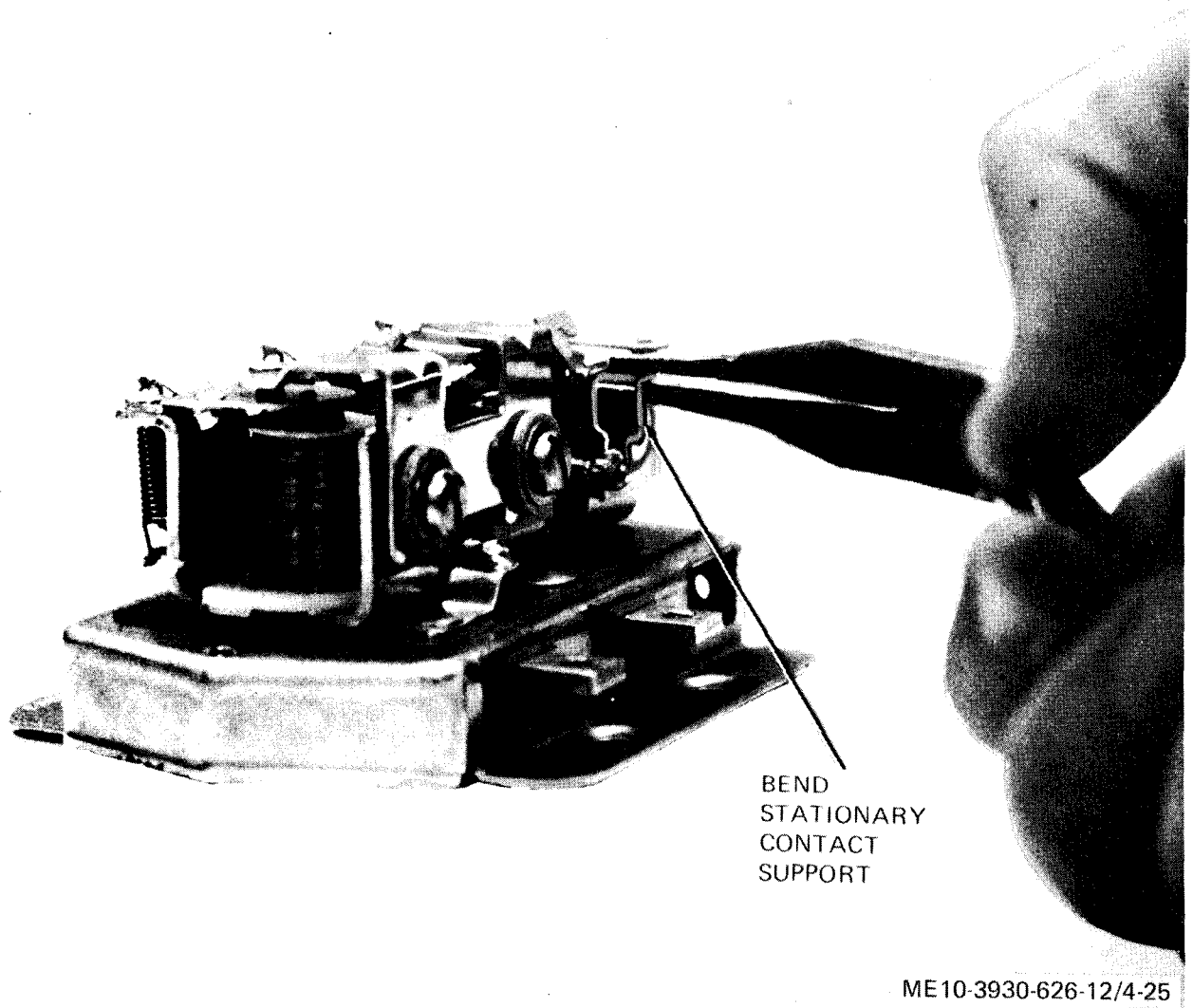

*Figure 4-25. Cutout relay armature air gap adjustment.*

(c) Electrical test.

1. Connect test equipment (fig. 4-26).

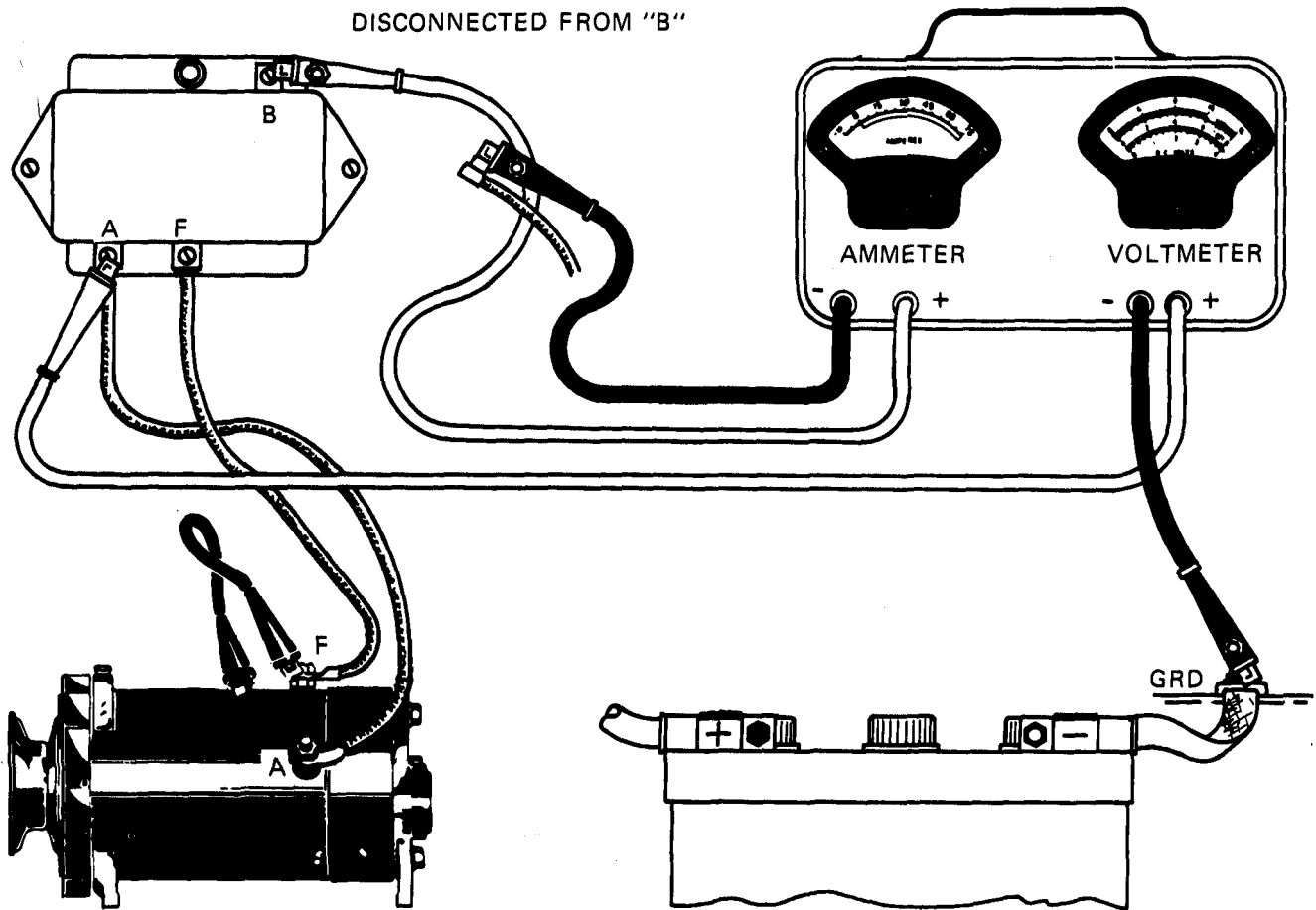

ME10-3930-626-12/4-26

Figure 4-26. Cutout relay test setup.

2. With engine running, regulator warmed up and battery fully charged, decrease engine speed until voltmeter reads less than battery voltage and ammeter reads steady on zero. Cutout relay points are now open.

3. Very slowly increase engine speed (by turning carburetor idle speed adjustment screw) so that voltmeter reading builds up a fraction at a time. Keep glancing at ammeter after each increase in voltage.

*Note.* Closing voltage of cutout relay is the highest voltmeter reading obtained just before ammeter pointer moves off zero. Closing voltage should be 12.6 to 13.6 volts.

4. Continue to increase engine speed until

ammeter reads 8 to 10 amperes, then slowly decrease speed while watching ammeter. Ammeter pointer will move to left of zero, then suddenly return to zero as speed is further decreased.

*Note.* Opening amperage of cutout relay is the greatest discharge reading obtained before pointer returns to zero. Opening amperage should be 3.0 to 5.0 amperes.

5. Repeat steps 3 and 4 several times to assure, an accurate test.

6. If closing voltage is not within limits, bend lower armature spring anchor (fig. 4-27). If opening amperage is not within limits, recheck point opening (subpara (1) b) above.

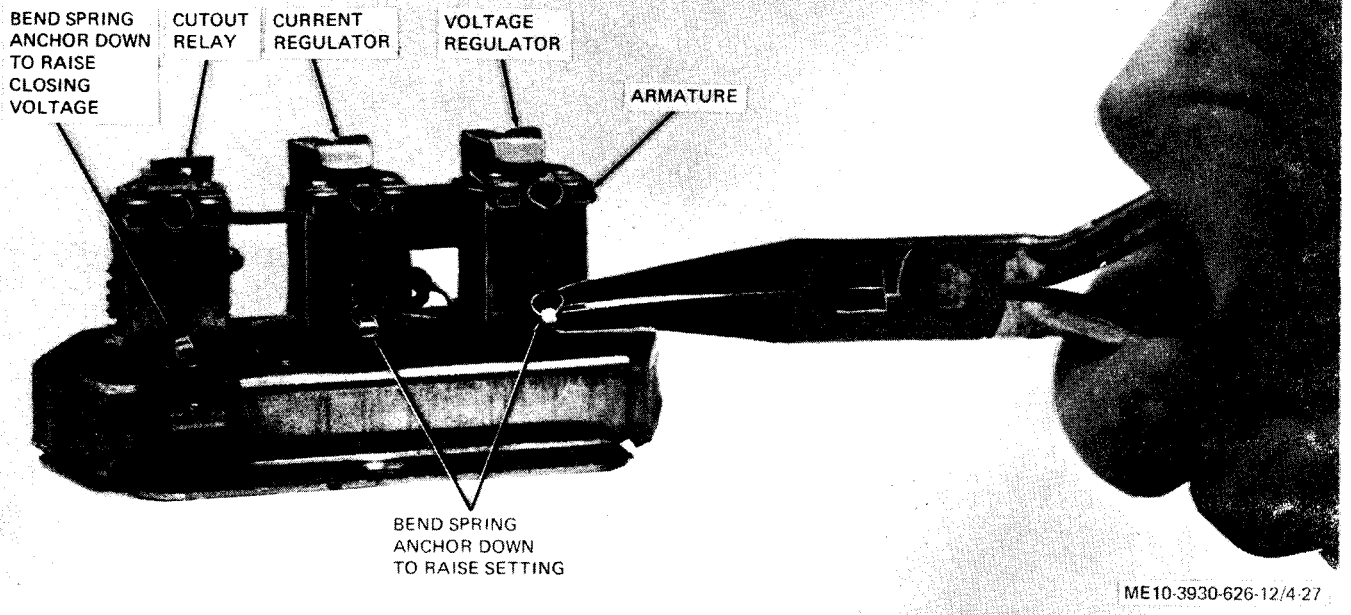
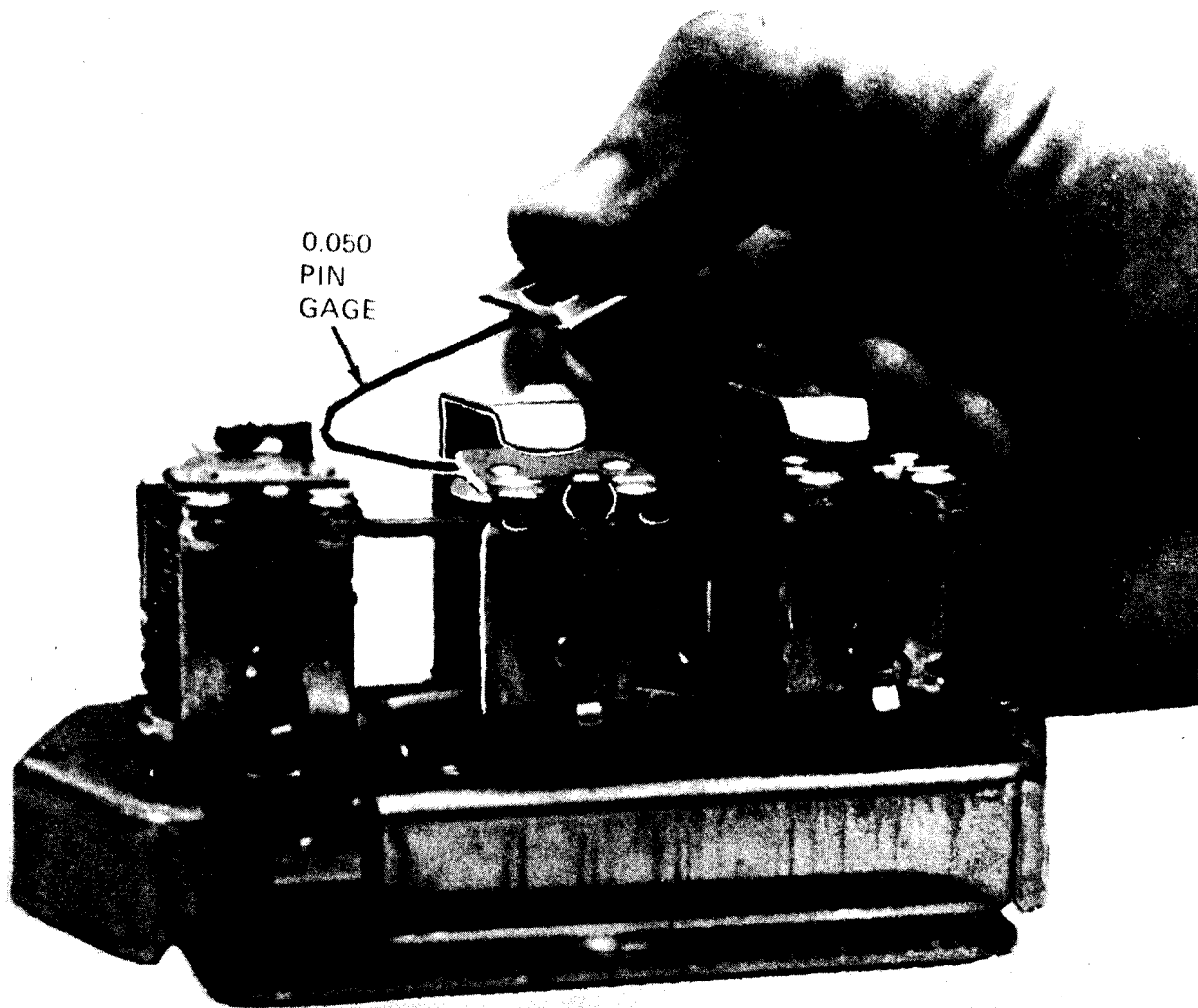

Figure 4-27. Spring anchor adjustment.

(2) *Voltage regulator.* The voltage regulator requires two checks and adjustments as follows:

(a) *Air gap.* With battery disconnected, check air gap (fig. 4-28). Insert gage on contact point side of air gap next to armature stop rivet. If adjustment is needed, loosen bracket adjustment

screw and raise or lower contact point bracket until a gap of 0.048 to 0.052 inch is obtained. Tighten bracket adjustment screw securely after making adjustment. When armature is held down so that stop rivet rests on magnet core, point gap should be a minimum of 0.012 inch.



ME10-3930-626-12/4-28

*Figure 4-28. Checking voltage and current regulator air gap.*

(b) *Electrical test.*

1. Connect test equipment (fig. 4-29).

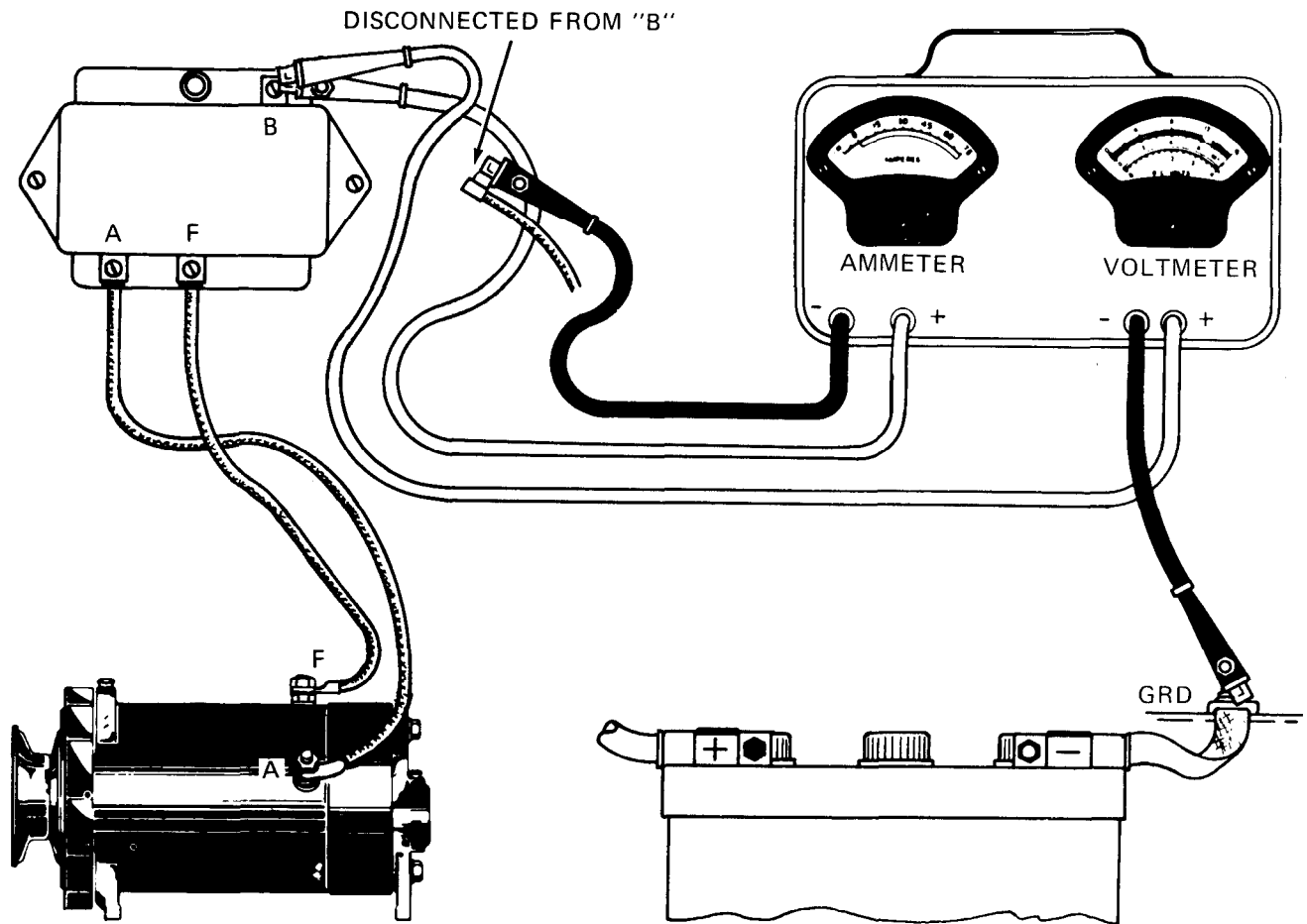

ME 10-3930-626-12/4-29

Figure 4-29. Voltage regulator test setup.

2. Run engine at 1500 rpm.

3. Turn on headlights and if necessary, apply load across battery until test ammeter reads approximately 7 amperes.

4. Cycle regulator by reducing speed until cutout relay points open, then slowly increase speed again to 1500 rpm.

5. Voltmeter reading indicator setting of voltage regulator unit. Reading should be 14.2 to 14.8 volts.

*Note.* Erratic voltmeter reading indicates burned, dirty or pitted contact points.

6. When adjusting voltage regulator, repeat steps 4 and 5 above after each adjustment and before taking final reading. Final test reading must be made with cover in place at normal operating temperature.

7. If voltage regulator is not within limits, bend lower armature spring anchor (fig. 4-27) to obtain proper voltage.

(3) *Current regulator.* The current regulator

requires two checks and adjustments as follows:

(a) *Air gap.* With battery disconnected, check air gap (fig. 4-27). Insert gage on contact point side of air gap next to armature stop rivet. If adjustment is needed, loosen bracket adjusting screw and raise or lower contact point bracket until a gap of 0.048 to 0.052 inch is obtained. Tighten bracket adjusting screw securely after making adjustment. When armature is held down so that stop rivet rests on magnet core, point gap should be a minimum of 0.012 inch.

(b) *Electrical test.*

1. Connect test equipment (fig. 4-30).

2. Run engine at 2000 rpm.

3. Apply a variable load across battery until ammeter reading is maximum.

4. Maximum ammeter reading indicates setting of current regulator unit. Reading should be 30 amperes.

*Note.* Erratic ammeter reading indicates dirty, burned or pitted contact points.

5. If current regulator is not within limits, obtain proper amperage.  
 bend lower armature spring anchor (fig. 4-27) to

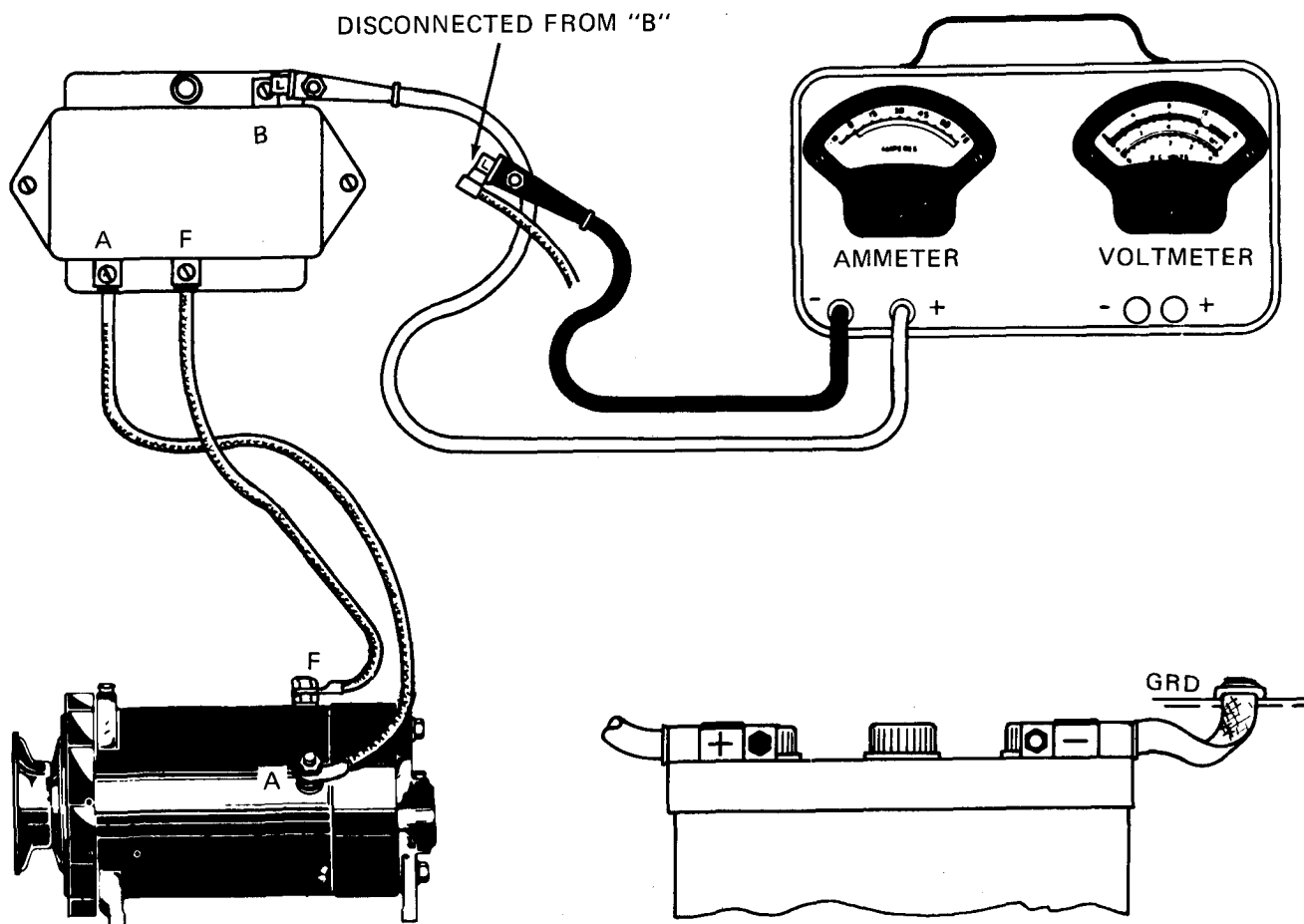

ME10-3930-626-12/4-30

Figure 4-30. Current regulator test setup.

#### 4-48. Starting Motor

a. Testing. Perform an operational test on  
 starting motor as follows:

- (1) Assure that battery is fully charged.
- (2) With ignition switch in OFF position, press starter button and hold for a few seconds.
- (3) While engine is cranking, listen for any unusual noises.

*Note.* If starting motor fails to crank engine, if operation is sluggish, or if unusual noises are evident, replace starting motor.

b. *Removal.*

- (1) Open battery compartment door and disconnect positive storage battery lead from storage battery.
- (2) Block up vehicle to a suitable working height.

(3) Disconnect storage battery lead from starter.

(4) Disconnect and tag two leads from starter to starter relay.

(5) Remove screw, nut and washers securing starter to transmission case and remove starter.

c. *Installation.* Reverse procedure in b above.

#### 4-49. Distributor

a. *Removal.*

(1) Loosen nut and washers at distributor primary terminal (fig. 4-31) and remove primary circuit lead-in wire.

(2) Snap spring clips from distributor cap and lift cap from distributor. Do not remove wires from cap.

Approved by ch3



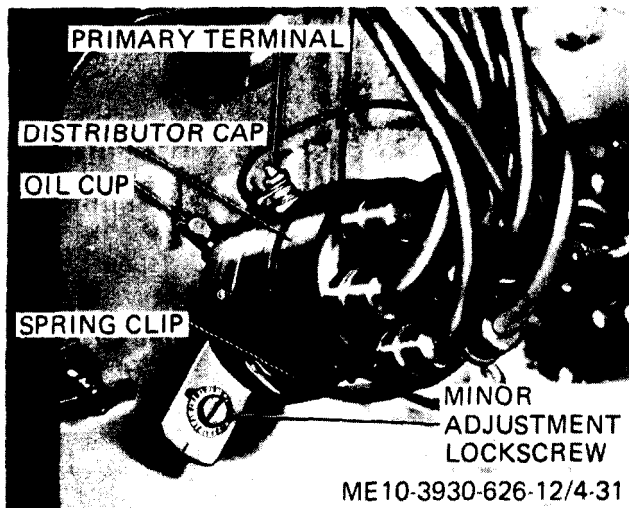

Figure 4-31. Distributor, installed.

(3) Chalk mark edge of distributor to indicate location of rotor tip before removal, loosen minor adjustment lock screw and lift out distributor.

*Note.* Do not turn engine crankshaft until distributor is reinstalled.

*b. Inspection.*

(1) Inspect distributor cap for cracks, carbon streaks, corroded terminals and dirt.

(2) Inspect contact points (fig. 4-32). Be sure they are free of burns or pits, are aligned correctly and are adjusted properly to 0.018 to 0.022 inch. Follow adjustment procedure in *d* below.

(3) Inspect rotor and the metal contact strip for burned condition or cracks.

(4) Inspect capacitor for secure mounting and frayed lead.

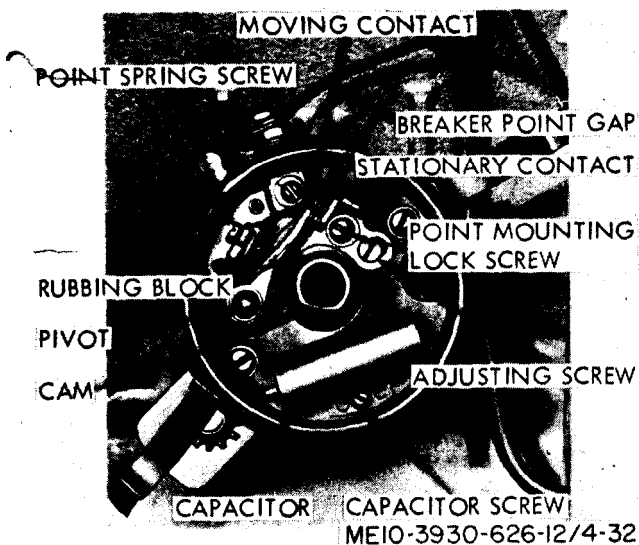

Figure 4-32. Distributor, cap removed.

*c. Repair.*

(1) If contacting area of points is slightly burned or pitted, clean area with a few strokes of a point file. Do not try to remove all roughness, or dress points down smoothly; only remove scale or dirt. Do not use sandpaper or emery to dress points.

(2) To remove points, remove the point mounting lock screw and point spring screw and lift off point set. To remove capacitor at this time remove capacitor screw and lift capacitor from distributor.

*Note.* Do not replace capacitor unless it is ~~believed to be~~ defective. *Also check*

(3) Install points and capacitor by reversing (2) above.

(4) Test automatic advance by twisting cam clockwise. It should turn against spring tension, and return by spring tension to its original position.

*d. Adjustment.*

(1) Turn cam until rubbing block on moving point arm rests on peak of one cam lobe (fig. 4-32).

(2) Loosen point mounting lock screw, and adjust position of stationary contact, with adjusting screw, until 0.018 to 0.022 inch leaf feeler gage will just enter gap,

(3) Tighten point mounting lock screw.

(4) Turn cam until contact points are completely closed. Hook a spring scale on moving contact (fig. 4-33) and pull in a straight line at a right angle to point surfaces. Take a reading as points start to separate under a slow and steady pull. Spring tension should be 17 to 20 ounces.

(5) If necessary to adjust spring tension, loosen point spring screw (fig. 4-32) which holds end of moving contact spring and slide end of spring in or out, as necessary. Tighten point screw and recheck spring tension.

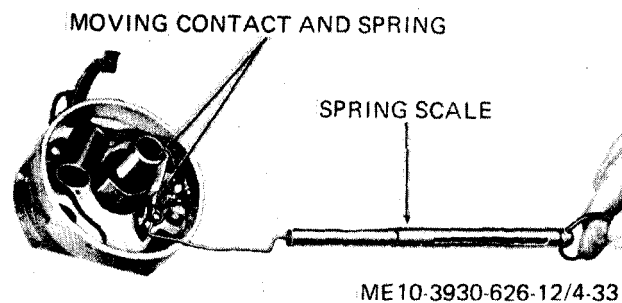

Figure 4-33. Testing moving contact spring tension.

*e. Installation of Distributor and Adjustment of Engine Timing.*

(1) Position rotor so tip points to chalk mark made in a (3) above, and replace distributor in engine. Connect primary lead wire. Do not install distributor cap.

~~(2) Tighten distributor minor adjustment lock screw (fig. 4-31) only enough to put a drag on distributor body if turned. Turn engine until scribed mark on crankshaft pulley is aligned with pointer on gear case cover.~~

(3) Turn distributor body clockwise until points are definitely closed.

(4) Turn on ignition, remove coil wire from center of distributor cap and hold it about 1/4 inch from cylinder head.

(5) Turn distributor slowly counterclockwise, stopping at exact point at which coil wire sparks. Tighten minor adjustment lock screw, turn off ignition and reinstall distributor cap and coil wire in cap.

#### 4-50. Ignition Coil

*a. Testing.* The following procedure describes a quick test to determine that ignition coil is in good condition. Assure that all electrical connections are properly made before performing test.

(1) Remove coil to distributor high tension lead from center socket contact in distributor cap.

(2) Hold end of lead approximately 1/4 inch from cylinder head while an assistant cranks engine with ignition on.

(3) Check that sparks jump at least 1/4 inch. Replace coil if test requirements are not met.

##### *b. Removal.*

(1) *Tag* and disconnect leads at stud type terminal on ignition coil (fig. 4-6).

(2) Pull high tension lead out of socket terminal on ignition coil.

(3) Remove two screws securing coil strap to coil bracket, and withdraw coil and strap from engine compartment.

(4) Loosen screw in coil strap and slide coil free from strap.

*c. Installation.* Reverse removal procedure in *b* above.

#### 4-51. Battery and Cables

##### *a. Removal.*

(1) Open battery compartment door.

(2) Disconnect ground cable (6, fig. 4-34) and starter cable (1) at battery (5). If necessary use a puller to lift cable terminals from posts with a vertical pull. Do not twist or pry terminals from post.

(3) Remove nut (8) and screw (7), and disconnect ground cable from frame. Disconnect starter cable from starter and pull through grommet (10) in frame.

(4) Loosen and remove nuts (2) and washers (3) from bolts (9) and remove battery hold-down (4). Lift battery clear of truck.

**Caution: Avoid contact with any liquid on the battery. It will probably be electrolyte, which can produce skin burns and damage clothing if not rinsed off quickly with clear water.**

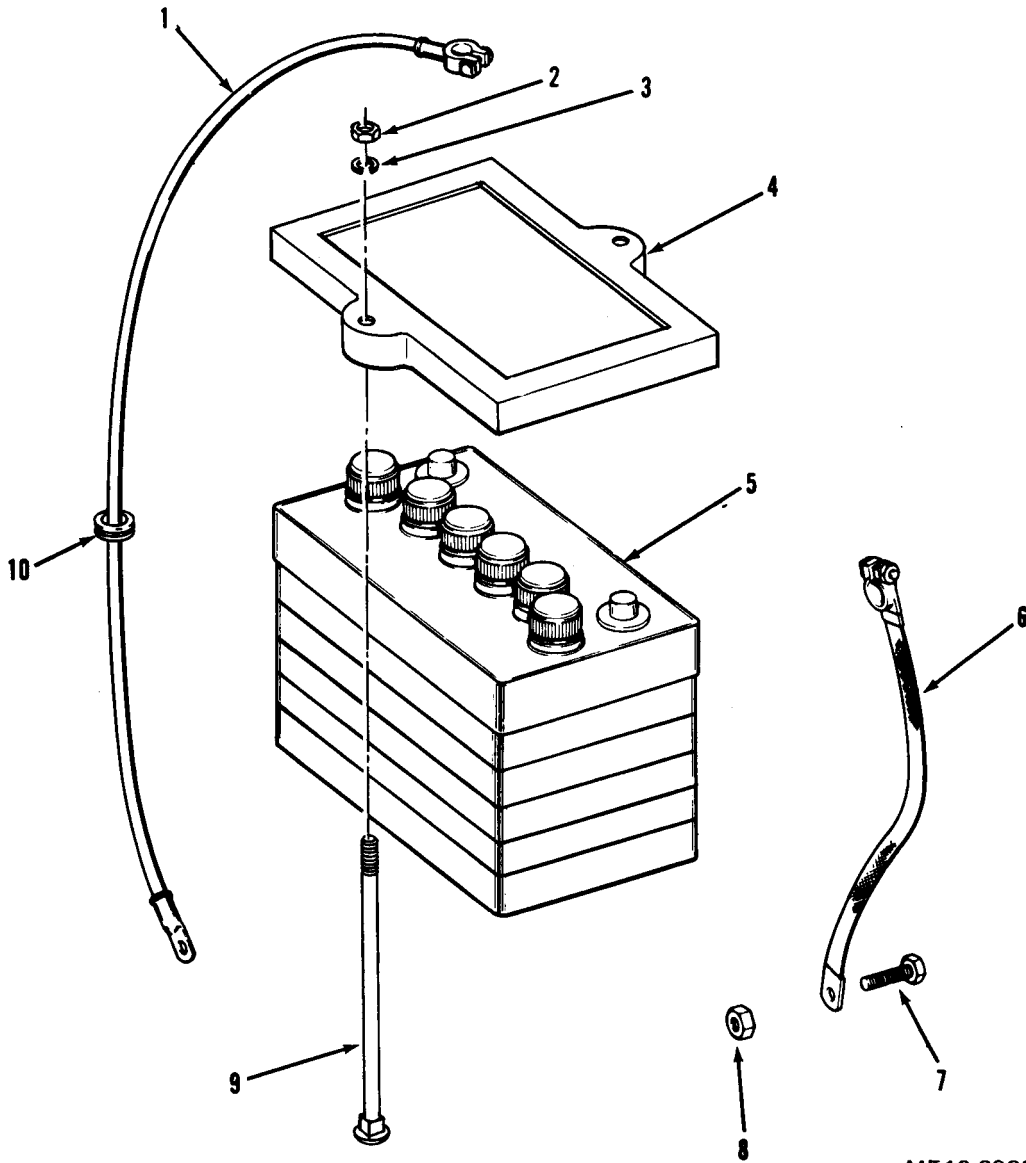

ME10-3930-626-12/4-34

1. Starter cable
2. Nut
3. Flat washer
4. Battery hold-down
5. Battery
6. Ground cable
7. Screw
8. Nut
9. Bolt
10. Grommet

Figure 4-34. Battery and cables.

*b. Cleaning.*

(1) Wash battery by flushing freely with water. Use brush if necessary to remove crusted deposits. Brush terminal posts to bright finish without removing metal.

(2) Wash battery cables in hot water to, remove dirt and corrosion, Wire brush inside of battery terminals to bright finish. *1. Added work*

*c. Installation.* Reverse *a* above. Tighten battery hold-down nuts (2) only tight enough to hold battery snugly. Do not over tighten.

*d. Test.*

(1) Remove cell caps, and test specific gravity of electrolyte in each cell with battery hydrometer. All cells should read within 10 points of each other. Reading of 1.275 to 1.300 indicates full charge; 1.220 to 1.225 indicates about 50 percent charged; 1.160 indicates practically complete discharge. Variations in readings among cells indicate the low reading cells are defective, and battery must be replaced.

*4-51.1 para added*

*See ch 3*

*Note.* Readings above apply at electrolyte temperature of 80° F. At different temperatures, add 0.004 to reading for each 10° F. above 80° F; subtract 0.004 from actual reading for each 10° F. below 80° F. to obtain value for comparison with figures given. In case of chronic low state of charge, refer condition to higher maintenance for charging system service.

(2) With fully charged battery installed, test cables and connections as follows:

(a) Contact positive battery post (do not touch cable terminal) with positive lead of voltmeter calibrated in tenths of a volt. Contact negative voltmeter lead to starter terminal of starter.

(b) Crank engine. Note voltmeter reading while cranking. Any reading in excess of 0.2 volt indicates electrical resistance due to a bad cable or connection.

(c) Repeat (a) and (b) above, except contact ground on engine with voltmeter positive lead, and voltmeter negative lead touching battery negative post. Voltmeter reading greater than 0.2 volt indicates bad cable or connection.

## Section XIV. UNIVERSAL JOINTS

### 4-52. General

A propeller shaft containing a universal joint is used to connect the transmission to the input pinion on the drive axle. The propeller shaft has a slip spline section which facilitates removal and installation of the shaft.

### 4-53. Replacement of Universal Joints

*a. Removal.*

(1) Remove screws and lock plates (fig. 4-35) securing trunnion bearings to flange at rear of transmission and at flange on rear axle drop gear case.

(2) Slide two sections of propeller shaft together along splined section and withdraw propeller shaft with two crosses from between transmission and drop gear case.

(3) Remove screws and lock plates securing trunnion bearings to flanges on both ends of propeller shaft. Separate trunnion bearings and crosses from propeller shaft flanges.

(4) Remove rollers from trunnion bearings.

(5) Remove seals and seal retainers from both crosses.

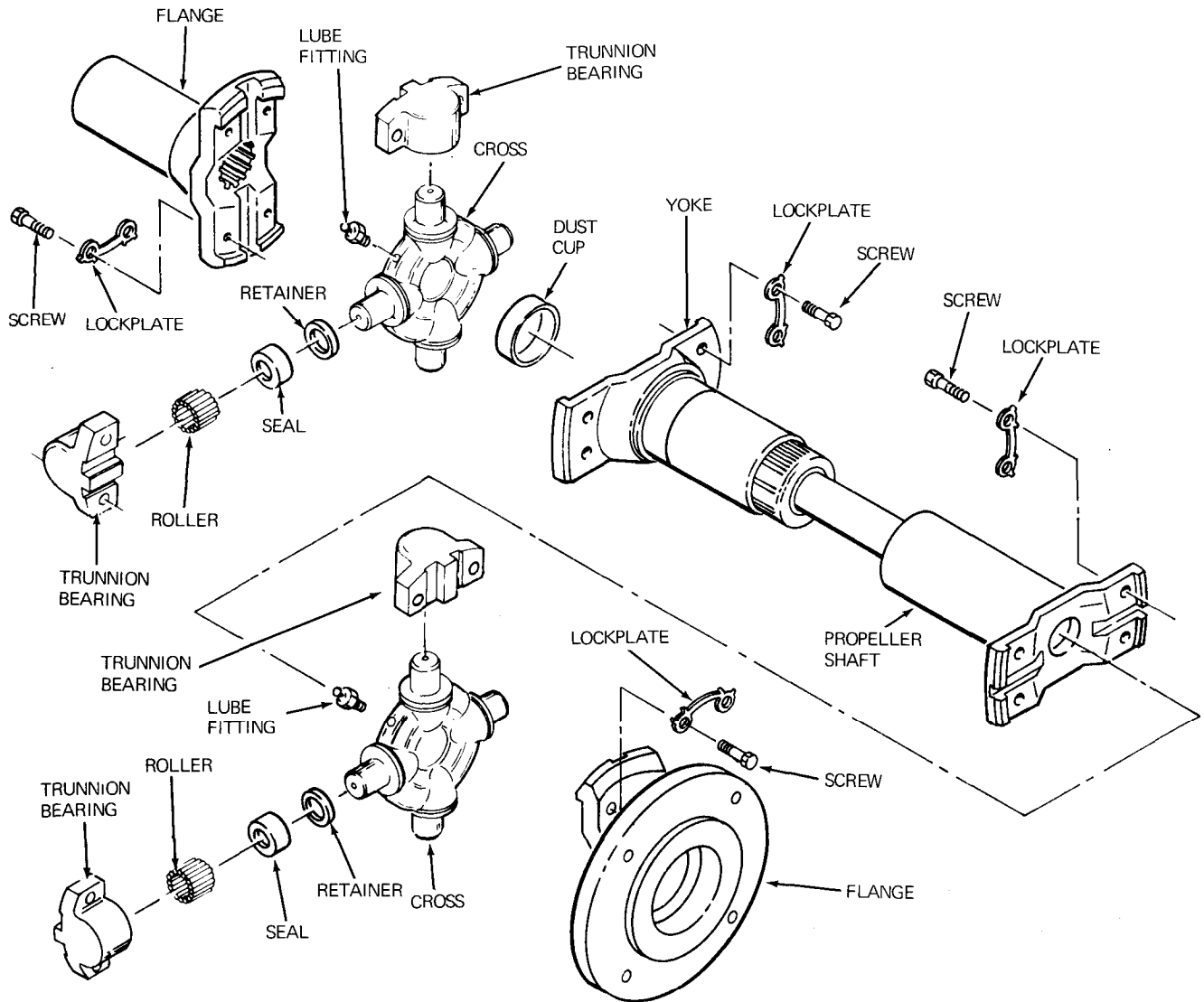

ME 10-3930-626-12/4-35

Figure 4-35. Propeller shaft.

b. *Installation.* Reverse procedure in a above, installing new seals. Coat rollers in trunnion bearings with GAA grease. Lubricate in accordance

with lubrication order after installation is completed.

## Section XV. BRAKES

### 4-54. General

a. The tractor contains a hand (parking) brake which operates on a drum at the rear end of the transmission and service brakes which are effective at the rear drive wheels.

b. This section contains instructions for maintenance operations which organizational maintenance personnel are authorized to perform on handbrake and linkage, service brakes, master cylinder, and wheel cylinders.

### 4-55. Parking Brake, Parking Brake Lever and Linkage

#### a. Parking Brake Lever and Linkage.

(1) *Adjustment.* Pull up parking brake lever and test holding power of parking brake on an incline. If parking brake does not hold, turn cap on parking brake lever clockwise and test it again. Continue this process until proper adjustment is obtained. When cap is overadjusted, parking brake lever will not lock in an upright (locked) position.

(2) *Removal.*

(a) Remove rear floor plate from tractor chassis.

(b) Release parking brake lever and remove two nuts (2, fig. 4-36) and screws (11). Remove parking brake (1) from body panel.

(c) Back off adjusting nuts (9) on parking brake cable (10),

(d) Remove parking brake cable clamping screw (5), nut (3) and washer (4).

(e) Remove adjusting screw cover plate (15, fig. 4-37) and disengage ball end of parking brake cable from operating lever (18).

(f) Remove inner washer (6, fig. 4-35), boot (7) and outer washer (8) from parking brake cable (10) and remove parking brake with attached cable from tractor.

(3) *Cleaning and inspection.*

(a) Clean all parts with SD and dry thoroughly.

(b) Inspect all parts for wear, breaks and other damage. Check parking brake lever for free operation and stripped threads on cap. Inspect cable for kinks, freedom of movement and security of ball attachment at end of cable.

(c) Replace all unserviceable parts.

(4) *Installation.* Reverse procedure in (2) above. Cable length adjusting nut (9) should be positioned against cable housing so that clearance of 0.005 to 0.0010 inch exists between parking brake cable (10) and lever (18, fig. 4-37). Adjust parking brake as described in (1) above.

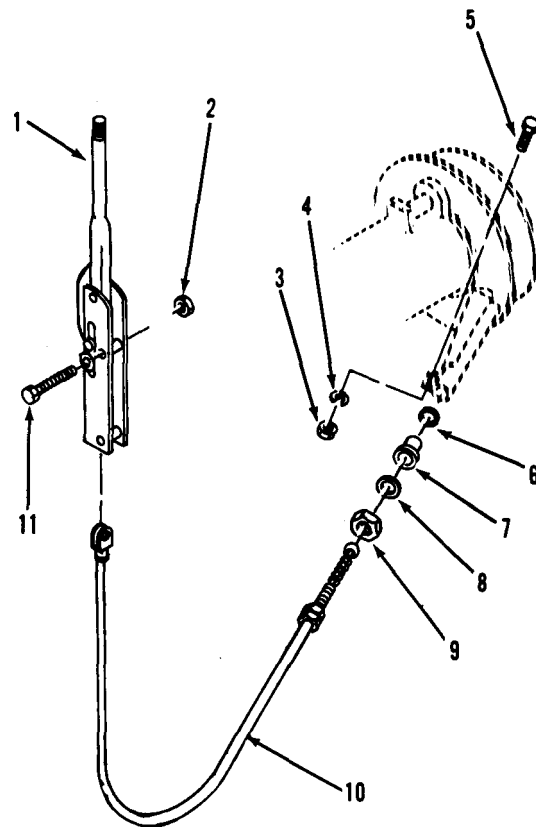

ME10-3930-626-12/4-36

- |                        |                   |
|------------------------|-------------------|
| 1. Parking brake lever | 7. Boot           |
| 2. Nut                 | 8. Outer washer   |
| 3. Nut                 | 9. Adjustment nut |
| 4. Lock washer         | 10. Cable         |
| 5. Screw               | 11. Screw         |
| 6. Inner washer        |                   |

Figure 4-36. Parking brake lever and cable, exploded view.

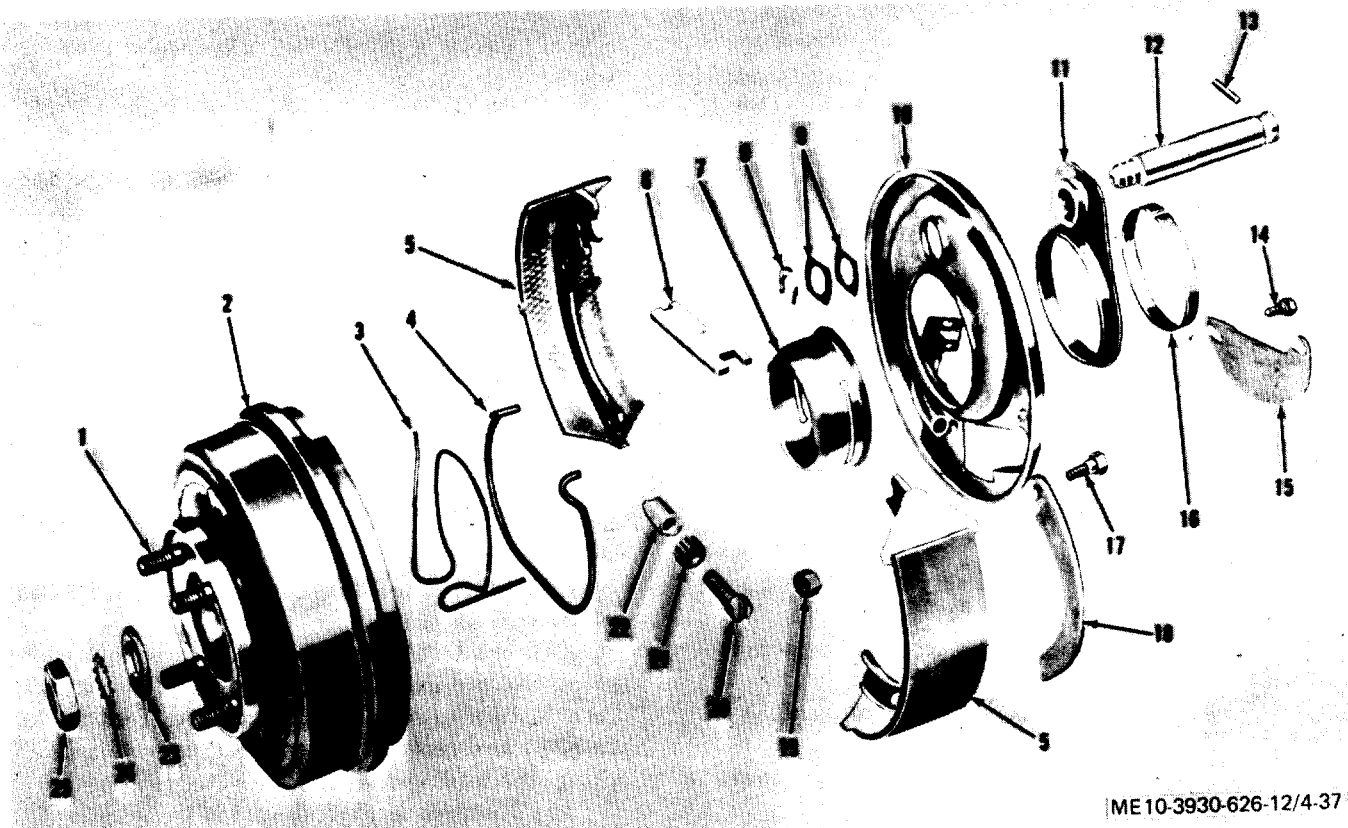

- 1. Stud
- 2. Brake drum
- 3. Spring retainer
- 4. Return spring
- 5. Brake shoe
- 6. Operating lever strut
- 7. Shield
- 8. Guide retainer
- 9. Guide
- 10. Support
- 11. Spacer
- 12. Anchor
- 13. Pin

- 14. Screw
- 15. Adjustment cover plate
- 16. Sleeve
- 17. Screw
- 18. Lever
- 19. Nut
- 20. Adjustment screw
- 21. Adjustment nut
- 22. Sleeve
- 23. Washer
- 24. Washer
- 25. Nut

Figure 4-37. Parking brake, exploded view.

**b. Parking Brake,**

**(1) Adjustment.**

(a) Remove rear floor plate from tractor chassis.

(b) Release parking brake lever.

(c) Remove screw (14, fig. 4-37) and adjusting screw cover plate (15).

(d) Turn adjusting nut (21) until brake shoes (5) fully contact brake drum (2).

(e) Back off adjusting nut six notches.

*c* Note. Be certain two raised shoulders on adjusting nut are seated in grooves on adjusting sleeve (22).

(f) Apply parking brake lever and adjust as described in paragraph 4-55a(1) above. If parking brake lever cap adjustment is exceeded, readjust

adjusting nut (21) one notch at a time until parking brake lever can be properly adjusted.

(g) Replace cover plate (15) and screw (14).

**(2) Shoe removal.**

(a) Raise rear end of vehicle until rear tires clear floor. *use block about 2' x 3'*

(b) Remove propeller shaft as described in paragraph 4-53 a.

(c) Remove nut (25, fig. 4-37), and washers (24 and 23) securing brake drum (2), and with parking brake lever released, remove brake drum.

(d) Disengage ball end of parking brake cable from level (18).

(e) Separate brake shoes (5) at bottom

releasing adjusting nut (21), screw (20) and sleeve (22).

(f) Pry off brake return spring retainer (3) from shield (7) and remove brake return spring (4).

(g) Remove brake shoe retainer (8) and other guide (9) from anchor (12).

(h) Remove brake shoes (5) from support plate (10). Operating lever strut (6) will fall out as brake shoes are removed.

(i) Separate operating lever (18) from brake shoe by removing nut (19), washer and screw (17).

(j) Spacer (11), sleeve (16), shield (7) and anchor (12) need not be removed from support (10).

(3) *Shoe installation.*

(a) Reverse procedure in (2) above.

(b) Turn adjusting nut (21) until brake shoes are in released position before installing brake drum (2).

(c) Be certain brake shoes are centered on support and are free to move.

(d) Adjust brake shoes (subpara b (1) above).

(e) Adjust parking brake lever (subpara a (1) above).

#### 4-56. Service Brake Shoes and Wheel Cylinders

*a. Adjustment.*

(1) Raise rear end of tractor until rear tires clear floor. *and securely block (both)*

(2) Turn adjusting bolt with a 15/16 inch open end wrench (fig. 4-38) until a slight drag can be felt as the wheel is turned by hand.

(3) Back off adjusting bolt until wheel can rotate freely.

(4) Repeat adjustment for all four brake shoes and test brakes.

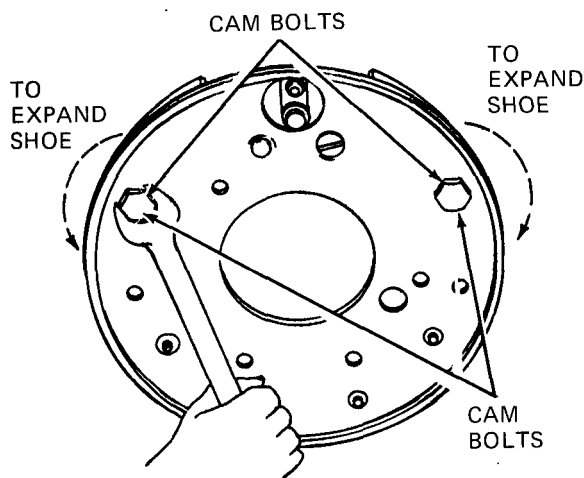

ME10-3930-626-12/4-38

Figure 4-38. Brake adjustment.

*b. Inspection.*

<sup>62</sup> (1) Remove wheels with assembled tires (para 4-60)

(2) Back off brake shoe adjusting bolts and remove brake drums.

(3) Inspect thickness of lining on brake shoes. Replace shoes if lining is less than 1/16 inch thick at thinnest point.

(4) Inspect wheel cylinders for leakage or cracked or deteriorated boots. Replace cylinder if defective. *b.1. added see ch 3*

*c. Removal.*

(1) Remove wheels with assembled tires and tubes paragraph 4-62 a.

(2) Back off brake shoe adjusting bolts and remove brake drum.

(3) Clamp wheel cylinder pistons to prevent loss of fluid, or air entering brake lines.

(4) Remove retainer (36, fig. 4-39), and brake return spring (35).

(5) Hold retainer (5) from turning, depress spring (6) and grasp antirattle rod (7) with a pliers. Turn 1/4 turn to release antirattle rod from backing plate (8) and remove inner and outer retainers (5), spring (6) and antirattle rod (7).

(6) Remove brake shoes (34).

Note. Remove wheel cylinder as described below only if inspection shows that replacement is necessary.



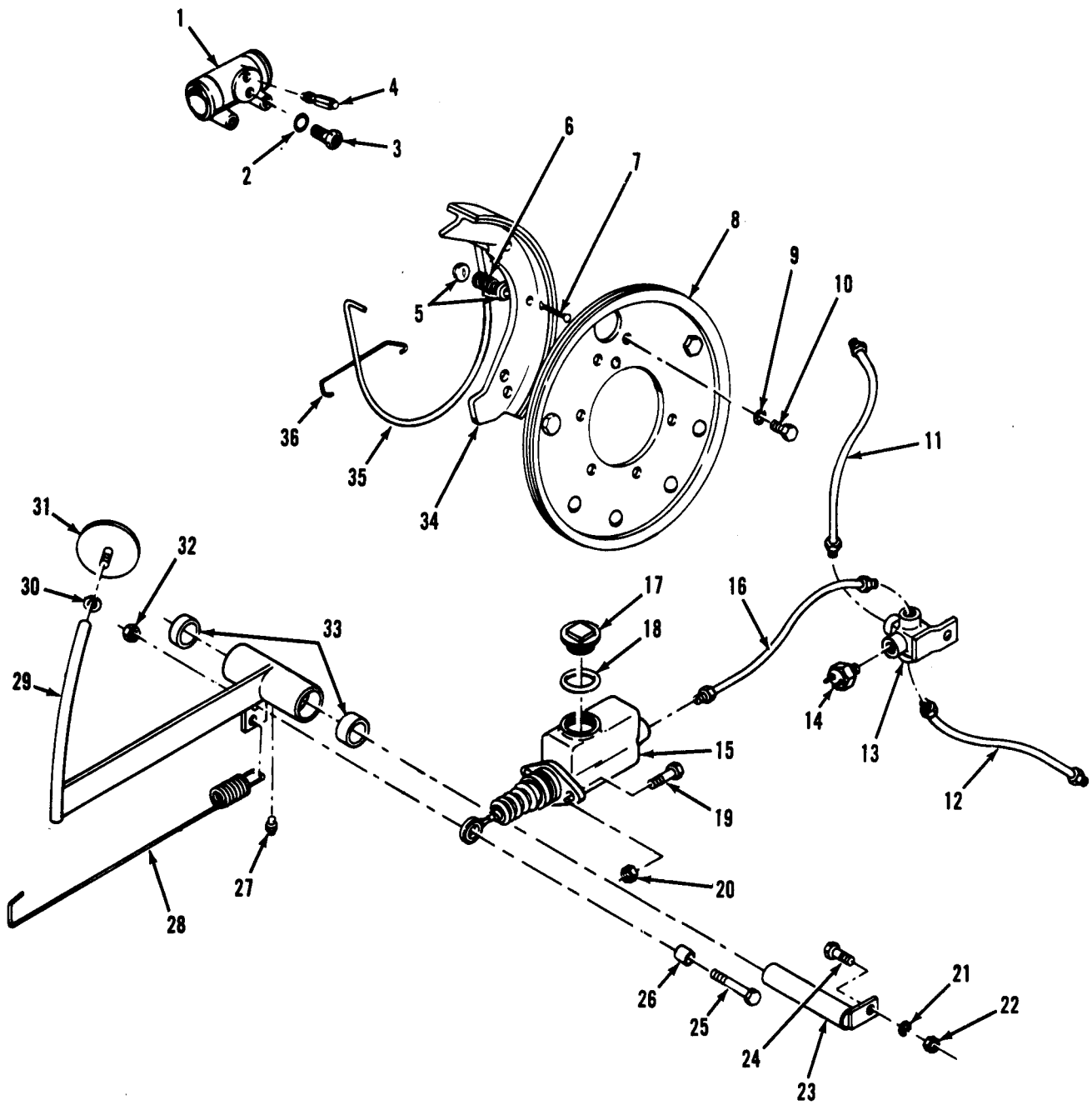

ME10-3930-626-12/4-39

- |                         |                           |                         |
|-------------------------|---------------------------|-------------------------|
| 1. Brake wheel cylinder | 13. Brake line tee        | 25. Eccentric bolt      |
| 2. Washer               | 14. Stoplight switch      | 26. Sleeve bearing      |
| 3. Inlet bolt           | 15. Brake master cylinder | 27. Lubrication fitting |
| 4. Bleeder screw        | 16. Brake line            | 28. Pedal return spring |
| 5. Retainer             | 17. Filler plug           | 29. Brake pedal         |
| 6. Spring               | 18. Washer                | 30. Lock washer         |
| 7. Antirattle rod       | 19. Screw                 | 31. Pedal pad           |
| 8. Backing plate        | 20. Nut                   | 32. Nut                 |
| 9. Washer               | 21. Washer                | 33. Sleeve bearing      |
| 10. Screw               | 22. Nut                   | 34. Brake shoe          |
| 11. Brake line          | 23. Brake pedal shaft     | 35. Brake return spring |
| 12. Brake line          | 24. Screw                 | 36. Retainer            |

Figure 4-39. Brake system, exploded view.

(7) Disconnect brake lines (11 and 12) from inlet bolts (3) and catch escaping hydraulic brake fluid in a container. Remove inlet bolts (3) and washers (2). Do not reuse brake fluid.

(8) Remove two screws (10) and washers (9) securing brake wheel cylinder (1) and remove brake wheel cylinder from backing plate (8).

*d. Installation.* Reverse procedure in *c* above. Bleed brakes (para 4-57d). Adjust brakes as described in *a* above.

#### 4.57. Brake Master Cylinder

##### *a. Inspection.*

- (1) Inspect for secure mounting and leaks.
- (2) Check boot for deterioration.
- (3) Check for adequacy of fluid.

##### *b. Removal.*

(1) Remove rear floor plate from tractor chassis.

(2) Disconnect brake line (16, fig. 4-39) from brake master cylinder (15) and catch any escaping brake hydraulic fluid in a container. Do not reuse fluid.

(3) Remove nut (32), eccentric bolt (25) and push rod bushing (26).

(4) Remove two nuts (20) and screws (19) securing brake master cylinder (15) and remove brake master cylinder.

*c. Installation.* Reverse procedure in *b* above, and bleed brake lines (*d* below) if any appreciable amount of hydraulic brake fluid escaped when the brake master cylinder was removed.

*d. Bleeding Brakes.* Bleed brakes whenever hydraulic brake fluid lines have been disconnected

at wheel cylinder or any appreciable quantity of fluid escapes at brake master cylinder removal.

(1) Remove filler plug (17) and washer (18) and make certain master cylinder is filled with hydraulic brake fluid, Refill as required during brake bleeding.

(2) Connect hose between bleeder screw (4) of wheel cylinder (1) and a container which holds a small amount of brake fluid.

(3) Depress brake pedal (31) slowly and open bleeder screw. Just before brake pedal is completely depressed, close bleeder screw. Release brake pedal.

(4) Repeat instructions in (3) above three or four times, or until bubbles cease to appear in container. Close bleeder screw and disconnect hose.

(5) Repeat procedures in (2) through (4) above on wheel cylinder of other drive wheel.

#### 4-58. Service Brake Pedal Adjustment

~~a. Unscrew pedal pad (31) from brake pedal (29).~~

b. Remove accelerator pedal from front floor plate (para 4-40 a).

c. Remove front floor plate.

d. Remove pedal return spring (28, fig. 4-39), to more easily feel range of free pedal.

e. Loosen nut (32) and turn eccentric bolt (25) until  $\frac{3}{8}$  to  $\frac{5}{8}$  inch free travel is obtained at pedal pad end of brake pedal (29).

f. Lock eccentric bolt in place with nut (32).

g. Install front floor plate.

~~h. Reinstall accelerator pedal and brake pedal pad.~~

*Superior lock*

*See ch 3*

## Section XVI. WHEELS, TIRES, AND WHEEL BEARINGS AND SPRINGS

#### 4-59. General

This section contains instructions for maintenance operations which organizational maintenance personnel are authorized to perform on the (rear) driving wheels and tires, front wheels and tires, inner tubes, and front wheel bearings, and front leaf springs.

#### 4-60. Front Wheels and Bearings

##### *a. Removal.*

(1) Block tractor securely and jack front wheels off ground.

(2) Remove six screws (16, fig 4-40) and

washers (15) securing grease cap (14) and remove grease cap and gasket (13).

(3) Bend up sides of lock (19) that secures adjusting nuts (7) to spindle (1).

(4) Remove adjusting nuts (7), lock (19), key washer (6), and outer bearing cone (2).

(5) Remove wheel (10) with assembled hub (20), tire (11), and tube from spindle.

(6) Remove inner bearing cone (2) and oil seal (21) from spindle (1).

(7) Remove inner and outer bearing cups (3) from hub (5).

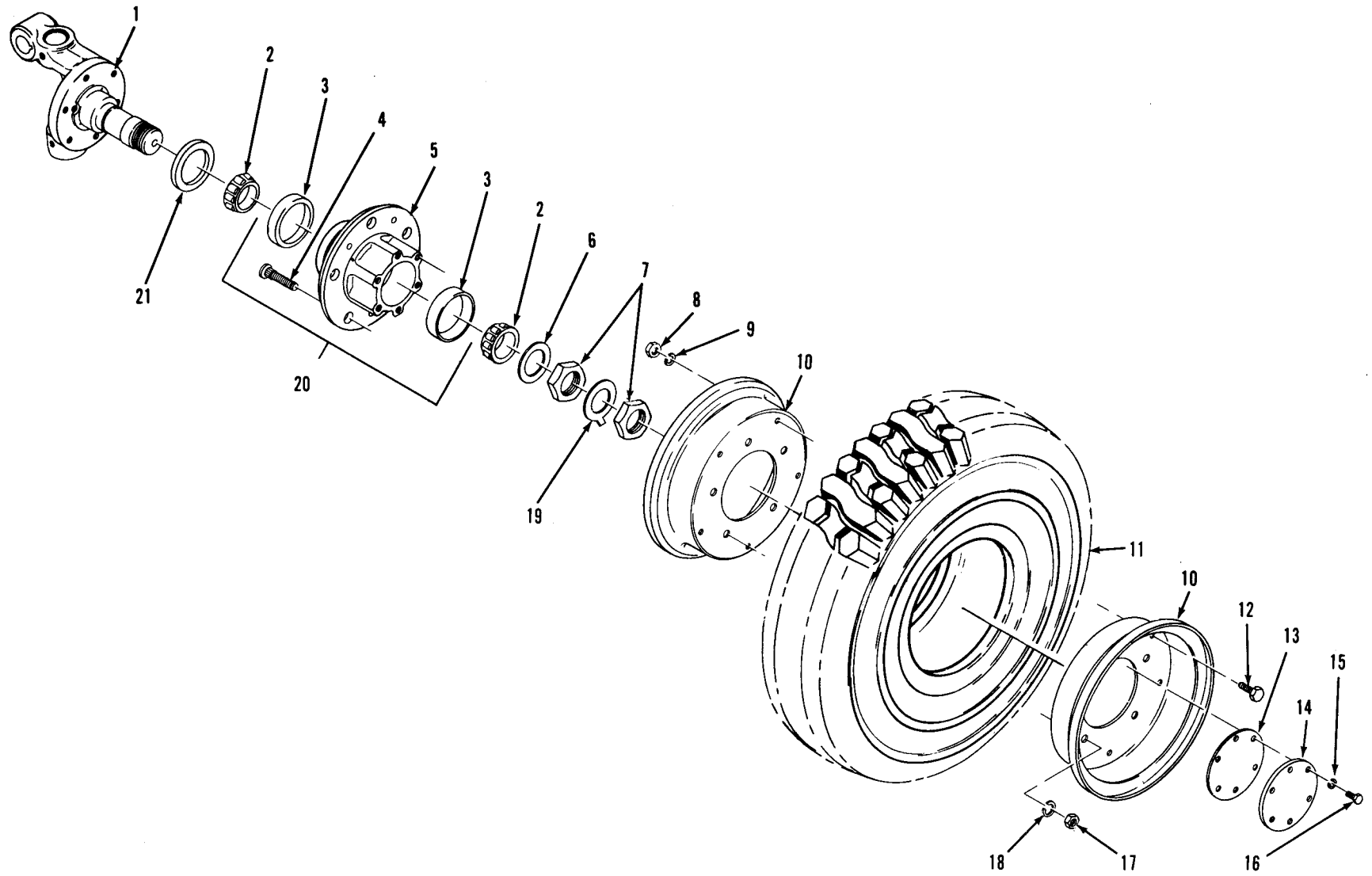

ME 10-3930-626-12/4-40

Figure 4-40. Front wheels, tires, bearings and hubs, exploded view.

KEY to figure 4-40:

1. Spindle
2. Cone
3. cup
4. Bolt
5. Hub
6. Key washer
7. Adjustment nut
8. Nut
9. Washer
10. Wheel
11. Tire
12. Screw
13. Gasket
14. Grease cap
15. Washer
16. Screw
17. Nut
18. Washer
19. Lock
20. Hub assembly
21. Oil seal

*b. Cleaning and Inspection.*

(1) Clean cups, cones, nuts, washers and grease cap with SD, and dry with a clean soft cloth.

(2) Inspect cups, cones, and washers for breaks, cracks, burrs, scoring, and wear. Replace as necessary.

(3) Replace oil seal (21) and lock (19) with new parts.

*c. Installation.* Reverse procedure in *a* above and adjust wheel bearings.

*d. Lubrication.* Lubricate front wheel bearings as required by lubrication order and paragraph 4-9.

*e. Adjustment.* After installing front wheel and before lowering tractor from jack, adjust front wheel bearings as follows:

(1) Remove grease cap (14) and gasket (13).

(2) Bend up sides of lock (19) and remove outer nut (7) and lock. Discard lock.

(3) Tighten inner adjustment nut (7) until a slight drag is felt when the wheel is turned.

(4) Back off nut (7) from one-sixth to one-quarter of a turn. Install new lock (19) and outer nut (7) and bend over tang of lock to secure outer nut in place.

(5) Install grease cap and remove jack and blocks.

**4-61. Front Tires**

*a. Removal.*

(1) Block tractor securely. Using a suitable jack, raise tractor to permit removal of front wheel assemblies.

(2) Remove five wheel mounting nuts (17, fig. 4-40) and washers (18) front bolts (4) and remove wheel and tire assembly.

(3) Deflate tire and remove five nuts (8), washers (9), and screws (12) holding wheel halves together, separate wheel halves and remove flap, tube and tire.

*b. Inspection and Repair.*

(1) Inspect wheels for secure mounting.

(2) Inspect tires for cuts, excessive wear, and imbedded foreign objects.

(3) Repair punctures of tire or tube less than 3/8 inch in greatest dimension by application of a patch on tube and rubber plug in tire casing puncture.

*c. Installation.* Reverse procedure in *a* above.

**4-62. Drive Wheels and Tires**

*a. Removal.*

(1) Block tractor securely. Jack up rear of tractor until drive wheels just clear floor.

(2) Remove wheel nuts (fig. 4-41) and remove dual wheels with assembled tires and tubes.

(3) Fully deflate tires on removed drive wheels.

(4) Remove side ring from wheel using service equipment designed for this purpose. Pull ring free and remove tire and tube.

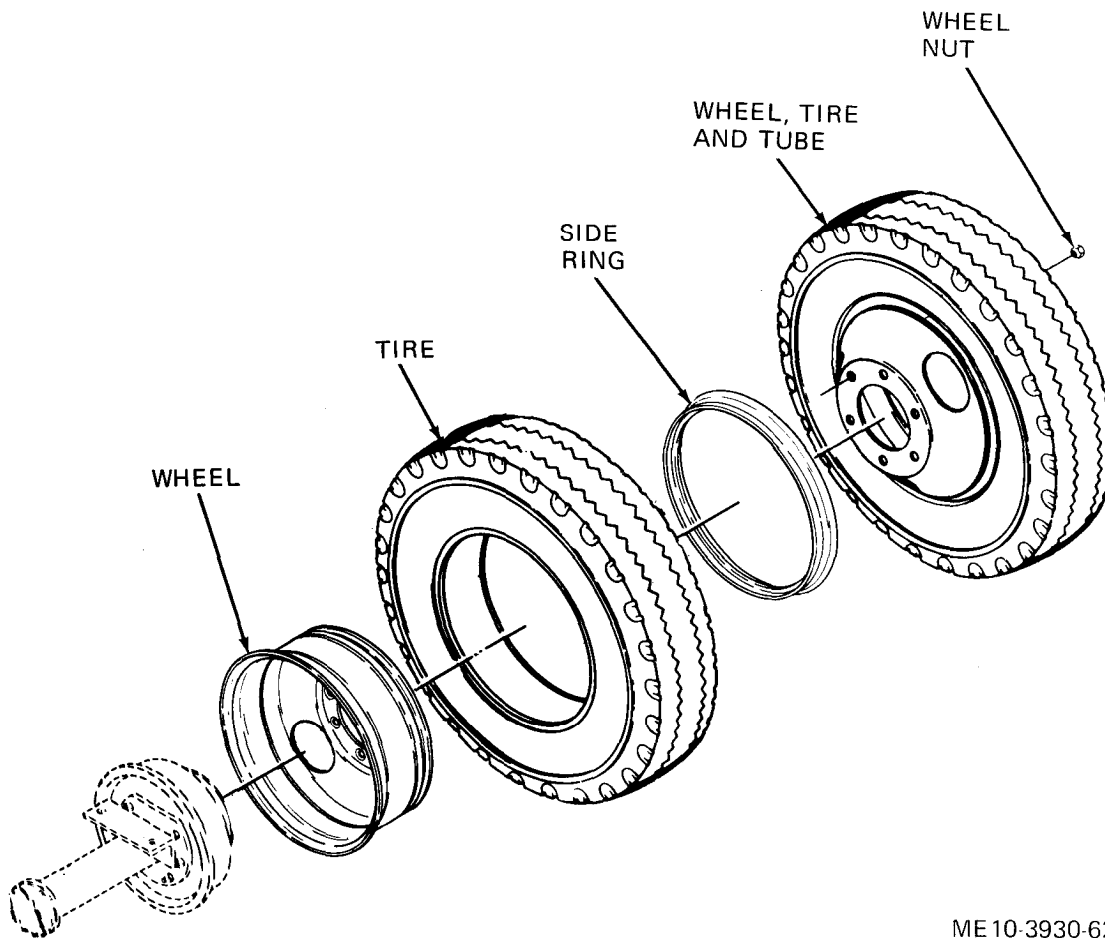

ME10-3930-626-12/4-41

Figure 4-41. Drive wheels and tires, exploded view.

*b. Inspection and Repair.*

- (1) Inspect wheels for secure mounting.
- (2) Inspect tires for cuts, excessive wear and imbedded foreign objects.
- (3) Repair punctures of tire or tube less than 3/8 inch in greatest dimension by application of a patch on tube and rubber plug in tire casing puncture.

*c. Installation.* Reverse procedure in a above. Concave mounting holes in one wheel must mate with convex mounting holes in second wheel.

**4-63. Springs**

*a. General.* Leaf type springs are used to mount the front axle.

*b. Inspection.*

- (1) Inspect springs for broken leaves.
- (2) Inspect attachment of springs to axle to ensure that all attaching parts are tight.
- (3) Inspect attachment of springs to chassis to ensure that all attaching parts are tight.

**Section XVII. STEERING**

**4-64. General**

This section contains instructions for maintenance operations which organizational maintenance personnel are authorized to perform on the steering drag link and steering tie rod.

**4-65. Steering Drag Link**

*a. Removal.*

- (1) ~~Block up vehicle to a suitable working height.~~ *Revised* *see ch 3*
- (2) Remove cotterpins (6, fig. 4-42) securing front adjusting plug (2) and rear adjusting plug (9).
- (3) Back off front and rear adjusting plugs until steering drag link assembly (7) can be removed from ball (11) on steering gear arm and ball on steering knuckle arm (14).

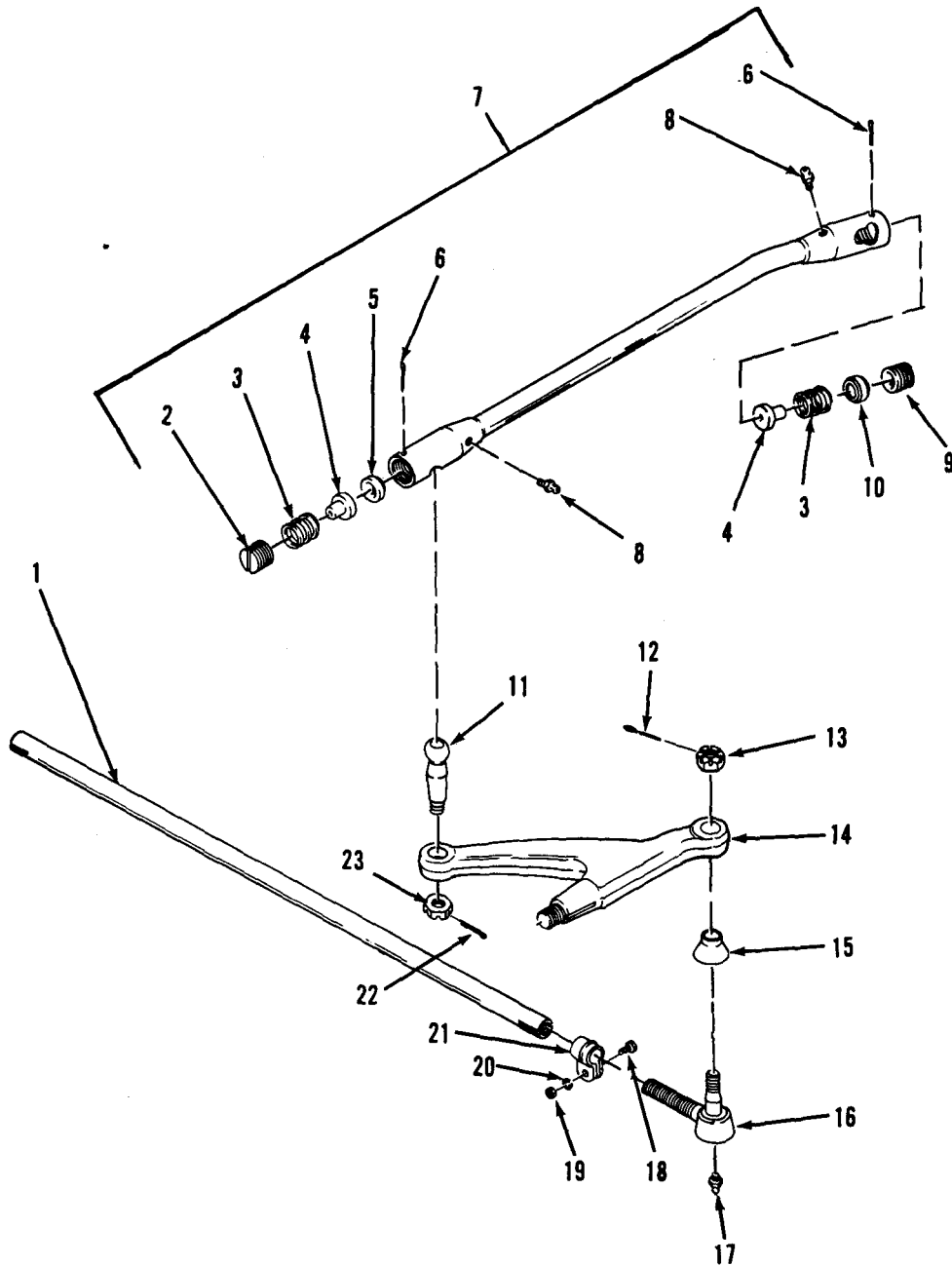

ME 10-3930-626-12/4-42

- |                        |                          |
|------------------------|--------------------------|
| 1. Tie rod             | 13. Slotted nut          |
| 2. Adjusting plug      | 14. Steering knuckle arm |
| 3. Spring              | 15. Boot                 |
| 4. Ball seat           | 16. Tie rod end          |
| 5. Ball seal           | 17. Lubrication fitting  |
| 6. Cotter pin          | 18. Screw                |
| 7. Drag link           | 19. Nut                  |
| 8. Lubrication fitting | 20. Lock washer          |
| 9. Adjusting plug      | 21. Clamp                |
| 10. Spring seat        | 22. Cotter pin           |
| 11. Ball               | 23. Slotted nut          |
| 12. Cotter pin         |                          |

Figure 4-42. Tie rod and drag link, exploded view.

b. *Disassembly.*

- (1) Unscrew front and rear adjusting plugs (2 and 9).
- (2) From steering gear arm end, remove ball seat (4), socket spring (3) and spring seat (10).
- (3) From steering knuckle arm, remove socket spring (3), outer ball seat (4) and inner ball seat (5).
- (4) Unscrew lubrication fittings (8) from steering drag link (7).

c. *Cleaning and Inspection.*

- (1) Clean all parts in SD. Clean passage in lubrication fittings.
- (2) Inspect all parts visually for excessive wear or damage.
- (3) Inspect socket springs (3) for breaks or loss of compression.
- (4) Inspect ball seats (4 and 5) for excessive wear, abrasion or other damage to ball contact surface.
- (5) Inspect adjusting plugs (2 and 9) and ends of drag link for damaged threads.
- (6) Inspect drag link for bends, dents or other damage.

d. *Assembly and Installation.* <sup>Added</sup> Reverse procedure in a and b above. Install cotter pins during adjustment procedure in e below.

e. *Adjustment.* After installing steering drag link, fully tighten adjusting plugs (2 and 9). Back off adjusting plug until slots in adjusting plugs align with cotter pin holes in steering drag link ends. Insert <sup>new</sup> cotter pins (6) to secure adjusting plugs.

*Note.* Excessive tightening of adjusting plug will result in binding in the steering system. Excessively loose adjusting plugs will result in clack or play in the steering system.

#### 4-66. Steering Tie Rod

a. *Removal.*

- (1) ~~Block up vehicle to a suitable working height.~~ <sup>Supported</sup> ~~See ch 3~~
- (2) Remove cotter pins (12, fig. 4-42), securing slotted nuts (13), and remove slotted nuts.

(3) Remove tie rod (1) with tie rod ends (16) attached from holes in left hand and right hand steering knuckle arms (14).

b. *Disassembly.*

(1) Remove boots (15) and lubrication fittings (17) from left hand tie rod end (16) and right hand tie rod end.

(2) Remove nuts (19), washers (20) and screws (18) from clamps (21) and unscrew tie rod ends (16) from tie rod (1).

(3) Slip clamps (21) off tie rod (1).

c. *Cleaning and Inspection.*

(1) Clean all parts in SD. Clear passages of lubrication fittings (17).

(2) Inspect all parts for excessive wear or damage.

(3) Inspect tie rod (1), tie rod ends (16) and mounting hardware for stripped threads.

(4) Inspect tie rod (1) for cracks and deformities.

d. *Assembly and Installation.* <sup>Added</sup> Reverse procedure in a and b above. Be certain to screw each tie rod end (16) into tie rod (1) the same amount of turns. Three or four full turns is sufficient. Leave loop clamps (21) loose until adjustment procedure in e below.

e. *Adjustment.*

(1) With assembled tie rod installed and secured to steering knuckle arms (14) with slotted nuts (13) and cotter pins (12), turn steering hand wheel until wheels are in a straight-ahead position.

(2) Measure span between inside of front tires at front and rear at hub height. Span measured at rear should be one-sixteenth inch to one-eighth inch greater than span measured at front.

(3) Turn tie rod (1) until dimension for toe-in referenced in (2) above is obtained.

(4) Clamp tie rod ends in place by fully tightening loop clamping hardware.

*Note.* Improper toe-in adjustment will result in excessive tire wear.





## CHAPTER 5

# ADMINISTRATIVE STORAGE AND DESTRUCTION OF MATERIEL TO PREVENT ENEMY USE

### Section I. ADMINISTRATIVE STORAGE

#### 5-1. General

Refer to TM 740-90-1 for all information on ad-

ministrative storage applicable to the tractor.

### Section II. DEMOLITION

#### 5-2. General

Do not destroy the tractor except on order of proper authority, and demolish it only to prevent capture and use of the tractor or parts by the enemy. Destroy the same parts on all similar equipment to prevent enemy use through cannibalization.

#### 5-3. Methods

*a. Controls.* Smash all controls, including steering wheel.

*b. Gasoline Engine.* Pierce or smash cylinder block. Damage crankshaft and camshaft.

*c. Transmission, Differential and Gear Case.* Pierce or smash transmission, differential case, and drop gear case.

*d. Steering Gear.* Pierce or smash steering gear housing.

*e. Wires, Cables, and Lines.* Cut, rip out, or otherwise destroy all wires, electrical cables and fuel, oil, or water lines.

*f. Carburetor and Manifolds.* Smash these assemblies.

*g. Generator, Distributor, Ignition Coil, and Spark Plugs.* Destroy these components by smashing.

*h. Radiator.* Drive large holes through core and tank. Break off drain cock.

*i. Battery.* Break case and plates of battery.



APPENDIX A  
REFERENCES

A-1. Fire Protection

**TB 5-4200-200-10** *100*

Hand Portable Fire Extinguishers Approved for Army Users

A-2. Lubrication

C9100IL  
LO 10-3930-626-12

Fuels, Lubricants, Oils and Waxes  
Lubrication Order

A-3. Painting

**TM 9-213** *0139*

Painting Instructions for Field Use

A-4. Radio Suppression

TM 11-483

Radio Interference Suppression

A-5. Maintenance

~~TM 750-651~~ *DAPAM 738-750*  
TM 38-750  
TM 10-3930-626-20P  
**TM 9-6140-200-15**

Use of Antifreeze Solutions and Cleaning Compounds in Engine Cooling Systems  
~~The Army Maintenance Management System~~ *per ch 3*  
~~Organizational Maintenance Repair Parts Manual~~  
~~Operation and Organizational Field and Depot~~  
~~Maintenance Storage Batteries, Lead Acid Type~~

A-6. Shipment and Storage

TB 740-93-2

Preservation of USAMEC Mechanical Equipment for Shipment and Storage

TM 740-90-1

Administrative Storage of Equipment

A-7. Destruction of Army Materiel to Prevent Enemy Use

**TM 750-244-3** *6*

~~Procedures for Destruction of Equipment to Prevent Enemy Use (Mobility Equipment Command)~~



MAINTENANCE ALLOCATION CHART *see ch 3*

## Section I. INTRODUCTION

~~B-1. General~~ *revised*

~~This section provides a general explanation of all maintenance and repair functions authorized at various maintenance levels.~~

~~b. Section II designates overall responsibility for the performance of maintenance functions on the identified end item or component. The implementation of the maintenance functions upon the end item or component will be consistent with the assigned maintenance functions.~~

~~c. Section III is not applicable.~~

~~d. Section IV is not applicable.~~

~~B-2. Explanation of Columns in Section II~~

~~a. *Group Number, Column (1).* The assembly group is a numerical group assigned to each assembly in a top down breakdown sequence. The applicable assembly groups are listed on the MAC in disassembly sequence beginning with the first assembly removed in a top down disassembly sequence.~~

~~b. *Assembly Group, Column (2).* This column contains a brief description of the components of each assembly group.~~

~~c. *Maintenance Functions, Column (3).* This column lists the various maintenance functions (A through K) and indicates the lowest maintenance category authorized to perform these functions. The symbol designations for the various maintenance categories are as follows:~~

- C — Operator or crew
- O — Organizational maintenance
- F — Direct support maintenance
- H — General support maintenance
- D — Depot maintenance

The maintenance functions are defined as follows:

- A—Inspect. To determine serviceability of an item by comparing its physical, mechanical, and electrical characteristics with established standards.
- B—Test. To verify serviceability and to detect electrical or mechanical failure by use of test equipment.
- C—Service. To clean, to preserve, to charge, and to add fuel, lubricants, cooling agents, and air. If it is desired that elements, such as painting and lubricating, be defined separately, they may be so listed.
- D—Adjust. To rectify to the extent necessary to bring into proper operating range.

- E—Align. To adjust specified variable elements of an item to bring to optimum performance.
- F—Calibrate. To determine the corrections to be made in the readings of instruments or test equipment used in precise measurement. Consists of the comparison of two instruments, one of which is a certified standard of known accuracy, to detect and adjust any discrepancy in the accuracy of the instrument being compared with the certified standard.
- G—Install. To set up for use in an operational environment such as an emplacement, site, or vehicle.
- H—Replace. To replace unserviceable items with serviceable like items.
- I—Repair. Those maintenance operations necessary to restore an item to serviceable condition through correction of material damage or a specific failure. Repair may be accomplished at each category of maintenance.
- J—Overhaul. Normally, the highest degree of maintenance performed by the Army in order to minimize time work in process is consistent with quality and economy of operation. It consists of that maintenance necessary to restore an item to completely serviceable condition as prescribed by maintenance standards in technical publications for each item of equipment. Overhaul normally does not return an item to like new, zero mileage, or zero hour condition.
- K—Rebuild. The highest degree of materiel maintenance. It consists of restoring equipment as nearly as possible to new condition in accordance with original manufacturing standards. Rebuild is performed only when required by operational considerations or other paramount factors and then only at the depot maintenance category. Rebuild reduces to zero the hours or miles the equipment, or component thereof, has been in use.

~~d. *Tools and Equipment, Column (4).* This column is provided for referencing by code the special tools and test equipment, (sec. III) required to perform the maintenance functions. (Not applicable).~~

~~e. *Remarks, Column (5).* This column is provided for referencing by code the remarks (sec. IV) pertinent to the maintenance functions. (Not applicable).~~

**Section II. MAINTENANCE ALLOCATION CHART**

(1) Group No.	(2) Functional group	(3) Maintenance functions											Tools and equipment	(5) Remarks				
		A	B	C	D	E	F	G	H	I	J	K						
		Inspect	Test	Service	Adjust	Align	Calibrate	Install	Replace	Repair	Overhaul	Rebuild						
01	<b>ENGINE</b>																	
	Engine Assembly .....	O	O	C	O				F	O	H	D						
	Cylinder Block .....	H								O	D	F						
	Cylinder Head .....								O	H	F	D						
	Crankshaft .....									H	F	D						
	Engine Valves .....				O					F	F	F						
	Timing Gears .....	F								F	F	F						
	Timing Chain .....		F							F	F	F						
	Breather, Oil Filler .....			O						O	O	O						
	Oil Filter .....			O						O	O	O						
	Oil Pump .....	F								F	O	O						
	Manifolds .....	O								O	O	O						
02	<b>FUEL SYSTEM:</b>																	
	Carburetor .....				O					O	F	F						
	Fuel Pump .....			O	O					O	O	O						
	Air Cleaner .....				C					O	O	O						
	Tank, Fuel .....				C					O	H	F						
	Governor .....					C				F	F	F						
	Valve, PCV .....			O						O	O	O						
	Filter, Fuel .....			O						O	O	O						
	Pedal and Linkage, Accelerator .....				O					O	O	O						
03	<b>EXHAUST SYSTEM</b>																	
	Muffler & Pipes .....	O								O	O	O						
04	<b>COOLING SYSTEM</b>																	
	Radiator .....	O	F	C						O	H	H						
	Thermostat .....		O							O	O	O						
	Water Pump .....	O								O	O	O						
	Belt, Fan .....	O			O					O	O	O						
05	<b>ELECTRICAL SYSTEM</b>																	
	Generator .....		O							O	F	F						
	Regulator, Voltage .....		O		O					O	O	O						
	Starting Motor .....		O							O	F	O						
	Distributor .....				O					O	O	O						
	Spark Plugs .....		O	O	O					O	O	O						
	Ignition Coil .....	O								O	O	O						
	Battery .....	O	O	C						O	O	O						
	Cables, Battery .....			O						O	O	O						
06	<b>TRANSMISSION</b>																	
	Filter, Oil .....			F						F	F	F						
	Torque Converter .....			O						F	F	F						
	Gear, Starter Ring .....									F	F	F						
	Transmission Assy .....		F	C						F	F	F		H	D			
	Control Valve .....		F						F	F	F	F						
07	<b>PROPELLER SHAFT</b>																	
	Universal Joints .....			O						O	O	O						
08	<b>REAR AXLE</b>																	
	Rear Axle Assy (Drive) .....			O						F	F	H						
	Differential .....			O						F	F	H						
09	<b>FRONT AXLE</b>																	
	Front Axle Assy (Steering) .....				F			F	F	F	F	F						
10	<b>BRAKES</b>																	
	Hand Brake Shoes .....				O					O	O	O						
	Hand Brake Lever .....				O					O	O	O						
	Hand Brake Cable .....				O					O	O	O						
	Service Brake Shoes .....	O			O					O	O	O		F	F	F		
	Brake Master Cylinder .....	O		O						O	O	O		F	F	F		
	Brake Wheel Cylinders .....	O								O	O	O		F	F	F		
	Service Brake Pedal .....				O					F	F	F						

## Section II. MAINTENANCE ALLOCATION CHART

(1) Group No.	(2) Functional group	(3) Maintenance functions										(4) Tools and equipment	(5) Remarks				
		A	B	C	D	E	F	G	H	I	J			K			
		Inspect	Test	Service	Adjust	Align	Calibrate	Install	Replace	Repair	Overhaul			Rebuild			
11	<b>WHEELS</b>																
	Wheel Assembly .....								O	O							
	Tires and Tubes .....	O		C					O	O							
	Wheel Bearings .....	O		O					O	O							
12	<b>STEERING</b>																
	Drag Link .....			O					O	O							
	Tie Rod .....				O				O	O							
	Steering Gear Assembly .....				F				F	H							
13	<b>FRAME TOWING ATTACHMENT</b>																
	Pintle Assembly .....								O	O							
14	<b>SPRING</b>																
	Springs, Leaf .....	O							F								





APPENDIX C

BASIC ISSUE ITEMS LIST

INDEX

Section I. INTRODUCTION

**C-1. Scope**

This appendix lists items which accompany the warehouse tractor or are required for installation, operation, or operator's maintenance.

**C-2. General**

This Basic Issue Items List is divided into the following sections:

*a. Basic Issue Item8—Section II.* A list of items which accompany the warehouse tractor and are required by the crew / operator for installation, operation, or maintenance.

*b. Maintenance and Operating Supplies—Section III.* A listing of maintenance and operating supplies required for initial operation.

**C-3. Explanation of Columns**

The following provides an explanation of columns in the tabular list of Basic Issue Items, section II.

*a. Source, Maintenance, and Recoverability Codes (SMR):*

(1) Source code, indicates the source for the listed item. Source codes are:

<i>Code</i>	<i>Explanation</i>
P	Repair parts, Special Tools and Test Equipment supplied from the GSA / DSA, or Army supply system and authorized for use at indicated maintenance categories.
P2	Repair parts, Special Tools and Test Equipment which are procured and stocked for insurance purposes because the combat or military essentiality of the end item dictates that a minimum quantity be available in the supply system.
M	Repair parts, Special Tools and Test Equipment which are not procured or stocked, as such, in the Supply System but are to be manufactured at indicated maintenance levels.
A	Assemblies which are not procured or stocked as such, but are made up of two or more units. Such component units carry individual stock numbers and descriptions, are procured and stocked separately and can be assembled to form the required assembly at indicated maintenance categories.
X	Parts and assemblies that are not procured or stocked because the failure rate is normally below that of the applicable end item or component. The failure of such part or assembly should result in retirement of the end item from the supply system.
X1	Repair parts which are not procured or stocked. The requirement for such items will be filled by use of the next higher assembly or component.

<i>Code</i>	<i>Explanation</i>
X 2	Repair parts. Special Tools and Test Equipment which are not stocked and have no foreseen mortality. The indicated maintenance category requiring such repair parts will attempt to obtain the parts through cannibalization or salvage, the item may be requisitioned with exception data, from the end item manager, for immediate use.
G	Major assemblies that are procured with PEMA funds for initial issue only as exchange assemblies at DSU and GSU level. These assemblies will not be stocked above DS and GS level or returned to depot supply level.

(2) Maintenance code, indicates the lowest category of maintenance authorized to install the listed item. The maintenance level code is:

<i>Code</i>	<i>Explanation</i>
C	Crew / Operator

(3) Recoverability code, indicates whether unserviceable items should be returned for recovery or salvage. Items not coded are nonrecoverable. Recoverability codes are:

<i>Code</i>	<i>Explanation</i>
R	Applied to repair parts, (assemblies and components) special tools and test equipment which are considered economically repairable at direct and general support maintenance levels. When the item is no longer economically repairable, it is normally disposed of at the GS level. When supply considerations dictate, some of these repair parts may be listed for automatic return to supply for depot level repair as set forth in AR 710-50. When so listed, they will be replaced by supply on an exchange basis.
S	Repair parts. special tools, test equipment and assemblies which are economically repairable at DSU and GSU activities and which normally are furnished by supply on an exchange basis. When items are determined by a GSU to be uneconomically repairable, they will be evacuated to a depot for evaluation and analysis before final disposition.
T	High dollar value recoverable repair parts, special tools and test equipment which are subject to special handling and are issued on an exchange basis. Such items will be repaired or overhauled at depot maintenance activities only. No repair may be accomplished at lower levels.
U	Repair parts, special tools and test equipment specifically selected for salvage by reclamation units because of precious metal content, critical materials, high dollar value, or reusable casings or castings.

*b. Federal Stock Number.* This column indicates the Federal stock number assigned to the item and will be used for requisitioning purposes.

*c. Description.* This column indicates the Federal item name and any additional description of the item required. The abbreviation "w/e", when used as a part of the nomenclature, indicates the Federal stock number, includes all armament, equipment, accessories, and repair parts issued with the item. A part number or other reference number is followed by the applicable five-digit Federal supply code for manufacturers in parenthesis. Repair parts quantities included in kits, sets, and assemblies are shown in front of the repair part name.

*d. Unit of Measure (U/M).* A two character alphabetic abbreviation indicating the amount or quantity of the item upon which the allowances are based, e.g., ft, ea, pr, etc.

*e. Quantity Incorporated in Unit.* This column indicates the quantity of the item used in the assembly group. A "V" appearing in this column in lieu of a quantity indicates that a definite quantity cannot be indicated (e.g. shims, spacers, etc.)

*f. Quantity Furnished With Equipment.* This column indicates the quantity of an item furnished with the equipment.

*g. Illustration.* This column is divided as follows:

(1) *Figure number.* Indicates the figure number of the illustration in which the item is shown.

(2) *Item number.* Indicates the callout number used to reference the item in the illustration.

#### **4. Explanation of Columns in the Tabular List of Maintenance and Operating Supplies-Section III**

*a. Component Application.* This column identifies the component application of each maintenance or operating supply item.

*b. Federal Stock Number.* This column indicates the Federal stock number assigned to the item and will be used for requisitioning purposes.

*c. Description.* This column indicates the item name and brief description.

*d. Quantity Required for Initial Operation.* This column indicates the quantity of each maintenance or operating supply item required for initial Operation of the equipment.

*e. Quantity Required for 8 Hours Operation.* This column indicates the estimated quantities required for an average 8 hours of operation.

*f. Notes.* This column indicates informative notes keyed to data appearing in a preceding column.



## Section III. MAINTENANCE AND OPERATING SUPPLIES

(1) Component application	(2) Federal stock number	(3) Description	(4) Quantity required F initial operation	(5) Quantity required F/ 8 hrs operation	(6) Notes
CRANKCASE (1)	.....	OIL, LUBRICATING:			(1) Includes quantity of oil to fill engine oil systems as follows:
	9150-231-6653	5 gal. Drum as follows:			
	9150-265-9435	Grade 9250	6qt		5 qt—Crankcase
	9150-231-9037	OE-30 .....	6 qt		1qt—Oil Filter
	9150-265-9428	Grade 9110	6 qt		
	9150-242-7603	OE-10 .....	6 qt		
TRANSMISSION (2)	.....	OES .....	8qt		(2) Use oil as prescribed in item 1.
&	.....	OE-10 .....			
CONVERTER	.....	OES .....			
HYDRAULIC BRAKE	.....	OIL, HYDRAULIC			
SYSTEM	.....	1 gal. Can as follows:			(3) Represents quantity of oil to fill reservoir to proper level.
	9150-231-9071	HB-Nonpetroleum Base, Automotive	1 pt—(3)		
	9150-252-6375	HBA-Nonpetroleum Base Automotive Arctic-Type		6 gal.	
FUEL TANK .....	9130-264-6218	GASOLINE, AUTOMOTIVE	13 gal (4)		(4) Tank Capacity
	.....	Bulk.	14½ qt		
RADIATOR .....	.....	WATER			
	6850-243-1992	ANTIFREEZE: Inhibited glycol, 1 gal. can			
	6850-174-1806	ANTIFREEZE: Compound Arctic, 55 gal. drum			
DIFFERENTIAL .....	.....	OIL, LUBRICATING, GEAR:			
	9150-577-5844	5 gal. Pail as follows:			
	9150-257-5440	GO-90	9½ pt		
	9150-577-5844	GOS			
DROP GEAR CASE	9150-577-5844	GO-90	1½ pt		
	9150-257-5440	GOS			
STORAGE	.....	ACID, Sulfuric, electrolite, dilute specific gravity			
BATTERY, 12 V	6810-249-9354	1.250.	5 qt		

I N D E X

	Paragraph	Page
Accelerator (and linkage), removal, installation, and adjustment . . . . .	4-40	4-24
Accelerator pedal, location and use of . . . . .	2-8	2-4
Air cleaner, operator's service . . . . .	3-12	3-6
Air cleaner, removal and installation . . . . .	4-34	4-17
Ammeter, location and purpose of . . . . .	2-9	2-4
Axle, drive, description of . . . . .	1-6	
Basic issue items . . . . .	3-1	
Battery, adding water . . . . .	3-1	
Battery, characteristics of . . . . .	1-7	
Battery, cleaning terminals . . . . .	3-15	3-8
Battery, operator's service . . . . .	3-15	3-7
Battery, recharging . . . . .	3-15	3-8
Battery, removal, cleaning, installation, and testing . . . . .	4-51	4-40
Battery, service upon receipt . . . . .	2-3	2-1
Battery, specific gravity of electrolyte . . . . .	3-15	3-8
Bearings, front wheel, lubrication of . . . . .	4-9	4-1
Bearings, front wheel, removal, cleaning, inspecting, installing and adjusting . . . . .	4-60	4-48
Belt, fan (see fan belt) . . . . .		
Brake pedal, use and location of . . . . .	2-8	2-4
Brake system, bleeding . . . . .	4-57	4-48
Brake, hand, service upon receipt . . . . .	2-3	2-1
Brake, parking, description of . . . . .	1-6	
Brakes, pedal adjustment . . . . .	4-58	4-48
Brakes, service, adjustment . . . . .	4-56	4-46
Brakes, service, description of . . . . .	1-6	
Brakes, service, repair of . . . . .	4-56	4-46
Brakes, service, service upon receipt . . . . .	2-3	2-1
Cables, battery, cleaning, removal, and installation . . . . .	4-51	4-40
Cables, battery, operators maintenance of carburetor, adjustment, removal, and installation . . . . .	4-36	4-17
Carburetor, characteristics of . . . . .	1-7	
Choke control, location and use of . . . . .	2-8	2-4
Choke control, removal, installation, and adjustment . . . . .	4-40	4-24
Coil, ignition, testing, removal and installation . . . . .	4-50	4-40
Controls, description and location of . . . . .	2-8	2-4
Cooling system, capacity of . . . . .	1-7	
Cooling system, service upon receipt . . . . .	2-3	2-1
Crankcase, capacity of . . . . .	1-7	
Crankcase, service by operator . . . . .	3-3	
Crankcase, service upon receipt . . . . .	2-3	2-1
<del>Cylinder head removal, cleaning, inspection and installation . . . . .</del>	<del>4-25</del>	<del>4-10</del>
Cylinders, brake, removal, inspection and installation . . . . .	4-56	4-46
Cylinder, master (see master cylinder) . . . . .		
Description of tractor . . . . .	1-6	
Differential, capacity of . . . . .	1-7	
Dimensions of tractor . . . . .	1-7	
Distributor, removal, inspection, repair and installation . . . . .	4-49	4-38
Drag link, removal, disassembly, cleaning, inspection, assembly, installation and adjustment . . . . .	4-65	4-51
Drive axle, characteristics of . . . . .	1-7	
Drive axle, description of . . . . .	1-6	
Drive train, description . . . . .	1-6	
Driving instructions, normal . . . . .	2-12	2-5
Drop gearcase, capacity of . . . . .	1-7	
Drop gearcase, description of . . . . .	1-6	
Drop gearcase, service upon receipt of . . . . .	2-3	
Electrical system, description of . . . . .	1-6	
Engine temperature gage, location and purpose of . . . . .	2-9	2-4
Engine, characteristics of . . . . .	1-7	
Engine, compression test . . . . .	4-22	4-6
Engine, description of . . . . .	4-21	4-6
Engine, manifold vacuum test . . . . .	4-24	4-8

*See  
Ch 3*

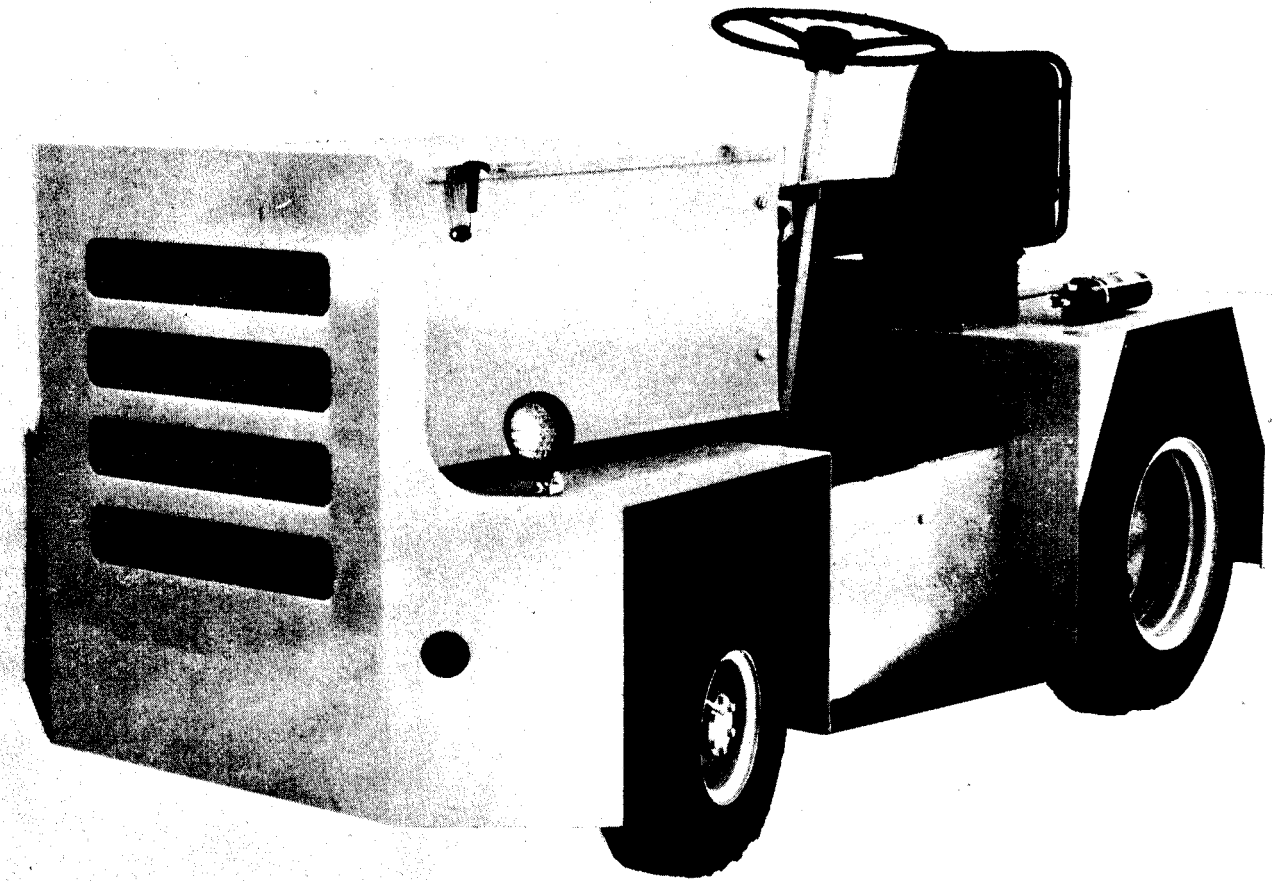

ME10-3930-626-12/1-1

*Figure 1-1. Tractor, three-quarter front view.*

(added)

See ch 3  
pg 13

	Paragraph	Page
Positive crankcase ventilation, servicing of system . . . . .	4-20	4-6
Preventive maintenance, operator's, general information . . . . .	3-4	3-3
Preventive maintenance, organizational, purpose of . . . . .	4-12	4-2
Preservatives, removal of . . . . .	2-3	2-1
Propeller shaft, removal of universal joints . . . . .	4-53	4-42
Quarterly interval, definition of . . . . .	4-13	4-2
Radiator, adding coolant . . . . .	3-11	3-4
Radiator, cleaning and refilling. . . . .	3-3	3-2
Radiator, external cleaning . . . . .	3-11	3-4
Radiator, inspection, removal, and installation . . . . .	4-33	4-17
Radiator, operator's preventive maintenance . . . . .	3-11	3-4
Radiator hoses, (see hoses, radiator) . . . . .		
Radio interference suppression, location and replacement of components . . . . .	4-17	4-4
Radio interference suppression, methods of . . . . .	4-16	4-4
Radio interference suppression, testing components . . . . .	4-18	4-5
Rear light switch, description and location of . . . . .	2-8	2-4
Records . . . . .	1-2	1-1
Regulator, generator, testing, adjusting, removal, and installation . . . . .	4-48	4-38
Repair parts . . . . .	4-5	4-1
Reporting errors . . . . .	1-3	1-1
Right hand, definition of . . . . .	1-5	1-3
Seat, installing upon receipt . . . . .	2-4	2-1
Seat adjuster lever, location and use of . . . . .	2-8	2-4
Service brakes, adjustment . . . . .	4-56	4-46
Service brakes, repair . . . . .	4-56	4-46
Servicing upon receipt, procedures for . . . . .	2-3	2-1
Service upon receipt, responsibilities for . . . . .	2-2	2-1
Service upon receipt of tractor, organizational maintenance responsibilities . . . . .	4-1	4-1
Shift lever, transmission, location and use of . . . . .	2-8	2-4
Spark plugs . . . . .	1-7	
Spark plugs, removal, inspection, cleaning, testing, adjustment, replacement, and installation . . . . .	4-29	4-14
Special tools and equipment. . . . .	4-4	4-1
Springs, front, inspection . . . . .	4-63	4-51
Starter switch, description and location of . . . . .	2-8	2-4
Starting instructions, normal . . . . .	2-11	2-5
Starting motor, testing, removal, and installation . . . . .	4-48	4-38
Steering gear, capacity of . . . . .	1-7	
Steering gear, characteristics of . . . . .	1-7	
Steering, description of . . . . .	1-6	
Steering handwheel, use of . . . . .	2-8	2-4
Stopping instructions . . . . .	2-13	2-6
Tabulated data . . . . .	1-7	
Temperature gage, engine, location and purpose of . . . . .	2-9	2-4
Thermostat, removal, testing, and installation . . . . .	4-32	4-15
Tie rod, removal, disassembly cleaning, inspection, assembly, installation, and adjustment . . . . .	4-65	4-51
Tires, drive (rear) removal, inspection, repair, and installation . . . . .	4-62	4-50
Tires, front, removal, inspection, repair, and installation . . . . .	4-61	4-50
Tires, inflation pressures . . . . .	1-7	
Tires, service on receipt . . . . .	2-3	2-1
Tires, size and type . . . . .	1-7	
Tires and tubes, operator's service . . . . .	3-14	3-7
Tools and equipment . . . . .	4-3	4-1
Towing capacity . . . . .	1-7	
Torque converter (and transmission), service by operator. . . . .	3-3	3-2
Torque convertor service upon receipt . . . . .	2-3	2-1
Torque converter temperature gage, location and purpose of . . . . .	2-9	2-5
Torquing, values for threaded parts . . . . .	1-7	
Transmission, characteristics of . . . . .	1-7	
Transmission, service by operator . . . . .	3-3	3-2
Transmission, service upon receipt . . . . .	2-3	2-1
Troubleshooting, operator's . . . . .	3-7	3-3
Troubleshooting, organizational maintenance . . . . .	4-15	4-3
Universal joints, removal and installation . . . . .	4-53	4-42
Valves, adjustment . . . . .	4-26	4-11

*See vol 3  
0913  
(added)*

	Paragraph	Page
Valves, lash . . . . .	1-7	
Valve cover, removal and installation . . . . .	4-26	4-11
Water pump, removal, inspection, and installation . . . . .	4-28	4-13
Wheels, drive (rear), removal, inspection, and installation. . . . .	4-62	4-50
Wheels, front, removal and installation . . . . .	4-60	4-48
Weight of tractor . . . . .	1-7	



By Order of the Secretary of the Army:

W. C. WESTMORELAND,  
*General, United States Army,*  
*Chief of Staff.*

Official:

VERNE L. BOWERS,  
*Major General, United States Army,*  
*The Adjutant General.*

To be distributed in accordance with DA Form 12-25, Section I, (qty rqr block  
no. 285) Operator maintenance requirements for Warehouse Tractors.

*tr* U.S. GOVERNMENT PRINTING OFFICE: 1971-431-107/822





**TM 10-3930-626-12 TRACTOR, WHEELED, WAREHOUSE GASOLINE, 4,000 LB - 1971**